

# WASTEWATER SYSTEM OPERATOR'S MANUAL



**Ragsdale and Associates Training Specialists, LLC**

**804 Omaha NE**

**Albuquerque, NM 87123**

[www.ragsdaleandassociates.com](http://www.ragsdaleandassociates.com)

[Fredragsdale@comcast.net](mailto:Fredragsdale@comcast.net)

# WASTEWATER SYSTEM OPERATOR'S MANUAL

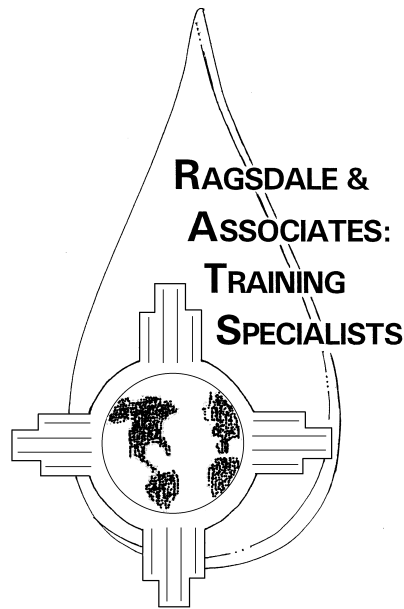

Prepared By

Fred Ragsdale

Ragsdale and Associates Training Specialists, LLC

Dedicated to my mentors:

Dempsey Hall  
Richard Harrison  
Harold Fox  
Steve Amos  
Teddy Watts  
Pete Orr  
Herb Filer  
Dorsett Wilson  
Jerry McCreary

## **INTRODUCTION**

This "WASTEWATER SYSTEM OPERATOR'S MANUAL" has been created as a tool to assist wastewater systems operators in understanding the basics of how to operate and maintain a wastewater collection and treatment systems. This book is not intended to be a complete reference manual for wastewater systems technical information. It is intended to be comprehensive in its coverage of the Need-To-Know criteria for wastewater collection and treatment systems operations and maintenance as identified by the Association of Boards of Certification (ABC), Arizona Department of Environmental Quality (ADEQ), and New Mexico Environment Department (NMED). Our belief is that if you understand how a wastewater system is operated and maintained, you will be able to pass a Wastewater Operator certification exam.

This manual is divided into seventeen chapters. Each chapter has basic and advanced study questions and sample test questions that are intended help the individual focus on the type of information that may be covered in an operator certification exam. Basic questions will cover information in the Grade 1 and 2 Wastewater Collection Systems and Wastewater Treatment Systems exams. Advanced questions will generally cover information in the Grade 3 and 4 Wastewater Collection Systems and Wastewater Treatment Systems exams. The study questions are designed to direct the reader to information that is related to the Need-To-Know criteria. No answer sheet is provided. You will have to look them up.

This material has been referenced in Sacramento State, Texas A&M Extension Service, State of New York, WPCF, and NMED publications.



# WASTEWATER SYSTEM OPERATOR'S MANUAL

## TABLE OF CONTENTS

### CHAPTER 1: INTRODUCTION TO WASTEWATER TREATMENT

BOD AND SUSPENDED SOLIDS	1-1
INDUSTRIAL WASTEWATER	1-2
COLIFORM GROUP OF BACTERIA	1-3
OVERVIEW OF WASTEWATER TREATMENT PROCESSES	1-3
NPDES REGULATIONS	1-3
WASTEWATER TREATMENT BACTERIA	1-4
pH AND WASTEWATER	1-5
EFFECTS OF TEMPERATURE AND pH ON BIOLOGICAL ACTIVITY	1-6
DAILY FLOW FLUCTUATIONS	1-6
THE CARBON CYCLE	1-7
THE NITROGEN CYCLE	1-8
STUDY QUESTIONS	1-9

### CHAPTER 2: PLANT PRETREATMENT

BAR SCREENS	2-1
COMMINUTORS AND GRINDER PUMPS	2-3
BARMINUTORS	2-4
GRIT CHAMBERS	2-4
FLOW MEASUREMENT	2-6
OPEN CHANNEL WEIRS	2-6
MEASURING FLOWS IN OPEN CHANNELS	2-7
PARSCHALL FLUMES	2-7
FLOW EQUALIZATION BASINS	2-8
STUDY QUESTIONS	2-9

### CHAPTER 3: PRIMARY TREATMENT

PRIMARY CLARIFIERS	3-1
INFLUENT ZONE	3-1
SETTLING ZONE	3-2
SKIMMING ZONE	3-2
EFFLUENT ZONE	3-3
PRIMARY SLUDGE PUMPING	3-4
SECONDARY CLARIFIERS	3-4
STUDY QUESTIONS	3-5

## **CHAPTER 4: SOLIDS HANDLING**

<b>GRAVITY THICKENERS</b>	<b>4-1</b>
<b>DISSOLVED AIR FLOTATION</b>	<b>4-2</b>
<b>OTHER SLUDGE THICKENING PROCESSES</b>	<b>4-4</b>
<b>STUDY QUESTIONS</b>	<b>4-7</b>

## **CHAPTER 5: DIGESTION**

<b>ANAEROBIC DIGESTION</b>	<b>5-1</b>
<b>TEMPERATURE RANGES FOR ANAEROBIC DIGESTION</b>	<b>5-2</b>
<b>ANAEROBIC DIGESTERS</b>	<b>5-2</b>
<b>GAS HANDLING SYSTEMS</b>	<b>5-4</b>
<b>SLUDGE FEED AND REMOVAL</b>	<b>5-5</b>
<b>DIGESTER UPSETS</b>	<b>5-6</b>
<b>AEROBIC DIGESTERS</b>	<b>5-6</b>
<b>SLUDGE DRYING BEDS</b>	<b>5-6</b>
<b>STUDY QUESTIONS</b>	<b>5-7</b>

## **CHAPTER 6: LAGOONS AND STABILIZATION PONDS**

<b>TYPES OF LAGOONS</b>	<b>6-1</b>
<b>LAGOON SYSTEM DESIGN</b>	<b>6-3</b>
<b>CHANGING THE WATER LEVEL</b>	<b>6-4</b>
<b>BIOLOGY AND CHEMISTRY OF LAGOONS</b>	<b>6-5</b>
<b>LOADING AND DETENTION TIMES</b>	<b>6-6</b>
<b>LAGOON SYSTEM MAINTENANCE</b>	<b>6-6</b>
<b>ODOR CONTROL</b>	<b>6-6</b>
<b>OBSERVATIONS AND OPERATIONAL TESTING</b>	<b>6-7</b>
<b>STUDY QUESTIONS</b>	<b>6-8</b>

## **CHAPTER 7: SECONDARY TREATMENT - FIXED MEDIA PROCESSES**

<b>TRICKLING FILTERS</b>	<b>7-1</b>
<b>ZOOGLIAL FILM</b>	<b>7-2</b>
<b>TRICKLING FILTER OPERATIONS</b>	<b>7-2</b>
<b>ROTATING BIOLOGICAL CONTACTORS (RBC'S)</b>	<b>7-3</b>
<b>STUDY QUESTIONS</b>	<b>7-6</b>

## **CHAPTER 8: SECONDARY TREATMENT - ACTIVATED SLUDGE**

<b>ACTIVATED SLUDGE TERMINOLOGY</b>	<b>8-1</b>
<b>ACTIVATED SLUDGE PROCESSES</b>	<b>8-2</b>
<b>CONVENTIONAL ACTIVATED SLUDGE PROCESSES</b>	<b>8-2</b>
<b>CONTACT STABILIZATION PROCESSES</b>	<b>8-2</b>
<b>EXTENDED AERATION PROCESSES</b>	<b>8-4</b>
<b>OXIDATION DITCHES</b>	<b>8-4</b>
<b>SEQUENCED BATCH REACTORS (SBR)</b>	<b>8-5</b>
<b>BIOLOGICAL GROWTH RATE</b>	<b>8-6</b>
<b>INFLUENT FLOW PATTERNS</b>	<b>8-6</b>
<b>PROCESS CONTROL</b>	<b>8-7</b>
<b>ACTIVATED SLUDGE MICROORGANISMS</b>	<b>8-8</b>
<b>SLUDGE PROBLEMS</b>	<b>8-9</b>
<b>AERATION TANK FOAM</b>	<b>8-10</b>
<b>STUDY QUESTIONS</b>	<b>8-11</b>

## **CHAPTER 9: TERTIARY TREATMENT**

<b>EFFLUENT POLISHING</b>	<b>9-1</b>
<b>RAPID SAND FILTERS</b>	<b>9-1</b>
<b>EFFLUENT POLISHING PONDS</b>	<b>9-4</b>
<b>NUTRIENT REMOVAL</b>	<b>9-4</b>
<b>NITRIFICATION</b>	<b>9-5</b>
<b>DENITRIFICATION</b>	<b>9-5</b>
<b>OXIDATION REDUCTION POTENTIAL</b>	<b>9-8</b>
<b>OTHER NITROGEN REMOVAL PROCESSES</b>	<b>9-8</b>
<b>PHOSPHOROUS REMOVAL</b>	<b>9-9</b>
<b>STUDY QUESTIONS</b>	<b>9-9</b>

## **CHAPTER 10: WASTEWATER DISINFECTION**

<b>CHLORINE GAS</b>	<b>10-1</b>
<b>CHLORINE POWDER</b>	<b>10-1</b>
<b>CHLORINE BLEACH</b>	<b>10-1</b>
<b>CHLORINE TREATMENT TERMS</b>	<b>10-2</b>
<b>FREE CHLORINE RESIDUAL</b>	<b>10-3</b>
<b>COMBINED CHLORINE RESIDUAL</b>	<b>10-3</b>
<b>DISINFECTION REQUIREMENTS</b>	<b>10-3</b>
<b>EFFECTS OF TEMPERATURE AND PH</b>	<b>10-3</b>
<b>BREAKPOINT CHLORINATION</b>	<b>10-4</b>
<b>TESTING FOR CHLORINE RESIDUALS</b>	<b>10-5</b>
<b>GENERAL CHLORINE SAFETY</b>	<b>10-5</b>
<b>CHLORINATOR ROOM</b>	<b>10-6</b>
<b>CHLORINE STORAGE</b>	<b>10-6</b>
<b>CHLORINE CYLINDERS</b>	<b>10-6</b>
<b>HTH AND BLEACH HANDLING SAFETY</b>	<b>10-7</b>

## **CHAPTER 10: WASTEWATER DISINFECTION (CONT.)**

<b>RESPIRATORY PROTECTION</b>	<b>10-7</b>
<b>GAS MASKS</b>	<b>10-8</b>
<b>SCBA</b>	<b>10-8</b>
<b>CHLORINATION EQUIPMENT</b>	<b>10-8</b>
<b>GAS CHLORINATION</b>	<b>10-8</b>
<b>HYPOCHLORINATION SYSTEMS</b>	<b>10-12</b>
<b>EMERGENCY RESPONSE PROCEDURES</b>	<b>10-13</b>
<b>ALTERNATIVES TO CHLORINATION</b>	<b>10-14</b>
<b>OZONE</b>	<b>10-14</b>
<b>ULTRA-VIOLET RADIATION</b>	<b>10-14</b>
<b>STUDY QUESTIONS</b>	<b>10-15</b>

## **CHAPTER 11: DECHLORINATION**

<b>SULPHUR DIOXIDE</b>	<b>11-1</b>
<b>ALTERNATIVES</b>	<b>11-1</b>
<b>STUDY QUESTIONS</b>	<b>11-2</b>

## **CHAPTER 12: SAMPLING AND LABORATORY**

<b>GRAB SAMPLES</b>	<b>12-1</b>
<b>COMPOSITE SAMPLES</b>	<b>12-1</b>
<b>PROPORTIONAL COMPOSITE SAMPLES</b>	<b>12-1</b>
<b>WASTEWATER LABORATORY</b>	<b>12-2</b>
<b>GENERAL LABORATORY SAFETY</b>	<b>12-2</b>
<b>SETTLEOMETER TEST</b>	<b>12-2</b>
<b>TESTING METERS</b>	<b>12-3</b>
<b>BACTERIOLOGICAL TESTING</b>	<b>12-4</b>
<b>MIXED LIQUOR SUSPENDED SOLIDS TESTING</b>	<b>12-4</b>
<b>BOD/COD TESTING</b>	<b>12-5</b>
<b>STUDY QUESTIONS</b>	<b>12-6</b>

## **CHAPTER 13: COLLECTION SYSTEMS**

<b>OVERVIEW</b>	<b>13-1</b>
<b>WASTEWATER PIPING</b>	<b>13-3</b>
<b>MANHOLES AND CLEANOUTS</b>	<b>13-4</b>
<b>INVERTED SIPHON</b>	<b>13-6</b>
<b>SERVICES</b>	<b>13-6</b>
<b>COLLECTION SYSTEM CONSTRUCTION</b>	<b>13-7</b>
<b>HANDLING PIPE</b>	<b>13-7</b>
<b>EXCAVATIONS AND UTILITY LOCATION</b>	<b>13-8</b>
<b>PIPING GRADES</b>	<b>13-9</b>
<b>BEDDING PIPING</b>	<b>13-10</b>
<b>BACKFILL CONSIDERATIONS</b>	<b>13-11</b>
<b>TESTING AND INSPECTING SEWER LINES</b>	<b>13-12</b>

## **CHAPTER 13: COLLECTION SYSTEMS (CONT)**

<b>TESTING SEWER LINES</b>	<b>13-13</b>
<b>DYE TESTING</b>	<b>13-13</b>
<b>PRESSURE TESTING</b>	<b>13-13</b>
<b>SMOKE TESTING</b>	<b>13-14</b>
<b>CCTV INSPECTION</b>	<b>13-15</b>
<b>PROBLEMS IDENTIFIED BY CCTV INSPECTION</b>	<b>13-15</b>
<b>STRUCTURAL PROBLEMS</b>	<b>13-15</b>
<b>ROOTS, GREASE AND CORROSION</b>	<b>13-16</b>
<b>BALLS AND KITES AND SCOOTERS</b>	<b>13-18</b>
<b>JET CLEANERS</b>	<b>13-18</b>
<b>RODDING MACHINES</b>	<b>13-21</b>
<b>BUCKET MACHINES</b>	<b>13-22</b>
<b>LIFT STATIONS</b>	<b>13-23</b>
<b>LIFT STATION PUMPS</b>	<b>13-24</b>
<b>PIPING REPAIRS AND REHABILITATION</b>	<b>13-26</b>
<b>PIPING REPAIRS</b>	<b>13-26</b>
<b>CHEMICAL GROUTING</b>	<b>13-27</b>
<b>LINE REHABILITATION</b>	<b>13-28</b>
<b>SLIP LINING</b>	<b>13-28</b>
<b>PIPE BURSTING</b>	<b>13-29</b>
<b>CURED-IN-PLACE PIPELINING (CIPP)</b>	<b>13-31</b>
<b>STUDY QUESTIONS</b>	<b>13-31</b>

## **CHAPTER 14: PUMPS AND MOTORS**

<b>CENTRIFUGAL PUMPS</b>	<b>14-2</b>
<b>TYPES OF CENTRIFUGAL PUMPS</b>	<b>14-3</b>
<b>CENTRIFUGAL PUMP COMPONENTS</b>	<b>14-6</b>
<b>PUMP HYDRAULICS</b>	<b>14-12</b>
<b>PUMP CHARACTERISTIC CURVES</b>	<b>14-14</b>
<b>SHUTOFF HEAD</b>	<b>14-15</b>
<b>CHECKING SHUTOFF HEAD</b>	<b>14-16</b>
<b>NET POSITIVE SUCTION HEAD</b>	<b>14-16</b>
<b>COMMON OPERATIONAL PROBLEMS</b>	<b>14-17</b>
<b>CAVITATION</b>	<b>14-17</b>
<b>AIR LOCKING</b>	<b>14-18</b>
<b>LOSS OF PRIME</b>	<b>14-18</b>
<b>CENTRIFUGAL BLOWERS</b>	<b>14-18</b>
<b>STUDY QUESTIONS</b>	<b>14-19</b>

## **CHAPTER 15: MECHANICAL SYSTEMS O & M**

<b>PUMP MAINTENANCE</b>	<b>15-1</b>
<b>PUMP PACKING</b>	<b>15-1</b>
<b>REMOVING OLD PACKING</b>	<b>15-2</b>
<b>REPACKING THE PUMP</b>	<b>15-3</b>
<b>ADJUSTING THE PACKING GLAND</b>	<b>15-4</b>
<b>BEARING MAINTENANCE</b>	<b>15-5</b>
<b>COUPLINGS</b>	<b>15-5</b>
<b>MOTOR ALIGNMENT</b>	<b>15-6</b>
<b>ELECTRIC MOTORS</b>	<b>15-7</b>
<b>PHASES</b>	<b>15-7</b>
<b>SINGE PHASE MOTORS</b>	<b>15-7</b>
<b>THREE PHASE MOTORS</b>	<b>15-7</b>
<b>SINGLE PHASING</b>	<b>15-8</b>
<b>CIRCUIT PROTECTION</b>	<b>15-8</b>
<b>CHEMICAL FEED SYSTEMS</b>	<b>15-8</b>
<b>PROCESS INSTRUMENTATION</b>	<b>15-10</b>
<b>INSTRUMENTATION LOOPS</b>	<b>15-12</b>
<b>STUDY QUESTIONS</b>	<b>15-13</b>

## **CHAPTER 16: SAFETY**

<b>LOCK OUT/TAG OUT (LOTO)</b>	<b>16-1</b>
<b>CONFINED ENERGY SPACE</b>	<b>16-2</b>
<b>HAZARD COMMUNICATION</b>	<b>16-2</b>
<b>NFPA COLOR CODE WARNING SYSTEM</b>	<b>16-4</b>
<b>FIRE EXTINGUISHER SAFETY</b>	<b>16-5</b>
<b>EXCAVATION SAFETY</b>	<b>16-5</b>
<b>STUDY QUESTIONS</b>	<b>16-7</b>

## **CHAPTER 17: MATHEMATICS FOR WATER OPERATORS**

<b>FLOWS</b>	<b>17-1</b>
<b>AREAS</b>	<b>17-1</b>
<b>VOLUMES</b>	<b>17-2</b>
<b>VOLUMES IN GALLONS</b>	<b>17-2</b>
<b>DETENTION TIME</b>	<b>17-3</b>
<b>DOSAGE</b>	<b>17-4</b>
<b>PROCESS REMOVAL EFFICIENCY</b>	<b>17-5</b>
<b>PROCESS LOADING CALCULATIONS</b>	<b>17-5</b>
<b>F:M RATIO</b>	<b>17-6</b>
<b>SLUDGE VOLUME INDEX (SVI)</b>	<b>17-7</b>
<b>MEAN CELL RESIDENCE TIME (MCRT) OR SLUDGE AGE</b>	<b>17-7</b>
<b>WIRE-TO-WATER CALCULATIONS</b>	<b>17-8</b>
<b>STUDY QUESTIONS</b>	<b>17-11</b>

## INTRODUCTION TO WASTEWATER TREATMENT

The term wastewater is commonly used to describe liquid wastes that are collected and transported to a treatment facility through a system of sewers. Wastewater is generally divided into two broad classifications: domestic wastewater and industrial wastewater. Domestic wastewater comes from communities of homes, businesses, and institutions. Domestic wastewater is 99.9% water and only 0.1% solids. Milligrams per liter (mg/L) is the metric equivalent of parts per million (one part in a million parts). One percent (1%) is equal to 10,000 mg/L. So a 0.1% solids concentration is equal to 1000 mg/L. The solids in domestic wastewater are both dissolved and suspended solids. Suspended solids can be settled out or filtered but dissolved solids will have to be converted to suspended solids during the treatment process.

### BOD AND SUSPENDED SOLIDS

The strength of the wastewater is determined by measuring the amount of suspended material in the water and the amount of organic material in the water. The suspended, filterable solids in the waste flow are known as Suspended Solids or SS. They can be trapped on a filter, dried, and weighed to determine the concentration. The organic strength of the wastewater is determined indirectly. The microorganisms in the biological treatment processes decompose or stabilize the raw organic material in the waste flow. As they do this, they use oxygen as part of the respiration process. Instead of directly measuring the strength of the organic load as pounds of sugars and proteins, we determine the amount of oxygen that the "bugs" use as they eat it. This is known as the Biochemical Oxygen Demand or BOD. If these organics are not stabilized in the treatment process, there will be dissolved oxygen depletion from the receiving water. This oxygen depletion can result in fish kills and damage to the aquatic ecosystem.

Some of the suspended solids are organic, but most of the organics in the wastewater are dissolved. About 40% of the BOD will be suspended particles and most of them will settle out without further treatment. But 60% of the BOD is dissolved and must be used as "Bug Food" to grow a culture of microorganisms that become "suspended solids" that are again removed by settling. Suspended solids are classified as suspended solids and settleable solids. About 60-70 percent of the Suspended Solids in raw wastewater are easily settleable. The rest will have to become settleable solids in the biological processes. Domestic wastewater will have a BOD of between 150-300 mg/L and SS in the 100-400 mg/L range. Nitrogen, in the form of ammonia, will also be present in domestic wastewater. Ammonia concentrations usually run from 10-40 mg/L.

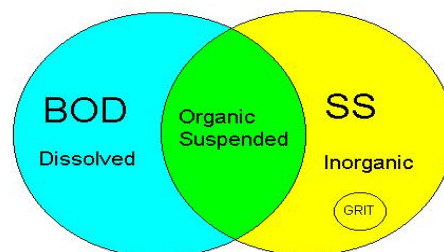

## **INDUSTRIAL WASTEWATER**

Industrial wastewater characteristics vary with each type of discharge. Food processing, dairy operations and meatpacking all have wastes that are very high in BOD, sometimes over 1000 mg/L. This BOD is high in dissolved sugars, fats, and proteins and low in suspended material. It will dramatically increase the loading on the secondary treatment processes. Some food process wastes can also have a high pH, like potato processing and some vegetable canning, or a low pH, like green chili processing or fruit canning.

Toxins, like heavy metals coming from metal plating, battery shops, and heavy equipment manufacturing, and solvents from industries like body shops, dry cleaners, and furniture manufacturing can kill the microorganisms that are needed to treat the waste. Copper, chrome, lead, and cyanide are all chemicals that are commonly found in heavy industrial manufacturing discharges. Hospitals and other medical facilities have the potential to discharge wastes that are radioactive or represent a biohazard.

In some cases, pretreatment of these industrial discharges may be required. Systems that deal with industrial discharges should adopt a pretreatment ordinance to cover conditions that the system may need to impose on the industrial dischargers in order to maintain their NPDES requirements on the treatment plant effluent. If local ordinances are different from specific categorical limits imposed in the Federal Regulations, the most stringent limits of the two must be followed. Pretreatment ordinances can require actual treatment of the industrial waste prior to discharge to the system, or it may levy a monetary surcharge based on the additional loading that results from the discharge.

Any industrial discharger is considered to be a "Significant Industrial User" or SIU if:

- A) The discharge requires pretreatment
- B) The flow is over 25,000 gpd or
- C) The flow is more than 5% of total average plant BOD or hydraulic load.

## **COLIFORM GROUP OF BACTERIA**

Another issue that must be addressed in wastewater treatment is the removal of pathogenic bacteria that can cause water-borne diseases. Wastewater operators need to be mindful of the potential for contact with organisms that are responsible for typhoid, cholera, dysentery, and hepatitis. Blood-borne pathogens responsible for illnesses like HIV are also a concern in wastewater. Wastewater must be disinfected to kill these harmful organisms before it can be discharged. The effluent must be tested for coliform bacteria to confirm proper disinfection.

Coliform bacteria are enteric bacteria. This means that they are found in the intestinal tract of warm-blooded animals, including humans. These bacteria, known as fecal coliform in humans, do not cause disease and necessary for the digestion of food. The waterborne pathogens are also enteric bacteria and are part of the coliform family. Therefore, if fecal coliform bacteria are present, pathogens may also be present. The coliform bacteria live longer in water and are easier to detect in the laboratory. This is the reason the coliform group has been chosen as the indicator organism for waterborne pathogens. If coliform bacteria are not present it is assumed there are no pathogens present either.

## OVERVIEW OF WASTEWATER TREATMENT PROCESSES

Wastewater treatment processes are broadly classified in one of five categories. The first step in wastewater treatment is physical separation of solids from the flow by screening, grinding rags and other debris, and settling out heavy inert grit. This is known as pretreatment or preliminary treatment. Rags and grit make up a small portion of the total amount of solids that must be removed from the waste flow. It is important to remove them first because their presence downstream can create operational and mechanical problems in the other processes.

Primary treatment follows pretreatment. Primary treatment is also a physical removal process. Gravity settling in primary clarifiers removes some of the suspended organic material and over half of the total suspended solids or TSS. Most of the remaining BOD is either dissolved or consists of particles that are too small to settle easily. The BOD that is not removed in the primary clarifiers it will pass on into the secondary treatment process.

The settled sludge is removed to from the clarifier and sent to solids handling facilities for further processing. The sludge may be digested to stabilize it and reduce its volume. After the sludge is properly digested, it is de-watered by mechanical means or sludge drying beds and then composed or landfilled. Some large systems thicken and de-water raw sludge and burn it in furnaces. Although incineration is very expensive from an energy consumption standpoint, it provides the greatest reduction in solids volume for disposal.

Secondary treatment processes are biological processes that make use of bacteria and other microorganisms to eat the organic material that was not removed in primary clarification. This process will stabilize the raw organic material that poses a threat to the receiving water. The organics are stabilized and converted into microorganisms (suspended solids) that can be removed from the process or gases like carbon dioxide. Secondary treatment processes include trickling filters, lagoons and stabilization ponds, rotating biological contactors (RBC's), and several different kinds of activated sludge processes.

A food chain is developed in a secondary treatment process. Bacteria are responsible for most of the organic stabilization. As the bacteria reproduce, the organics are converted into suspended solids. The bacteria represent the bottom of the secondary food chain. The bacteria are eaten by small single celled water creatures, called protozoa, which are in turn eaten by larger multi-celled organisms. These larger organisms can be removed in a clarification process as secondary sludge.

Tertiary treatment processes follow secondary treatment. They cover a wide range of treatment options. Polishing ponds for bacteria and BOD removal have been added to secondary trickling filter plants to improve the overall plant removal efficiency. Tertiary filter processes can be used to remove suspended solids. Nutrient removal processes are also considered to be tertiary treatment processes. Nitrification/denitrification, ammonia stripping, phosphorous precipitation, and land application/overland flow processes may be used in cases where nutrient removal is required to meet a system's discharge permit.

The final process in wastewater is disinfection. Disinfection is required to destroy pathogenic organisms in the wastewater effluent. Chlorination is the most common means of disinfecting wastewater. The problem is that chlorine will also harm aquatic life in the receiving water. Many systems that chlorinate are also required to dechlorinate to remove the chlorine residual before the effluent is discharged. More and more systems have turned to alternative methods of disinfection to get away from the chlorination/dechlorination issues. The most popular alternatives are ultra-violet (UV) radiation and ozonation.

## **NPDES REGULATIONS**

The Clean Water Act of 1970, and the Federal Water Pollution Control Act Amendments of 1972, established the National Pollutant Discharge Elimination System or NPDES in an effort to assure that wastewater discharges would not adversely affect aquatic recreation or wildlife. The Clean Water Act was legislated at the federal level and it is administered through the United States Environmental Protection Agency (USEPA). However primacy, or the responsibility for enforcement of the regulations, is given to the individual states. Each state must identify a primacy agency to handle these enforcement duties. The primacy agency in New Mexico is the New Mexico Environment Department (NMED). In Arizona, the primacy agency is the Arizona Department of Environmental Quality (ADEQ). Tribal systems may report directly to the USEPA or an internal primacy agency like the Navajo EPA for the Navajo Nation.

The NPDES permit identifies monthly averages and maximum levels of BOD, Suspended Solids, and Fecal Coliform allowed in the treatment plant effluent. In larger systems, and systems that discharge into sensitive surface waters or groundwater supplies, NPDES permits may also require removal of nitrogen and phosphorous. The NPDES permit will also specify the frequency of sample collection and methodology for reporting the results. Systems that have irrigation systems or sub-surface disposal fields will also be required to drill wells to monitor groundwater contamination in the area. This is known as an Aquifer Protection Permit.

## **WASTEWATER TREATMENT BACTERIA**

The stabilization of organics in wastewater is accomplished bacteria in both secondary and tertiary treatment processes and in sludge digestion. There are three types of bacteria responsible for the decomposition of BOD in wastewater.

Aerobic bacteria are used in secondary treatment processes. They must have dissolved oxygen present in the water to survive. As they break down the organic material they release carbon dioxide. When wastewater has dissolved oxygen for aerobic activity, it is sometimes called fresh sewage. It has a dishwater gray appearance and few objectionable odors.

Anaerobic bacteria cannot reproduce in wastewater that has dissolved oxygen present. In the absence of DO, the anaerobic bacteria will break down organics and release carbon dioxide (CO<sub>2</sub>), methane (CH<sub>4</sub>), and hydrogen sulfide (H<sub>2</sub>S). These three gases are referred to as sewer gases because they are often found in wastewater collection systems.

Methane is explosive. Hydrogen sulfide is a deadly nerve agent that can cause paralysis and death. Carbon dioxide is a safety hazard because it will displace oxygen in the atmosphere in confined spaces. Anaerobic decomposition is most commonly used in anaerobic sludge digesters. The methane that is produced can be used as an energy supply to heat the digester and sometimes generate electricity. Other objectionable odors that result from anaerobic decomposition include sulfur compounds called mercaptans and thiols.

Facultative bacteria can act like aerobic bacteria in the presence of oxygen or anaerobic bacteria if there is no DO available. They can be found in all types of biological treatment processes because of their adaptability. They are usually associated with facultative stabilization ponds.

## **pH AND WASTEWATER**

The pH of the water is the measurement of the acidity of the water. Water, or wastewater, is considered to be acidic when it has more hydrogen ions ( $H^+$ ) present than hydroxide ions ( $OH^-$ ). Some of the chemicals that add hydrogen ions ( $H^+$ ) to the water are hydrochloric acid, HCl, sulfuric acid,  $H_2SO_4$ , nitric acid,  $HNO_3$ , and carbonic acid,  $H_2CO_3$ .

Water is considered to be alkaline when there are more hydroxide ions ( $OH^-$ ) present than hydrogen ions ( $H^+$ ). Sodium hydroxide, NaOH, calcium hydroxide,  $Ca(OH)_2$ , and magnesium hydroxide,  $Mg(OH)_2$ , all add hydroxide ions ( $OH^-$ ) to the water. When the number of hydrogen ions and hydroxide ions are the same the water has a neutral pH. Pure water,  $H_2O$  or H-OH, has a neutral pH because the number of hydrogen ions ( $H^+$ ) and hydroxide ions ( $OH^-$ ) are equal.

<b>pH SCALE</b>														
0	1	2	3	4	5	6	7	8	9	10	11	12	13	14
							^							
More Acid							Neutral	More Alkaline						

The pH of water is measured on a scale that reads from 0 to 14. The midpoint of the scale is 7. Water with a pH of 7 is neutral. If the water has a pH less than 7, the water is acid and if the pH is greater than 7 it is alkaline. For every whole number that the pH changes the strength of the acid or alkaline properties of the water will change by a factor of ten times. Water that goes from a pH of 9 to a pH of 10 becomes 10 times more alkaline and water at pH of 5 is 10 times more acid than water at a pH of 6.

## **EFFECTS OF TEMPERATURE AND pH ON BIOLOGICAL ACTIVITY**

Most biological activity occurs when the water temperature is between 50-85°F. Some anaerobic digestion processes operate at temperatures of over 100°F. Our wastewater bugs become less active when the temperature drops. A temperature drop of 10°C (18°F) will cause a 50 percent reduction in biological activity. This means that process adjustments must be made during the winter months to compensate for the drop in water temperature in the treatment processes.

All three types of the wastewater treatment bacteria operate most efficiently at a pH of 6.8-7.2. When the pH drops below 6.0 or rises above 8.5, activity drops off dramatically. Bioactivity in wastewater treatment processes tends to lower the pH. This happens because carbon dioxide that is released in the decomposition process reacts with water to create carbonic acid. Industrial wastes that create abrupt changes in pH can cause serious upsets of the secondary processes.

## **DAILY FLOW FLUCTUATIONS**

The flow at the treatment plant will fluctuate with the changes in water usage by its domestic customers. At night water usage is low and so is the flow at the treatment plant. In the morning, usually between 6:00-8:00am, water usage increases and so does the flow to the plant. But it takes several hours for the wastewater to make its way through the collection system. So that peak flow usually hits the treatment plant between 9:00-10:30am.

This peak flow can be as much as two and a half times the daily average flow. The flow will spike again between 6:00-8:00pm, which correspond with the evening peak water usage. Treatment process adjustments must be made to compensate for the high and low flows that will affect the hydraulic loading on the plant. A higher flow rate will result in decreased detention time in treatment processes and can adversely affect treatment by increasing the surface loading rate in the clarifiers.

Some systems are designed with equalization basins in the headworks. The purpose of flow equalization is to retain water during higher flow periods. The stored water can be treated later in the day when the plant flow drops. This reduces the hydraulic “bump” from sudden flow surges that can cause a loss of solids from the system.

## THE CARBON CYCLE

Decomposition of organic matter in wastewater involves the oxidation of the raw organics into stable compounds. The two most important cycles of decay are the cycles for carbon and nitrogen. Organisms that feed on carbon based sugars and nitrogen based proteins require oxygen for the respiration process. If this is not accomplished in the treatment process, the result will be oxygen depletion of the receiving waters and harm to the aquatic life that also needs dissolved oxygen to survive.

The carbon cycle begins with organic carbon that is in the waste stream. Bacteria decompose the organic carbon as they eat it and release carbon dioxide. Plants take in carbon dioxide to make plant sugars, starches, and other plant carbohydrates through photosynthesis. Animals eat the plants and use the carbohydrates to make animal fat and protein. The animal waste products are the organic carbon that we started with at the top of the cycle. Most of the BOD in wastewater treatment is sugars and carbohydrates.

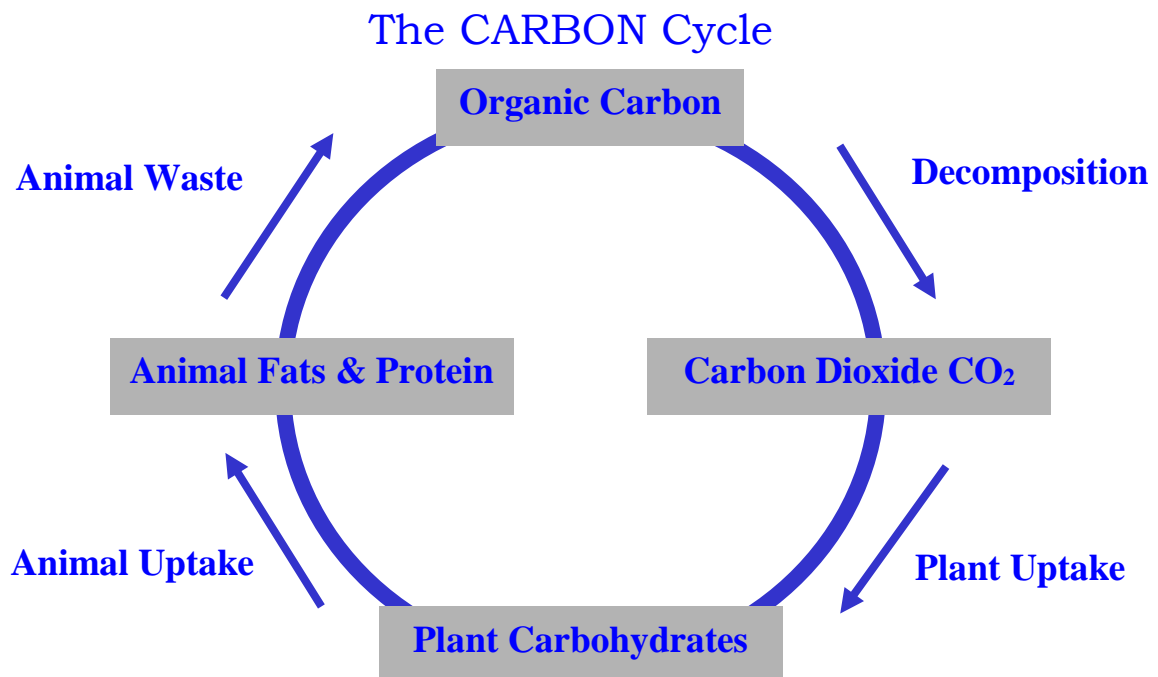

## THE NITROGEN CYCLE

The nitrogen cycle is more complex than the carbon cycle. The first step in the stabilization of nitrogen-based organics (primarily proteins) is the decomposition of organic nitrogen into ammonia. Ammonia levels in domestic wastewater are normally between 10-40 mg/L. In the second step nitrogen bacteria oxidize the ammonia and change it to nitrites. Nitrite nitrogen is still unstable and will create an oxygen demand in the receiving water. The third step is further oxidation to create nitrates, which are the most stable form of nitrogen. Plants and animals will use the nitrates to create plant and animal proteins and their waste products again become organic nitrogen.

Nitrate nitrogen is a nutrient that can encourage plant growth in the receiving waters. Many of today's tertiary treatment systems are designed to denitrify or remove the nitrates. Under anoxic conditions, facultative bacteria remove the chemically bound oxygen on the nitrates for respiration and release nitrogen gas to the atmosphere.

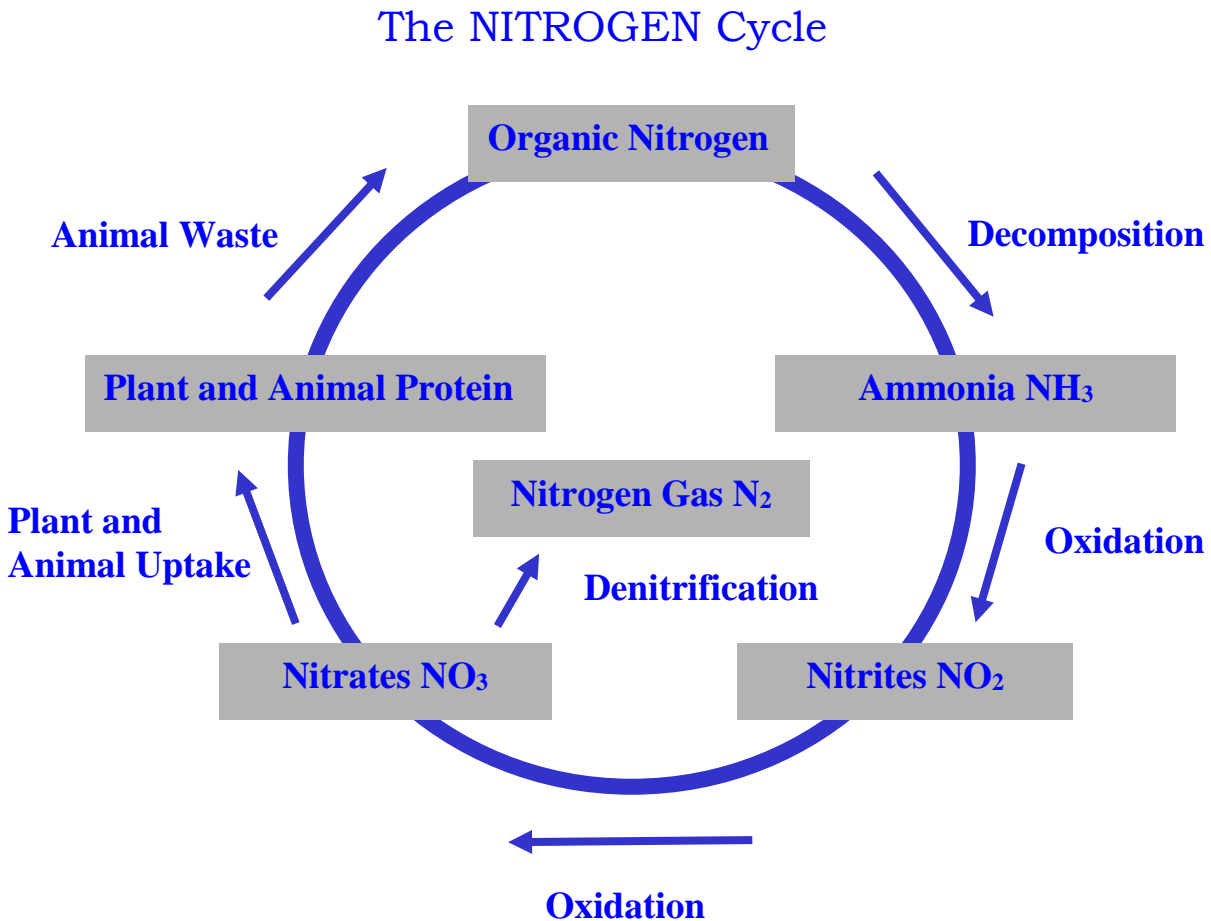

### **BASIC STUDY QUESTIONS**

1. How do the three types of bacteria in wastewater treatment differ?
2. What is the normal range for BOD and SS in domestic wastewater?
3. What is the difference between a primary treatment process and a secondary treatment process?
4. What are the three sewer gases released during anaerobic decomposition?
5. What does NPDES stand for?
4. Most secondary processes make use of which type of bacteria:
  - A. Anaerobic
  - B. Aerobic
  - C. Nitrogen fixers
  - D. Methane fermenters

### **ADVANCED STUDY QUESTIONS**

1. What is the most stable form of nitrogen in water?
2. What parameters can be included in an NPDES discharge permit?
3. What are some of the characteristics of different industrial wastes?

### **BASIC SAMPLE TEST QUESTIONS**

1. The peak flow period at the treatment plant will be between
  - A. 3:00-5:00am
  - B. 6:00-8:00am
  - C. 9:00-10:30am
  - D. 9:00-11:00pm
2. What effect do colder temperatures have on biological activity?
  - A. Bioactivity decreases
  - B. Bioactivity increases
  - C. Temperature does not affect bioactivity
3. Most wastewater "bugs" like a pH around:
  - A. 3.5-5.5
  - B. 6.8-7.2
  - C. 8.3-9.5

### **ADVANCED SAMPLE TEST QUESTIONS**

1. Ammonia discharged to receiving streams is a problem because:
  - A. It represents BOD
  - B. It will cause oxygen depletion in the stream
  - C. It increases the suspended solids
2. Normal biological activity in secondary treatment processes tends to:
  - A. Cause an increase in DO
  - B. Raise the pH
  - C. Lower the pH
  - D. Has no effect on pH



## PLANT PRETREATMENT

The removal of solids from the incoming wastewater flow is accomplished in steps. These steps involve physical separation of the solids by screening and by gravity. The larger solids can be removed using screens and the heavy solids can be removed using settling processes. The dissolved organic material (and some of the lighter suspended solids) will remain in the sewage flow after primary clarification.

The first step in the solids removal process is screening to remove the larger solids and rags. After screening, a grit removal process is used to separate the heavier inorganic solids like sand and non-degradable organics like coffee grounds from the flow. Rags can clog piping and pumps in downstream processes. Grit can also cause clogging problems and can damage pumps. Grit that isn't removed in the grit chamber will end up in the solids handling system where it will eventually collect in the digesters. Over time this will reduce the digester capacity and detention time. These processes that remove inorganic solids are collectively referred to as pretreatment. This front part of the plant is also called the headworks.

### BAR SCREENS

A bar screen consists of a rack of steel bars that are placed vertically in the influent flow channel. The bars are usually spaced about 1/2-3/4 inches apart. In some cases, two sets of screens are placed in the channel the upstream screen may have bars spaced 2-3 inches apart and the downstream screen will have the normal spacing. The front screen is sometimes referred to as a trash screen. It is designed to catch large chunks of debris and avoid overloading the smaller screen. As the screen gets clogged with rags the water level upstream will rise. If the screen isn't cleaned regularly the upstream water level can back up and flood the structure.

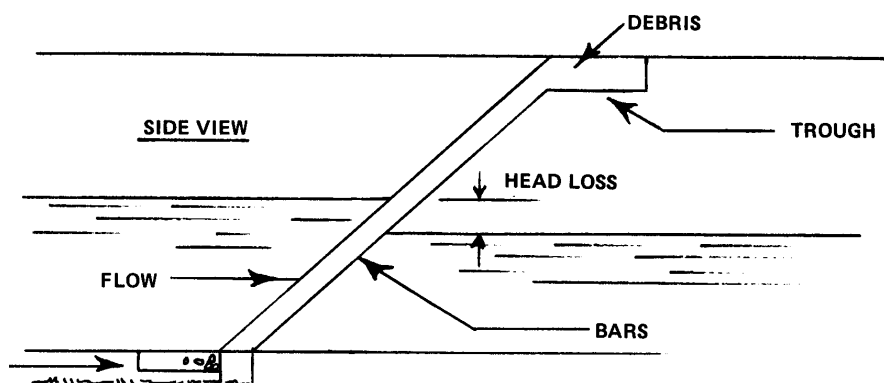

### Manually Cleaned Bar Screen

An operator must rake the collected debris from a manually cleaned bar screen. Manually cleaned bar screens are usually set at a 45-degree angle. This makes it easier and safer to rake the debris from the screen.

Automatically cleaned bar screens are designed with a set of rakes that are chain-driven. These units will operate periodically to remove the rags and deposit them in some type of container. The bar screen angle is usually between 60 and 90 degrees on an automatically cleaned screen system. The rags that are removed by the screen must be hauled to a landfill for disposal. However, some screen systems actually rake the screens, grind or shred the rags, and then return them to the waste flow.



Incoming septic sewage can cause corrosion problems with steel screens. Hydrogen sulfide formed by anaerobic decomposition will attack the metal bars. Bar screens should be inspected several times a year for corrosion and bent bars. Repair and replacement of the bars is the only maintenance issue for manually cleaned screens. Automatically cleaned screens need to have weekly inspections to check the conditions of the rake teeth and the chain drive.

**Bar Screens are used to separate large debris such as rags and plastics.**

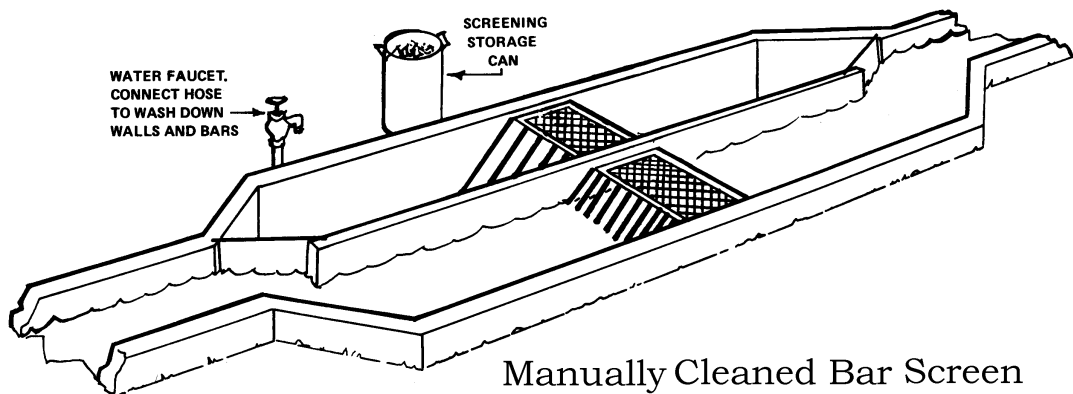

Manually Cleaned Bar Screen

## COMMINUTORS AND GRINDER PUMPS

A comminutor is a device that is designed to shred rags and debris into small pieces. It takes the place of a bar screen. Debris collects on the cage of the comminutor and a set of revolving teeth cut the rags up into pieces small enough that they won't clog pumps and pipes. Grinder pumps or macerators, such as the "Muffin Monster," also grind up debris as it flows through the pump. Comminutors or grinders will normally be placed in parallel with a manually cleaned bar screen. The bar screen is usually set up in parallel so it can be used when the comminutor is down for service.

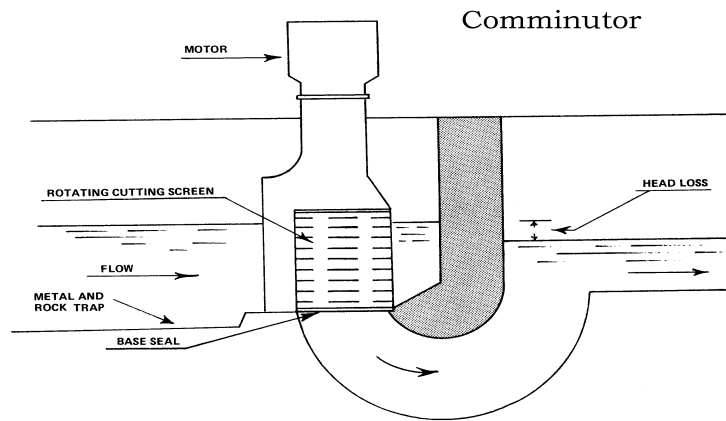

**Comminutors grind rags into small chunks instead of removing them.**

The advantage to chopping up the rags is that it eliminates the need to collect and landfill the debris. However, the chopped up rags can still become a problem in solids handling processes because they are now removed with the primary sludge. Like automatically cleaned bar screens, comminutors and barminutors have higher maintenance cost than manually cleaned screens. The most important item is the inspection of the cutting assembly. When the cutting teeth get worn the risk of jamming the cutting assembly increases. If worn cutting blades are not replaced, and the unit suddenly becomes jammed, shear pin failures can occur.

## BARMINUTORS

A barminutor is a combination of a bar screen and a comminutor. The bar screen traps the rags and a rotating cutter up and down the screen to cut up the rags. Like some automatic bar screens, the barminutors only operates when there is enough debris to raise the upstream water level. Gearboxes and bearings must be kept full of grease to prevent water intrusion. If too much debris builds up on the bars the cutter can jam. Shear pin failures are also common with this equipment.

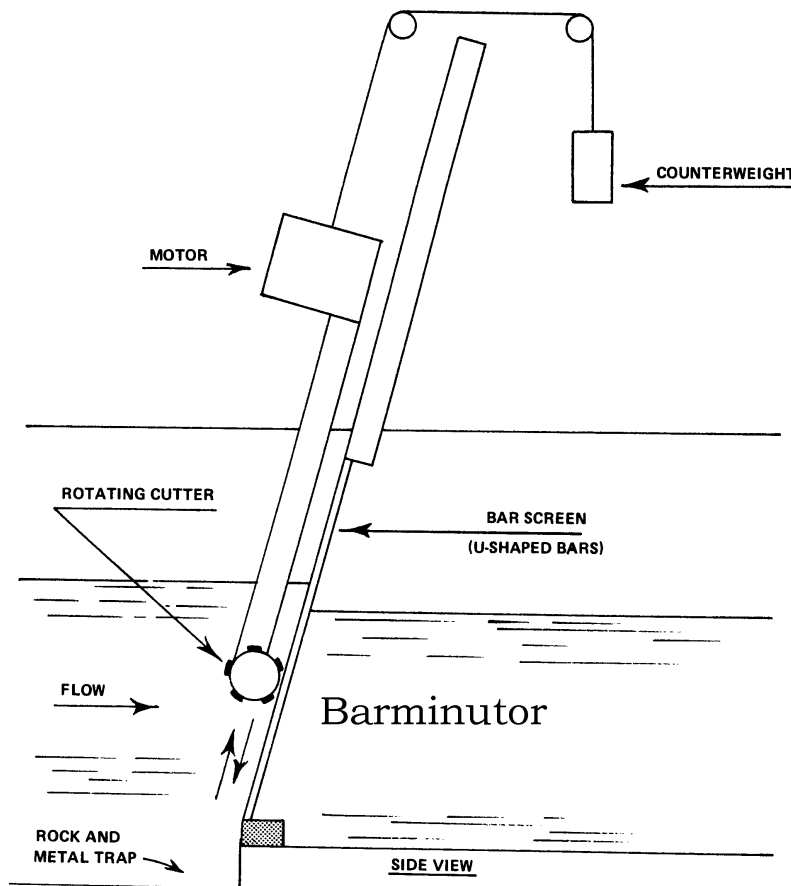

## GRIT CHAMBERS

The downward slope of a sewer line must be sufficient to maintain a minimum velocity of 2 feet per second in the pipe. The 2 fps velocity will prevent grit from settling in the sewer lines. This velocity is maintained until the flow enters the treatment plant. The grit is removed from the flow as it passes through a grit chamber. The velocity in the grit chamber is reduced to about 1 foot per second. When the velocity drops to 1 fps, the heavier grit particles will settle out and the lighter organic material will stay in suspension and continue on into the primary clarifiers. There are several different designs for grit chambers.

The first grit chambers were rectangular channels 30 to 60 feet long. A proportional weir at the effluent end of the channel would create a water depth that reduced the velocity to 1 fps. There were usually two of these grit chambers installed in parallel. Drop gates were used to isolate a channel so that the collected grit could be shoveled or removed with a clamshell bucket. The grit that comes out of the grit chamber may still have some organic material in it. It can be washed, or classified, to remove the organics in an effort to reduce objectionable odors. Grit material should also be landfilled.

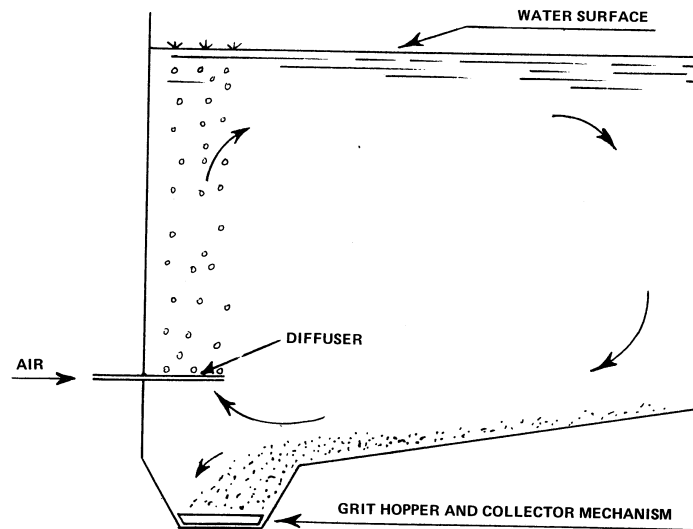

Aerated Grit Chamber

Aerated grit chambers are much larger and deeper than non-aerated units. The 1 fps velocity is maintained by using aerators to create a rolling flow in the tank. The detention times are increased to 10-45 minutes. This also helps create aerobic conditions in septic sewage. Aerobic conditions help improve the settleability of the sludge and increase both BOD and suspended solids removal in the primary clarifiers. Aeration is achieved using diffusers located on the bottom of one side of the grit chamber. As the rolling motion is established, the grit collects at the bottom of the tank.

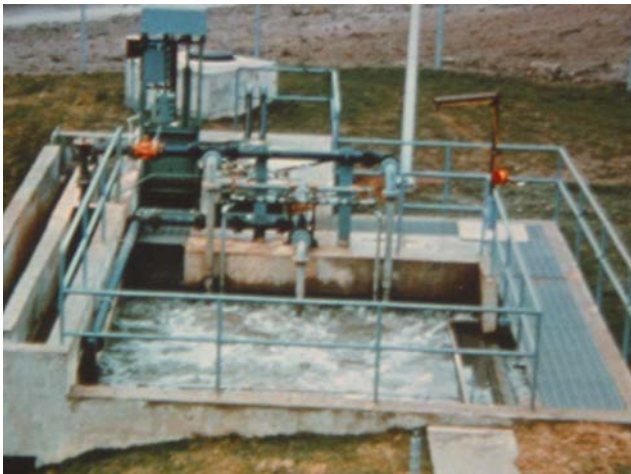

Mechanical augers at the bottom of the grit chamber move the grit to one end of the tank where grit slurry pumps can pump it out of the tank to a grit separator.

Bucket chains may also be used to bring grit out of the basin. When the buckets are coming up full, the speed should be increased. If organics start showing up in the grit, the air flow should be increased.

Aerated Grit Chamber

The most common type of grit separator is called a cyclone separator. Water and grit are pumped into a cylinder that tapers to a cone on one end. The flow whirls around the inside of the cylinder like a cyclone. Centrifugal force slings the heavy grit to the outside, where it slowly works its way to the bottom of the cone. The water overflows from the cylinder end and is returned to the waste stream.

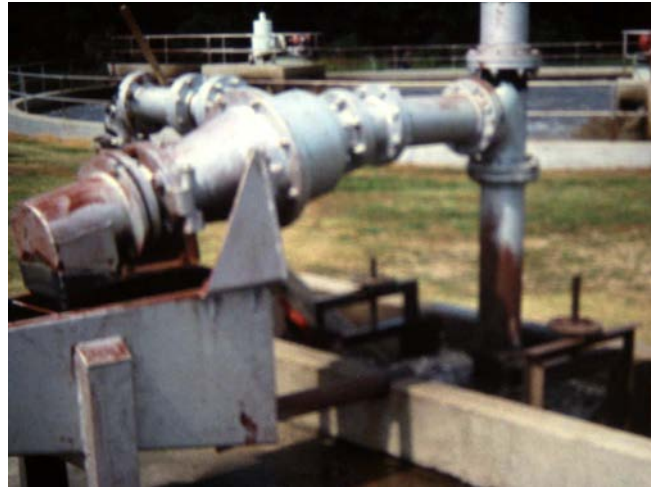
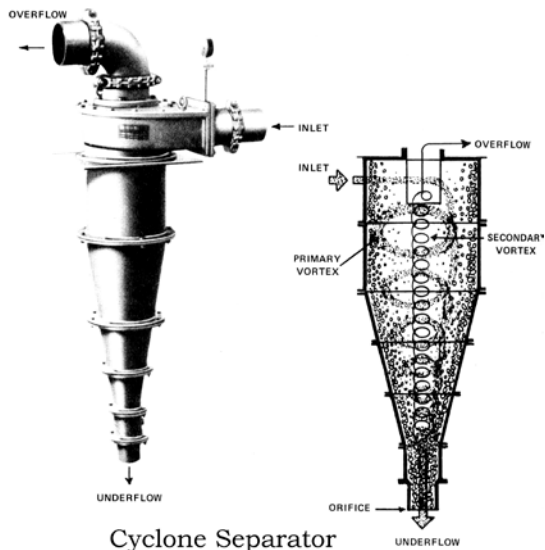

**Grit is separated and deposited in a grit classifier (left side) and the water is returned as a sidestream (right side).**

## FLOW MEASUREMENT

The rate of flow through the treatment plant is a very important piece of operational data. It is used to calculate process hydraulic and organic loading, detention time, surface loading rates, and weir overflow rates in the various treatment processes. The flow measurement readings for the plant are taken at the head works, either before or after the pretreatment processes. Open channel flow measurement is the most common means of measuring wastewater flows.

## OPEN CHANNEL WEIRS

A weir is a sharp-edged plate that is inserted into an open channel for the purpose of gauging the flow in the channel. Weir plates can be V-notched, rectangular, or trapezoidal, like the Cipoletti weir. The V-notch weir is used for small flows. The rectangular weir is used for high flows. The Cipoletti weir is basically a combination of the V-notch and rectangular opening. Proportional weirs are used to maintain the proper velocity in an open channel grit chamber.

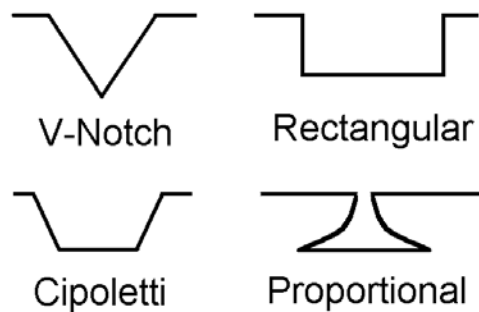

## MEASURING FLOWS IN OPEN CHANNELS

The flow over a particular weir is determined by measuring the depth of water going over the plate. This depth can be converted to a flow with a weir flow chart. In order to gauge the depth accurately, the measurement must be taken at a point upstream of the weir plate.

The depth measurement must be taken upstream from the weir at a distance at least 2.5 times the water depth. The main disadvantages of using weirs to measure influent flows are that debris can get hung up on the sharp edge, creating an inaccurate depth reading, and grit can settle upstream of the weir plate.

Taking Weir Depth Measurements

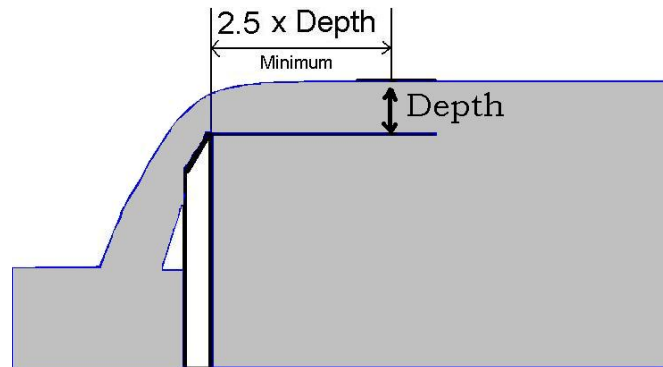

## PARSCHALL FLUMES

Small systems may be able to use weir plates to measure influent flows. Larger plants will use a Parschall flume as the measuring device. Parschall flumes measure a wide range of flows with acceptable accuracy and they have no sharp edges that can catch debris.

## Parshall Flume

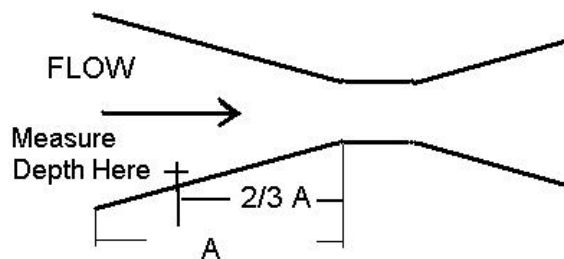

The velocity through the flume increases. This prevents grit from collecting. A Parschall flume is shaped like an hourglass. As the flow increases, the upstream depth increases. Like a weir, the depth of the water in the flume must be measured at a stable point upstream of the neck. This point is two-thirds of the distance from the neck to the front of the flume.

## **FLOW EQUALIZATION BASINS**

Treatment processes would work better if the flow through the plant were constant. Unfortunately, the flow through the system fluctuates on a daily basis. Treatment plant operators learn to adjust operating parameters when these fluctuations occur. Most of the time these changes need to happen in preparation for the flow change. If changes are made as a reaction after the fact, it will be much more difficult to control the biological processes.

Flow equalization basins are designed to smooth out the hydraulic and organic peaks that occur during the day. These basins can be designed as a flow-through part of the process or they can be side-streamed during peak flows and later metered back into the plant in the evenings when the flow drops down. The diverted flows must be returned daily. The contents of the equalization basin must also be aerated and mixed during storage. This will prevent the sewage from going septic and also prevent sludge from accumulating in the basin.

They can also prevent hydraulic washouts that can occur during storms provided the event is short lived. The resulting inflow and infiltration can raise the flows to levels that can threaten many activated sludge processes. In older systems where infiltration is a problem, the flows may stay abnormally high for several days. Equalization basins won't help if the flow can't be returned to the system on a daily basis.

Splitter boxes are used when parallel processes exist. If there are three primary clarifiers, the flow should be split evenly to achieve the best overall removal rate. The gates in a splitter box must be adjusted to achieve this. Check the depth of the water in each primary clarifier effluent channel as adjustments are made. When the depths in the channels are the same the flows are split evenly.

### **BASIC STUDY QUESTIONS**

1. What do bar screens remove?
2. How does a grit chamber work?
3. What is a weir used for?

### **BASIC SAMPLE TEST QUESTIONS**

1. What is the best angle for a manually cleaned bar screen?
  - A. 10 degrees
  - B. 30 degrees
  - C. 45 degrees
  - D. 90 degrees
2. Where do screenings go?
  - A. To the digester
  - B. To the landfill
  - C. To the recycling station
  - D. Back into the flow
3. A comminutor is used:
  - A. To measure flow
  - B. To digest inorganic solids
  - C. To grind up rags and debris
  - D. To call the plant manager
4. The velocity in a grit chamber should be about:
  - A. 1 foot per second
  - B. 2 feet per second
  - C. 4 feet per second
  - D. 10 feet per second

### **ADVANCED STUDY QUESTIONS**

1. As a bar screen gets clogged, what happens to the upstream water level?
2. Where should you take a depth reading on a parshall flume?
3. What should you do if you notice an increase in organic materials in the grit from an aerated grit chamber?
4. What is the purpose of a flow equalization basin?

### **ADVANCED SAMPLE TEST QUESTIONS**

1. The detention time in an aerated grit chamber should be:
  - A. 15-30 seconds
  - B. 1-3 minutes
  - C. 5-10 minutes
  - D. 15-40 minutes
2. A weir measurement must be taken:
  - A. At the notch
  - B. 2.5 times the depth upstream
  - C. 2.5 times the depth downstream
  - D. With a sludge blanket locator



## PRIMARY TREATMENT

Primary treatment is the next step in the wastewater treatment process. Pretreatment removed the rags and inorganic grit. Primary treatment will remove the majority of the suspended solids that are present. This is another physical treatment process. Grit chambers sort out the heavy grit and primary clarifiers remove heavy organic solids in order to reduce the organic loading on the secondary processes. Primary clarifiers are used to slow the velocity of the water to a point where organic solids will settle to the bottom of the tank. This primary sludge is collected and sent to the solids handling processes. Primary clarifiers also contain equipment that is used to remove floating solids and greases from the surface. Lagoon systems and some activated sludge processes like extended aeration will not have primary clarification.

The solids that are present in the primary influent are classified as settleable and suspended solids. Suspended solids represent all of the remaining particles. Some of the solids are large enough and heavy enough that they will settle out very quickly. These solids are called settleable solids. The settleable solids represent about 30-60% of the total suspended solids. Primary clarifier removal efficiencies vary with changes in flow, temperature or solids loading.

Primary Clarifiers Remove
<ul style="list-style-type: none"><li>• 90-95% of the settleable solids</li><li>• 40-60% of the suspended solids</li><li>• 30-40% of the BOD</li></ul>

### PRIMARY CLARIFIERS

Wastewater treatment plants will use either rectangular or circular primary clarifiers. Every clarifier can be divided into five zones:

The **Influent Zone** is inlet to the clarifier. Water enters the end of a rectangular tank, or the center of a circular tank. The influent zone is equipped with a baffle. Circular tanks will have a collar-type circular baffle that directs the water down as it enters the center of the tank. Rectangular tanks will have a perforated wall that spreads the water laterally across the influent end of the tank. The purpose of the baffle is to prevent short-circuiting. Short-circuiting reduces the detention time in parts of the tank causing solids to carry over into the secondary process and resulting in uneven sludge distribution.

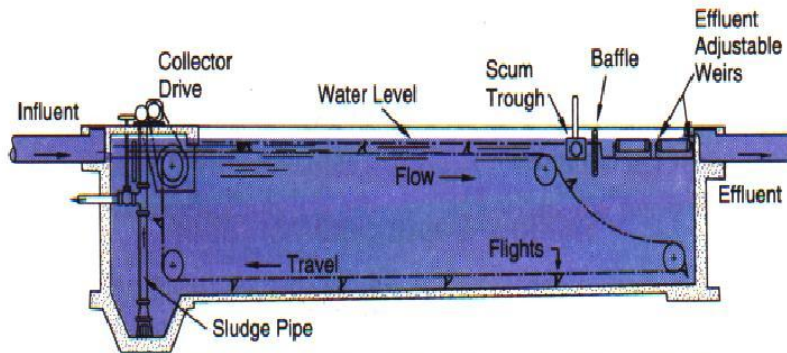

## Rectangular Clarifier

The **Settling Zone** represents the largest portion of the tank. The water velocity is reduced to 0.03-0.05 fps and the detention time should be about 2 hours. The problem is that the flow rises and falls during a 24-hour period. As the flow increases the detention time decreases. Slowing the water down for this long allows the sludge to settle to the bottom while the water is removed from the top of the tank. Clarifiers are usually only about 8-12 feet deep and have a surface loading rate of about 800-1400 gpd/sq ft. This keeps the upward velocity of the water low enough to minimize solids carryover.

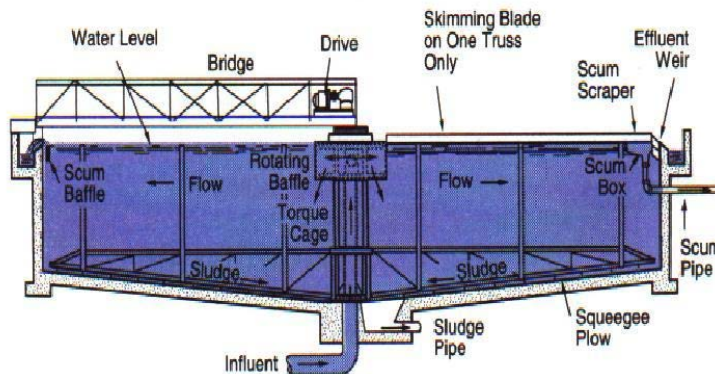

## Circular Clarifier

The **Skimming Zone** is at the surface of the tank. Solids and greases that have a specific gravity of less than 1.0 will float to the surface of the clarifier. A skimmer arm is attached to the rake assembly. It skims the surface as the rake rotates. In a rectangular tank the sludge rakes act as skimmers when the chain brings them to the surface. Floating scum is deposited in a grease or scum hopper. This grease and scum must be properly landfilled to prevent odor problems.

The **Effluent Zone** is the part of the tank where the settled water leaves to go to the secondary treatment processes. In rectangular tanks the water leaves at the end opposite the influent. In circular or square tanks the water leaves at the edge of the tank. A channel called the effluent launder collects the effluent flow and directs it to the effluent piping. Weirs are installed along the edge of the effluent launder to skim the water evenly off the surface of the tank. The most common type of effluent weir is a V-notch (or saw-tooth) weir. A V-notch weir is a plate that has notches, about 2-3 inches deep, cut in it every 6-8 inches. If the weir is clean and level, it will remove water evenly all the way around the edge of the tank. This minimizes the upward velocities near the effluent launder and improves removal efficiencies.

If the weir plate is not level, or part of the weir becomes clogged with slime or debris, short-circuiting will result because more water will pass over the low side or the clean notches of the weir. Short-circuiting will cause poor settling and uneven sludge blanket buildup. A baffle plate, a ring 6-8 inches inside the weir, is installed to prevent floating solids from going over the weir. The design criterion for weirs is the weir overflow rate. The weir overflow rate establishes how many gallons can pass over each foot of weir each day. The standard weir overflow rate is between 20,000-25,000 gpd/ft.

The **Sludge Zone** is the bottom of the tank where the settled sludge collects and compacts. Sludge blanket depth should be measured and sludge should be removed at least every shift. Sludge rakes push the sludge to one end or the center of the tank so that it can be pumped out. The rake drive is usually equipped with a torque indicator. The torque indicator resembles the indicator on a torque wrench. A needle moves across a graduated scale that indicates how much force is needed to move the rake through the sludge. If too much torque is applied, a shear pin in the drive shaft will break to prevent damage to the gearbox or drive shaft. A fluctuating torque reading indicates uneven sludge buildup in the sludge zone. Short-circuiting in the unit causes this uneven distribution of sludge.

Failure to remove sludge often enough will result in anaerobic conditions and gas buildup in the sludge. The sludge can become septic, releasing gas bubbles, and float to the top where it can be difficult to remove. It can also result in increased odor problems.

**The sludge rake moves sludge to the sump located in the center of the tank.**



## **PRIMARY SLUDGE PUMPING**

Primary sludges must be removed frequently in order to minimize odor problems and prevent sludge from going septic. Septic sludges are much more difficult to thicken or dewater. The frequency depends on solids handling capability, solids and hydraulic loading, and pumping capacity. Sludge is usually removed every 2-4 hours. Primary sludge pumps are positive-displacement pumps.

The pumping cycles must be designed to provide the thickest sludge possible. This is a balancing act between allowing the sludge to concentrate and removing it before it turns septic or creates too much load on the rake mechanism. Primary sludge normally averages 4-6% solids. Pumping large amounts of sludge over a short period of time can create a hole in the sludge blanket and drop the solids concentration in the sludge dramatically.

## **SECONDARY CLARIFIERS**

There are minor differences between primary and secondary clarifiers. Secondary clarifiers may not have skimming equipment. The sludge removal equipment may also be different in activated sludge processes. Secondary sludges have lower solids concentrations. Trickling filter sludge will be 1.5-2.0% solids and return activated sludge will be about 0.5-0.8% solids. The solids inventory in activated sludge clarifiers can impact SVI and MLSS results and must be taken into account. When sludge sits in the secondary clarifier too long, denitrification can occur. Nitrogen gas will be released, causing the same rising sludge problems that occur in primary clarifiers.

The sludge from activated sludge clarifiers must be removed continuously. This Return Activated Sludge (RAS) consists of microorganisms from the aeration system. They must be returned to the aeration basins as soon as they get to the bottom of the clarifier. If they are allowed to stay in the clarifier too long they will get sick and won't perform the way they should once they are back in the aeration basin.

The depth of the sludge should be checked with a sounding device known as a sludge judge. It should be used to check the sludge blanket twice a shift. It should be checked every two hours whenever the pumping rates are changed.

### **BASIC STUDY QUESTIONS**

1. What is the difference between settleable and suspended solids?
2. What is short-circuiting?
3. What is the normal sludge pumping frequency?
4. What happens when sludge is removed too fast?

### **BASIC SAMPLE TEST QUESTIONS**

1. Primary clarifiers should have a detention time of:
  - A. 30 minutes
  - B. 1 hour
  - C. 2 hours
  - D. 4 hours
2. What should the suspended solids removal efficiency be in a primary clarifier?
  - A. 10-20%
  - B. 20-30%
  - C. 40-60%
  - D. 90-95%
3. If the weir notches are clogged:
  - A. Short-circuiting can occur
  - B. The sludge blanket depth will increase
  - C. Odors are created
  - D. Grit is easier to remove

4. The solids concentration in primary sludge should be:
  - A. 1-2%
  - B. 4-6%
  - C. 10-15%

### **ADVANCED STUDY QUESTIONS**

1. What does an increase in the torque indicator reading mean?
2. What causes rising sludge in secondary clarifiers?

### **ADVANCED SAMPLE TEST QUESTIONS**

1. What is the normal BOD removal efficiency in a primary clarifier?
  - A. 5-10%
  - B. 30-40%
  - C. 60-80%
  - D. 90-95%
2. Sludge blanket depth readings should be taken:
  - A. Twice a shift
  - B. Once a day
  - C. Once a week
3. What happens when the flow increases?
  - A. Detention time decreases
  - B. Velocity increases
  - C. All of the above



## SOLIDS HANDLING

Solids handling, digestion, and disposal take almost as much expense and manpower to operate and maintain as the rest of the plant. The sludge thickening processes are designed to decrease the amount of water that is handled by increasing the solids concentration in the sludge. If you can double the solids concentration, the amount of water needed to move a pound of solids is cut in half. Most anaerobic digesters have to be heated. Each gallon of water must be heated from 60-70 degrees F to 94-96 degrees F. If you have to pump more water to the digester, the cost of heating the digester increases and the process detention time is reduced. Less water to the digester also means less chance of an upset do to temperature fluctuations and less supernatant returning to the head of the plant.

### GRAVITY THICKENERS

A gravity sludge thickener is a scaled down clarifier. The process is identical but the unit is designed for heavier sludges and lower flows. Surface loading rates are about 400-800 gpd/sqft. Detention times vary from 1-2 days. The solids loading on the unit is calculated in pounds per day/sqft. The efficiency of the process is dependent on three factors: the solids concentration, the settleability of the sludge, and the temperature. Secondary sludges and waste activated sludge in particular are more difficult to handle than primary sludges. Primary sludge will normally run 4-6% solids (94-96% water) while trickling filter sludges will be about 1-2% solids and waste activated sludge will run about 0.5-1.0% solids. Blending secondary sludges with primary sludge in a gravity thickener may improve the overall solids concentration, but activated sludge may require additional treatment like dissolved air floatation (DAF) prior to blending.

The sludge rakes and drive mechanism must be able to handle the heavier solids in a gravity thickener. There are vertical pickets attached to the rake assembly. These pickets help mix the blended sludges and aid in the release of gases to prevent rising sludge in the unit. If sludge stays in the thickener too long it will become septic. This can result in odor problems and floating solids. Septic sludges are the most difficult to de-water. This means higher dosages of chemicals like polymer in DAF units or centrifuges and lime in vacuum filters and belt presses will be required.

The operational control parameters for gravity thickeners include detention time, sludge blanket depth, and sludge withdrawal rate. The detention time should be shorter in warm weather. Sludges settle better in warm water and increased biological activity means that the sludge will go septic faster. Sludge blanket depth should be between 5-8 feet deep. Sludge blanket depth will affect detention time, creating shorter detention times as the blanket depth increases. The withdrawal rate should be adjusted to maintain a constant sludge blanket depth. The Sludge Volume Ratio (SVR) is used to control the sludge retention time in the thickener. It compares the sludge solids concentration to the sludge blanket depth much like SVI in activated sludge.

The removal efficiency of a gravity filter is determined by comparing the suspended solids concentration in the effluent to the concentration in the influent (expressed as mg/l instead of percent). As an example, if the effluent SS is 800 mg/l and the influent solids are 4% the removal efficiency is 98%.

$$\frac{40,000-800}{40,000} \times 100 = 98\%$$

It is important to remember that all solids handling processes create side stream flows that are returned to the head of the plant. These flows are high in BOD and suspended solids and usually have no dissolved oxygen. Tests for BOD and SS should be run on thickener overflow, or supernatant, and other solids handling side streams every shift. The suspended solids are again settled in the primary clarifiers, but the organics that are present are mostly dissolved. The secondary processes must deal with the majority of the BOD that is being returned. That BOD load should be included in any organic loading calculations like F:M ratios. Poor thickener performance can cause organic overloading in the secondary process.

### DISSOLVED AIR FLOTATION

Dissolved air flotation is a sludge thickening process that is used in activated sludge systems. The solids concentration in waste activated sludge (WAS) is only about 1/10 that of primary sludge. This means ten times as much water must be pumped for every pound of solids that is moved. The DAF process uses air to float solids to the surface of the tank instead of settling the sludge to the bottom. In order to float a sludge particle, it must have a specific gravity that is less than 1.0. The air bubbles that are formed in the DAF unit are trapped in the sludge particles and the particle becomes lighter than the water. Polymers are used to help trap the air. The floating sludge is then skimmed off of the surface of the tank. Solids concentrations can be increased to 2-4% solids. This reduces the volume of water needed to move each pound of solids to a little as 1/8 the original volume.

### Dissolved Air Flotation Unit

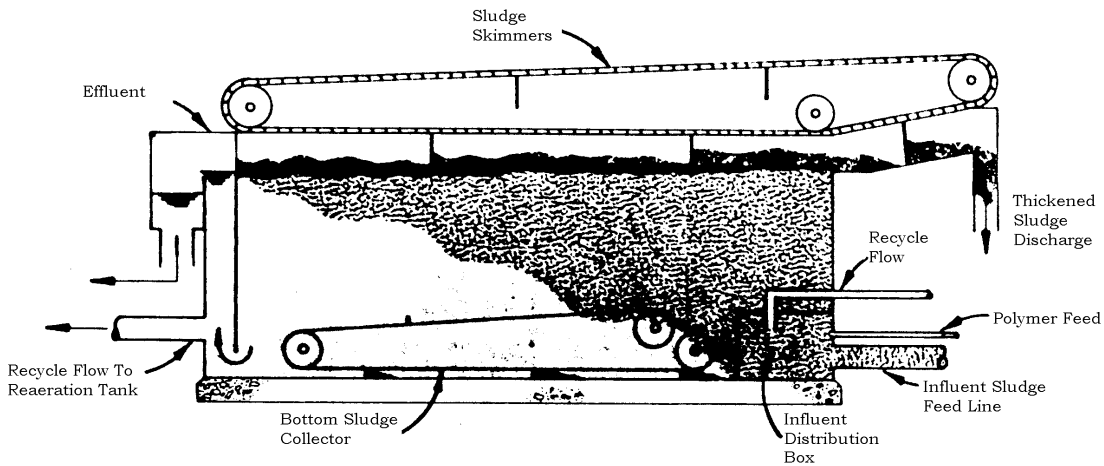

The DAF unit consists of a rectangular tank with skimmers that move on a chain drive on the surface and a chain drive sludge collector on the bottom. Skimmed sludge is removed from the front end of the unit and the sludge collector drags sludge to front of unit where it can be floated to the top. The effluent passes under baffles at the end of the tank and part of the flow is recycled back to the influent. The recycle flow is controlled by bleeder valve in the influent distribution box (bubble box). Before the recycle water is returned to the influent distribution box, it passes through a hydropneumatic tank that is charged with air.

DAF Unit Process Schematic

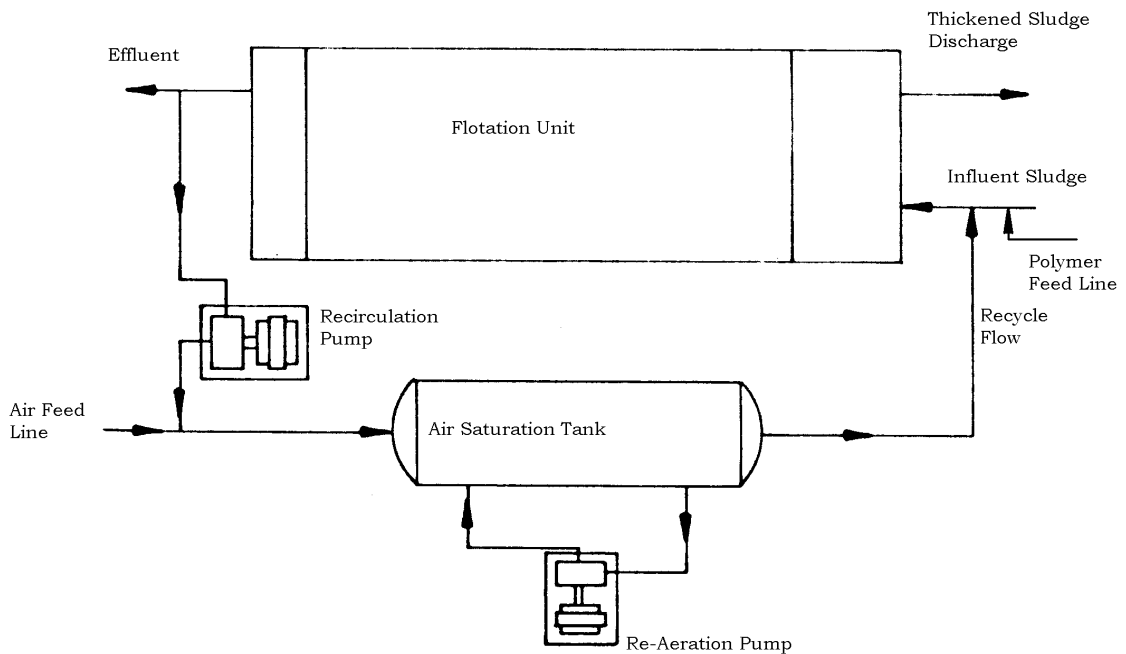

The bleeder or backpressure valve creates a line pressure of about 90 psi in the air tank. The recycle water picks up dissolved oxygen in the air saturation tank and, as it passes out of the bleeder valve into the DAF unit, the drop in pressure releases tiny air bubbles into the influent sludge flow. The same result happens if you shake up a can of soda and suddenly pop the top. Polymers are used also introduced into the influent sludge flow to aid in the formation of a large floatable sludge particle. Polymer dosing is determined by running a jar test to establish the minimum dosage needed to create a good sludge floc particle. The loss of recirculation flow or backpressure can result in a reduction of air bubbles and poor removal efficiency.

Process Control Variables for DAF Units

- Sludge Flow
- Air Flow
- Recirculation flow
- Recirculation Backpressure
- Skimmer speed
- Polymer dosage

A DAF unit may not run all of the time in smaller systems. During startup a DAF unit must be conditioned before sludge is added to the process. This is referred to as “charging” the unit. Water must be air saturated and recirculated while polymer is added for at least 30 minutes prior to sludge addition. Floc carryover in the effluent should only last for 20-30 minutes after the sludge is introduced. If floc carryover continues, jar tests should be run to check the polymer dosage. The air to solids ratio may also need to be adjusted to improve particle floatation. The skimmer speed is adjusted to improve the removal rate.

**OTHER SLUDGE THICKENING PROCESSES**

Vacuum filters, belt presses and centrifuges are also used to thicken sludge prior to final disposal or incineration. All of these processes utilize polymers to condition the sludge and aid in the separation process. Vacuum filters dewater the sludge by drawing a cake of sludge onto a belt drum and then sucking the water out of it.

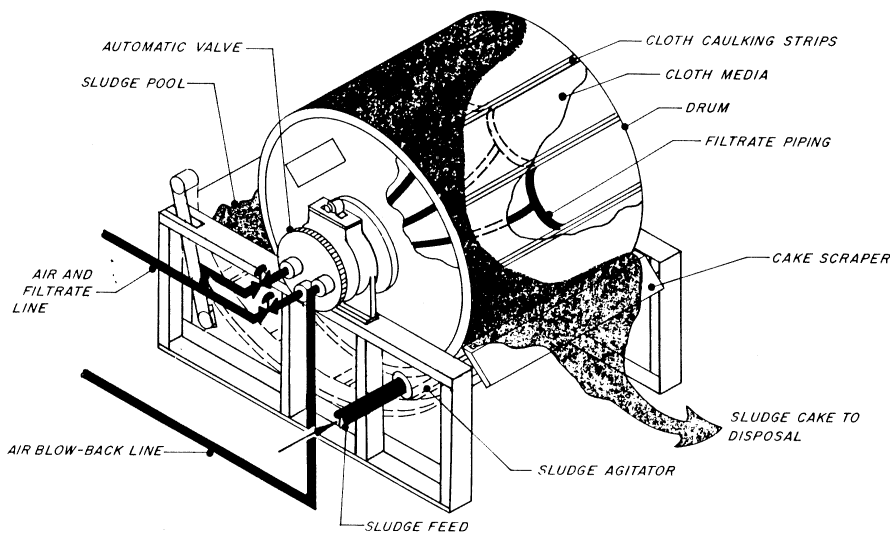

Vacuum Belt Filter

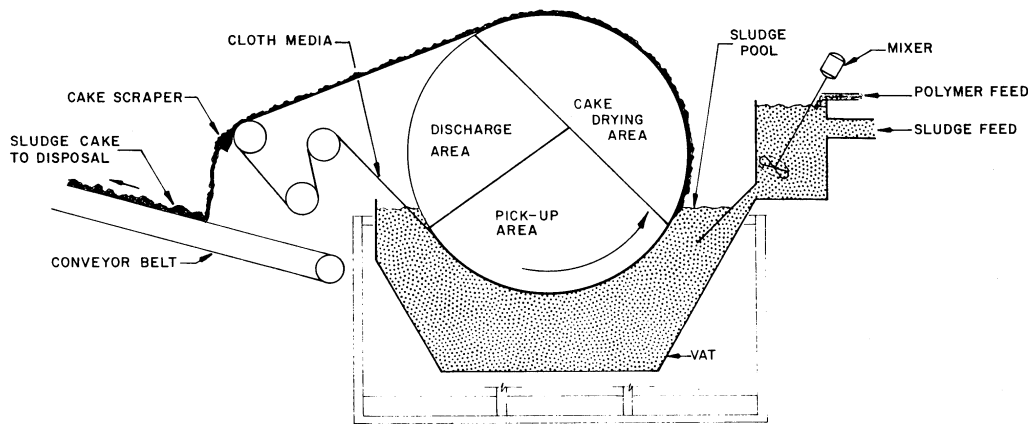

Vacuum Belt Filter Process Diagram

The filter belt rotates through a vat of conditioned sludge and the vacuum draws the sludge onto the belt. The sludge cake that is picked up on the belt moves out of the sludge vat and into the drying zone. The vacuum continues to draw air through the sludge cake to dewater it until the belt leaves the drum. The dewatered sludge cake is finally scraped off of the filter belt and carried by a conveyor to a disposal vehicle. A set of spray nozzles wash the belt as it returns to the drum. This process can produce solids in the 15-24% range, but the vacuum system uses a lot of energy.

Centrifuges spin the conditioned sludge and separate the solids from the water by centrifugal force. The spin cycle of a washing machine will also use centrifugal force to dewater your laundry.

There are two types of centrifuges. A batching centrifuge can only process a single load of sludge at a time. A scrolling centrifuge is designed to run with a continuous sludge flow.

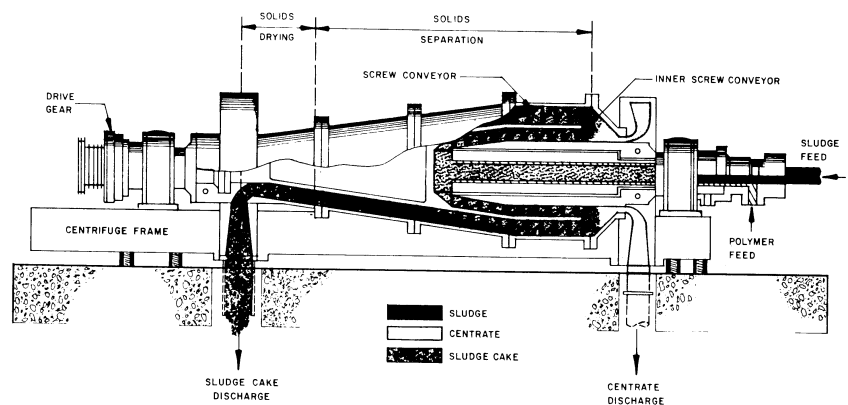

Scroll-type Horizontal Centrifuge

Conditioned sludge is fed into one end of the centrifuge drum. The solids are forced to the outside and a scrolling conveyor pushes them out one end of the unit. The water that is left behind, known as centrate, collects in the center and overflows to drain as a side stream.

A belt filter press is the most simple and least expensive means of mechanically dewatering sludge. Digested sludge is first sent to a conditioning tank that rotates like a clothes dryer drum. A polymer is added and, as clumps up, some of the water begins to drain from the sludge. The conditioned sludge is poured between two vinyl belts that travel through a series of roller drums. The water is literally squeezed out of the sludge. The sludge cake is then scraped from the belts and a set of spray nozzles are used to clean the belt. This creates another side stream that returns water to the head of the plant.

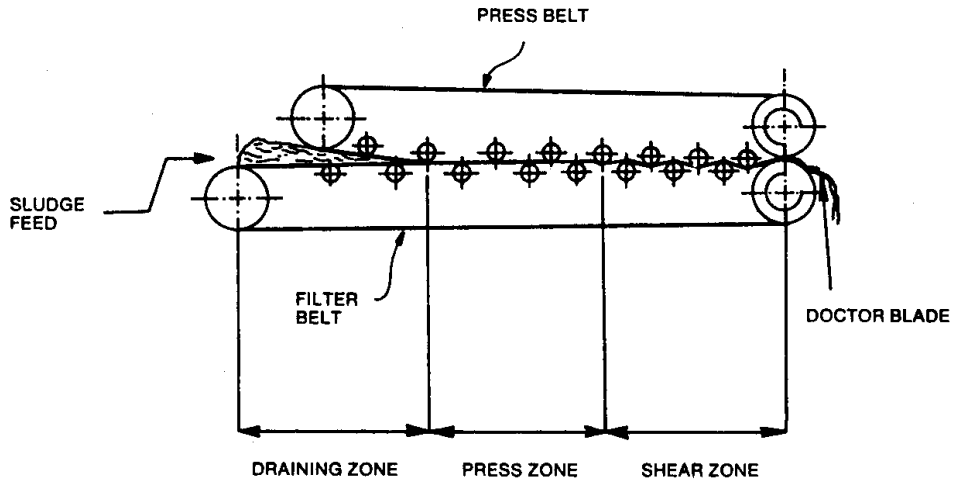

**Belt Filter Press**



**Belt Filter Press**  
**Conditioning drum on left**  
**Scraper blades on right**

### **BASIC STUDY QUESTIONS**

1. Gravity thickeners most closely resemble which other treatment process?
2. Why is thickening sludge important to digester operations?
3. What are other processes are used to thicken sludges?

### **BASIC SAMPLE TEST QUESTIONS**

1. The vertical pickets on a gravity thickener:
  - A. Reduce the surface loading rate
  - B. Aid in mixing and gas release
  - C. Increase supernatant BOD
  - D. None of the above
2. The sludge blanket in a gravity thickener should be:
  - A. 1-2 feet deep
  - B. 3-4 feet deep
  - C. 5-8 feet deep
  - D. 10-12 feet deep
3. As the sludge blanket depth increases:
  - A. Detention time increases
  - B. Detention time decreases
  - C. Weir overflow rate decreases

### **ADVANCED STUDY QUESTIONS**

1. Why is the removal efficiency of a gravity thickener important?
2. What are operational parameters for a gravity thickener?

3. How is a polymer dosage determined for a DAF unit?
4. What does the term charging a DAF unit mean?

### **ADVANCED SAMPLE TEST QUESTIONS**

1. Which of the following is not an operational control for a DAF unit?
  - A. Sludge Flow
  - B. Recycle Rate
  - C. pH
  - D. Skimmer speed
2. The detention time in a gravity thickener should be:
  - A. 1-3 hours
  - B. 4-6 hours
  - C. 10-12 hours
  - D. 1-2 days
3. Poor removal efficiencies in a gravity thickener will result in overloading the:
  - A. Pretreatment processes
  - B. Primary treatment process
  - C. Secondary treatment process
  - D. Tertiary treatment process
4. Which type of sludge is most difficult to de-water?
  - A. Primary sludge
  - B. Trickling filter sludge
  - C. Waste activated sludge
  - D. Septic sludge



## DIGESTERS

Sludge digestion is the primary means of stabilizing the volatile organic material in the sludge. Biologically degradable organics account for 60-65% of the total solids in the sludge. The organic sludge has water molecules bound within it. Digestion releases most of the bound water in the sludge. As the sludge decomposes the organic material is converted into gases. This results in a reduction in the volume of sludge that will ultimately have to be landfilled, land applied, or composted. Anaerobic digestion will produce carbon dioxide (CO<sub>2</sub>), methane (CH<sub>4</sub>) and hydrogen sulfide (H<sub>2</sub>S). Carbon dioxide is the only gas that is produced in aerobic digesters.

### ANAEROBIC DIGESTION

Anaerobic digestion must occur in the absence of dissolved oxygen. But the bacteria that digest the organics in the sludge still need oxygen to live. They use oxygen that is chemically bound in organic compounds like sugars and starches. The gases that are produced from this process are present in different ratios depending on the operating temperature and ratio of volatile acids to alkalinity in the digester. There are two groups of bacteria involved in anaerobic decomposition. One group is called acid formers. They take complex raw organic compounds, like sugars and starches, and break them down into organic acids and release some carbon dioxide in the process. The second group of bacteria takes the organic acids from the acid formers and converts them into methane. They are called the methane fermenters. Methane fermenters will not work if the pH is less than 6.6 or greater than 7.6. They work best when the pH is 7.0-7.2.

Since the acids that are being produced in the first part of the process will lower the pH, it is important to maintain enough alkalinity in the digester to buffer the effect of the acids. This is necessary to keep the pH above 7.0 and maintain maximum methane production. Running volatile acids and alkalinity tests on the digester is an important part of efficient digester operations. The acid/alkalinity ratio will change before the pH begins to drop. If the acids increase and drive the ratio out of the normal operating range, the digester may become upset. The volatile acid to alkalinity ratio should be kept below 0.4 and the alkalinity should not fall below 1000 mg/l.

Using the pH as the control parameter is not a good idea. By the time the pH drops it may be too late to avoid the upset. When this happens, the methane production will drop dramatically and foaming may occur. Most of us have had a case of heartburn or indigestion before; it's basically the same thing. Losing methane production can compound the problem, if methane is used to heat the digester.

## TEMPERATURE RANGES FOR ANAEROBIC DIGESTION

There are three groups of anaerobic bacteria that can be found in wastewater anaerobic digesters. Each group is temperature sensitive and can only survive in a very narrow temperature range. The temperature of an anaerobic digester must never be changed more than 1°F per day. Foaming and upsets will occur when the temperature rises or falls too quickly.

Psychrophilic (cold-loving) anaerobic bacteria operate in a range from 50-68°F. They are found in unheated Imhoff tank digesters and septic tanks. They are not efficient. It takes from 50-120 days to stabilize the sludge. The gases that are generated contain very little methane and are high in hydrogen sulfide. Odor problems are always associated with this process since there is no gas collection.

Mesophilic (medium temperature loving) bacteria operate in a range from 68-113°F. Optimum temperatures are from 85-100°F and most digesters operate at 95-98°F. At that temperature it normally takes 25-30 days to digest the sludge. When operating efficiently at this temperature, digesters will produce 8-12 cubic feet of digester gas for every pound of organics. The gas should be 65-70% methane and 30% carbon dioxide. It will have a heat value of 500-800 BTU's per cubic foot.

Thermophilic (heat-loving) bacteria have an operating temperature range of 120-135°F. Most thermophilic digesters are heated to 124-126°F. Larger percentages of methane are produced at these temperatures, but the higher temperature also requires more energy to heat the system and negates any advantage from the increase. Sludge can be digested in 5-12 days, cutting the number of digesters needed in half. These bacteria are very sensitive to temperature changes and are easily upset. There is another issue regarding heating a digester to these temperatures. When heat exchangers or heating coil temperature approach 130°F, sludge begins to cake on the piping. This clogs the heat exchangers and insulates the heating coils.

## ANAEROBIC DIGESTERS

Anaerobic digesters are sized based on a solids loading rate of 0.15-0.35lbs per day/cuft. Anaerobic systems are usually built with two digesters in series. The primary digester receives the thickened raw sludge. It is heated and is equipped with mixing equipment to keep the sludge stirred and temperatures uniform. The mixers can be mechanical units or gas bubble mixers that mix by pumping digester gas into the sludge. A heat exchanger system will also assist in mixing the contents of the digester as sludge is pumped through the exchanger. The treated sludge is drawn from the secondary digester.



**Primary digester with mechanical mixers**

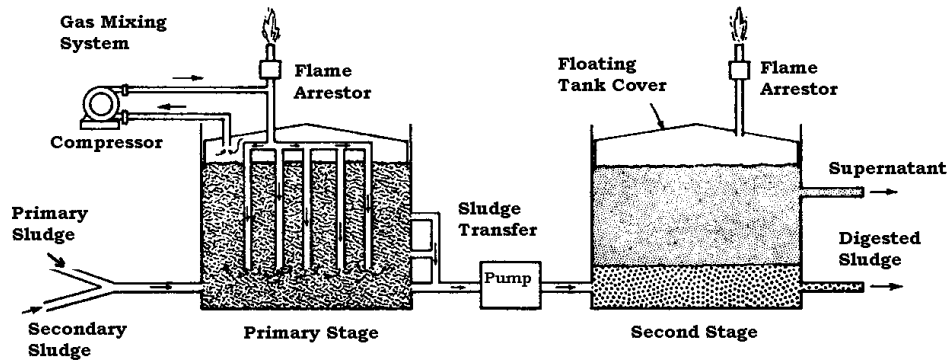

## Two Stage Anaerobic Digester

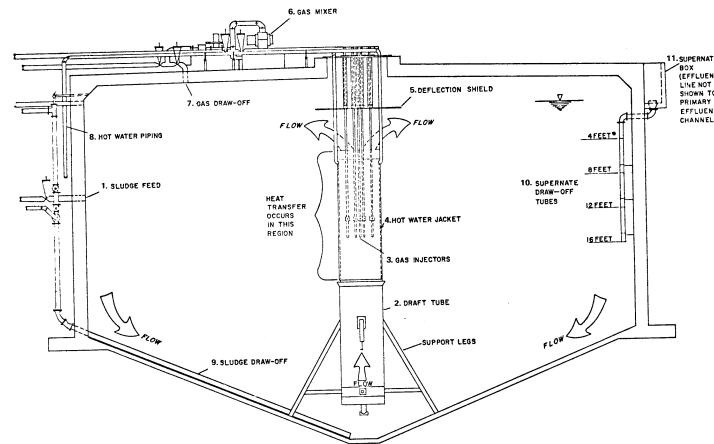

**Primary Digester**

The secondary digester may or may not be mixed. It is used to finish the digestion process. The digested sludge is drawn off to drying beds or thickened using mechanical processes. The overflow from the secondary digester is returned to the head of the plant. With no DO and a high BOD strength, this flow can have a dramatic impact on the secondary processes. The BOD strength and flow must be known so that it can be added to the calculation for secondary organic loading. Secondary digesters also store most of the digester gas that is produced. They can have a floating top that rises and falls with changes in the digester level and gas production or removal.



**Secondary Digester with Floating Cover**

A water seal around the edge of the floating top prevents gas from escaping. It is designed to maintain about 8-12 inches of water in the seal. The gas pressure in the system must be kept at less than 8 inches of water column to prevent the water seal from blowing out. If the gas is not removed fast enough, the pressure will rise and threaten the integrity of the water seal.

If too much sludge is removed and a vacuum is created, the vacuum breaker will open and let air into the digester. This will prevent the floating cover from collapsing. But the introduction of air into the digester can create explosive conditions. Great care must be taken to maintain the water seal on the floating cover.

**Pressure Relief Valve – Top  
Vacuum Relief Valve – Middle  
Flame Arrester - Bottom**



## GAS HANDLING SYSTEMS

The danger of explosion is always present when flammable gases are being handled. No smoking or sparks can be allowed in the gas handling areas. Most systems require the use of brass tools and boot covers to minimize the potential for sparks. Digester gas is often used to heat the digesters and it can also be used in co-generation operations. A co-generation process uses the digester gas to power electrical generators that can supply electrical power to the plant. The cooling water for the gas engines is then used to heat the digesters.

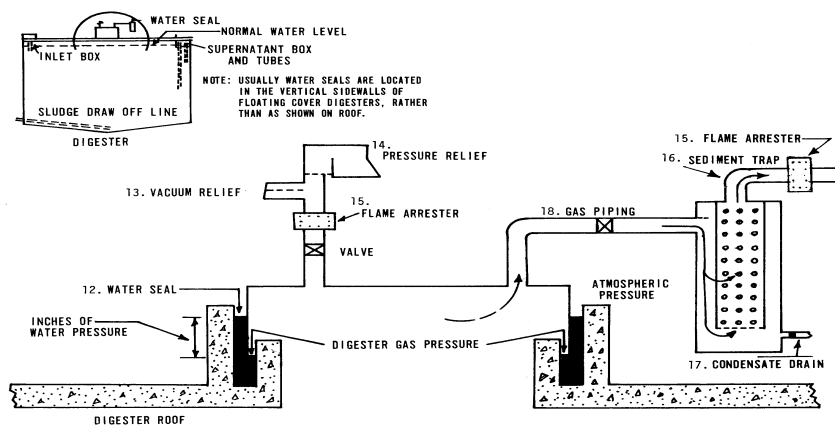

When digester gas is used for co-generation it must be processed before it can be sent to the gas engines. Dryers or refrigeration units are needed to remove the moisture in the gas. Condensation is a problem in the gas transfer system. Condensate traps are installed in the system prior to drying. These traps collect water that condenses in the piping. They must be manually drained at least once a day. Carbon dioxide can be stripped out using a limestone absorption process.

Several safety devices are used to protect the gas system. They include flame arrestors, pressure and vacuum relief valves, and thermal shutoff valves. A flame arrestor has a set of baffles that are designed stop the spread of flame in the piping. The baffles can get clogged over time and must be inspected and serviced every three months. A thermal shutoff valve has a fusible rod that holds a valve disk in the open position. When a flame generates enough heat, the fusible rod melts and the valve seat drops to shut off the gas flow.

### **SLUDGE FEED AND REMOVAL**

The sludge that is pumped to the digester is at least 30°F colder than the digester. It can lower the digester temperature if it is added in large volumes over short periods. The best practice is to feed at least twice a shift at low flow rates so that the heating systems can maintain a more constant temperature. Feeding at lower flows for longer periods will also help minimize the organic impact on the digester. A sudden surge of BOD can create an imbalance in the volatile acid/alkalinity ratio. Thickening sludge to achieve the highest solids content possible will also minimize the impact on the digester temperature. Thicker sludge means less water is required to move a pound of solids.

Don't forget that the secondary digester overflows as the sludge is added to the primary unit. This supernate is returned to the head of the plant. Returning this effluent at high rates on an intermittent basis can result in shock BOD loads on the secondary. If there is no secondary digester, the mixers should be shut down for an hour prior to each pumping cycle.

Removing sludge from the secondary digester too fast can create an upset condition. Since secondary digesters are usually not mixed, the sludge at the bottom of the digester will be the most stable. It contains organisms that work on the more unstable "green" sludge that settles as it enters from the primary digester. If too much settled sludge is removed, the population of these organisms may drop to the point that an upset occurs. Well-digested sludge will have a pH between 7.0-7.2. It will not have the septic odors of green sludge and will have a leathery appearance. Green sludges also take a much longer time to dry because much of the cellular bound water isn't released as it is in well-digested sludge.

## **DIGESTER UPSETS**

Digesters get "heartburn" for a number of reasons. If the temperature drops it can shock the methane fermenting bacteria and they will stop working. The volatile acid/alkalinity ratio will increase and the pH will drop. If the temperature is brought back up too quickly it can further shock the bio-system. Never raise or lower digester temperatures by more than 1 degree F per day. A sudden increase in solids loading can also cause an upset. The methane formers will not be able to keep up with the acid production and the VA/Alkalinity ratio will increase. The best thing to do in this case is the same thing you would do if you had acid indigestion, stop eating and rest. If that didn't work you might take some antacids tablet to neutralize the stomach acids. That is the same thing that needs to happen to recover from a digester upset. Rest the unit by not pumping any new sludge for at least 24 hours. If that isn't possible, adding calcium carbonate or calcium hydroxide to the sludge flow will increase the alkalinity and help restore the VA/Alkalinity ratio.

## **AEROBIC DIGESTERS**

Aerobic digesters resemble an extended aeration activated sludge process. Waste activated sludge and trickling filter humus can be mixed with primary sludge and sent to the digester for further decomposition. The aerobic digester acts like an extended aeration plant in that it retains the solids until nearly all of the volatile solids have been stabilized. These digesters are also built with multiple tanks or stages. They are 18-20 feet deep and are aerated by diffuser headers. A DO level of 1-2 mg/l must be maintained. The pH should be between 6.8-7.4.

In order to achieve proper digestion without offensive odors, the organisms that are involved must be kept at their highest level of metabolism. This is known as endogenous respiration and it means the bugs at operating their peak efficiency. The digestion process may take from 25 to 45 days. If the sludge is to be applied to land it must be kept under aeration for at least 45 days. When sludge is wasted to the digesters the overflow is returned to the head of the plant. While this flow is easier to treat than the side stream from an anaerobic digester, it may still have a high organic strength. The aerators should be shut down for 30-60 minutes prior to wasting. Shutting off the air will allow settling to occur and will result in lower solids in the supernate.

## **SLUDGE DRYING BEDS**

Sludge that is drawn from the digester is often placed in sludge drying beds. These beds are shallow rectangular basins with a sand bed and underdrain system. Sludge is placed on the bed in 10-12 inch pours. It dries by evaporation and gravity separation of the water. After the sludge is poured onto the bed, the underdrain valve is opened to allow the water that drains out of the bed to return to the head off the plant. The length of time it takes to dry the sludge will depend on the condition of the sludge and degree of digestion. Seasonal temperature differences and compaction of the sand bed can also affect drying times. Never put digester sludge in a drying bed that already has dry sludge in it. Drying beds with asphalt bases make it easier to remove dried sludge with heavy equipment.

The dried sludge is removed and taken to a landfill, composted, or land applied on an approved disposal site. If it is to be applied to public grounds it must be heat treated in a flash furnace or composted. A temperature of 140°F must be maintained for at least 14 days if the compost is going to be applied to public lands.

### BASIC STUDY QUESTIONS

1. What three gases are produced in anaerobic digesters?
2. What are the characteristics of well-digested sludge?
3. How deep should the digested sludge on the drying bed be?
4. Which of the following statements is true regarding pumping sludge to a digester?
  - A. The solids concentration should be as high as possible.
  - B. Pumping smaller volumes more often is easier on the process than pumping lots of sludge all at once.
  - C. The overflow from the digester will return to the headworks of the plant.
  - D. All of the above.

### BASIC SAMPLE TEST QUESTIONS

1. Most digesters operate at which temperature range?
  - A. 60-75° F
  - B. 80-85° F
  - C. 95-98° F
  - D. 120-135° F
2. When operating properly a medium range digester will produce gas that is \_\_\_\_\_ methane.
  - A. 30%
  - B. 70%
  - C. 90%
  - D. 100%
3. The pH of well-digested sludge should be:
  - A. 5.0-5.8
  - B. 6.0-6.5
  - C. 7.0-7.2
  - D. 8.0-9.0

### ADVANCED STUDY QUESTIONS

1. How long does it take to stabilize sludge at the three temperature ranges for anaerobic digestors?
2. What is the solids loading rate for an anaerobic digester?
3. Why is it important to concentrate sludge?
4. Why is the volatile acid-to-alkalinity ratio important in digester operations?
5. What is meant by endogenous respiration?

**ADVANCED SAMPLE TEST  
QUESTIONS**

1. What is the BTU value of digester gas?
  - A. 100-200 BTU's/cuft
  - B. 500-800 BTU's/cuft
  - C. 900-1600 BTU's/cuft
  - D. 1500-2300 BTU's/cuft
2. The optimum temperature for the mesophilic range is:
  - A. 65-68 degrees F
  - B. 70-75 degrees F
  - C. 95-98 degrees F
  - D. 113-125 degrees F
3. Sludge will cake on the heating coils if the water temperature exceeds.
  - A. 68 degrees F
  - B. 105 degrees F
  - C. 130 degrees F
  - D. 150 degrees F
4. Flame arrestor baffles should be cleaned every:
  - A. 3 months
  - B. 6 months
  - C. Year
  - D. Two years
5. The pH of an aerobic digester should be:
  - A. 3-5
  - B. 5.6-6.2
  - C. 6.8-7.4
  - D. 8.0-8.3

## LAGOONS AND STABILIZATION PONDS

One of the oldest means of treating wastewater is the wastewater lagoon or stabilization pond. Although the terms are usually interchangeable, the term lagoon usually refers to an impoundment that receives raw sewage. A stabilization pond is a lagoon that receives primary effluent and acts only as a secondary treatment process. Stabilization ponds can also be used to treat secondary trickling filter effluent. If this is the case, the pond is a tertiary treatment process and is called a polishing pond. All of these lagoon systems utilize bacteriological waste stabilization and long detention times to decompose the organic wastes. The long detention times also result in pathogen reduction. Ponds and lagoons can be mechanically aerated, but most are not aerated and rely on the natural oxygen transfer from wind and the symbiotic relationship between the colony of bacteria and the algae in pond. Algae are small water plants that grow in the lagoon. They provide most of the dissolved oxygen needed to maintain aerobic conditions and avoid odors caused by anaerobic or septic conditions.

There are several advantages associated with lagoon operations. Lagoons are cheap to build. They do not incorporate a lot of equipment, so maintenance and electrical costs are low. They do not require highly trained operational personnel. They provide treatment that can be equal to some secondary treatment processes and have fewer sludge handling issues. There are also disadvantages to lagoon systems. They take up a lot of land. The effluent quality varies with seasonal temperature changes and may have suspended solids levels that can create regulatory problems. System upsets almost always result in odor problems and recovery times may be weeks or months.

### TYPES OF LAGOONS

Lagoons and stabilization ponds are classified by the type of bacteria that are responsible for the decomposition process. The main difference in most cases is the depth of the pond.

**Anaerobic lagoons** are 10-14 feet deep. Anaerobic bacteria to break down the organic waste. This results in septic conditions in the lagoon and odors associated with septic sewer gases particularly hydrogen sulfide and its rotten egg odor. Most of the decomposition is accomplished by acid forming bacteria. The pH in these lagoons is usually below 6.5. Anaerobic lagoons are sometimes used as sludge impoundments. They are total retention and do not have an effluent discharge. These ponds are normally used to store and treat industrial wastes from food processing or meat packing operations. They are sometimes used as sludge ponds for RV dump sites at recreational facilities.

**Facultative lagoons** have an operating depth of 4-7 feet deep. Facultative bacteria are responsible for most of the treatment that occurs in these ponds. They are the most common type of lagoon system. Suspended solids settle to the bottom of the pond where there is less dissolved oxygen. The facultative bacteria will become anaerobic to digest these solids. Circulation in the pond will eventually bring these bacteria to the surface where high levels of dissolved oxygen exist. When this occurs, the bacteria will become aerobic to stabilize the dissolved organics that are present.

Odors from these types of lagoons are normally not objectionable. As the hydrogen sulfide, generated in the anaerobic zone, rises to the surface the dissolved oxygen present oxidizes it into sulfates that do not cause odors. The algae that grow in the lagoon are critical to the successful stabilization of the organic load. They supply 70-80% of the oxygen that the bacteria will need. The rest of the oxygen comes from wind and wave action on the surface. The aerobic decomposition in the upper zone results in the uptake of dissolved oxygen and the release of carbon dioxide (CO<sub>2</sub>). The algae will take in carbon dioxide (CO<sub>2</sub>) and, through photosynthesis, use it to create sugars and release dissolved oxygen (O<sub>2</sub>) that is used by the aerobic bacteria.

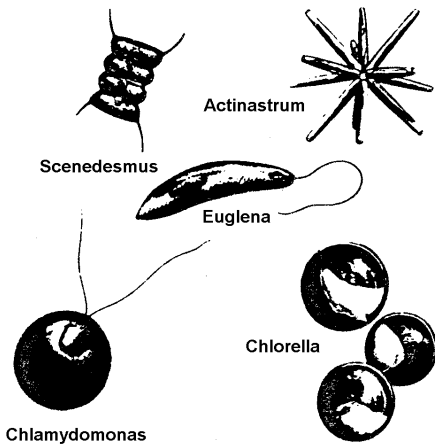

**Algae Found in Lagoons**

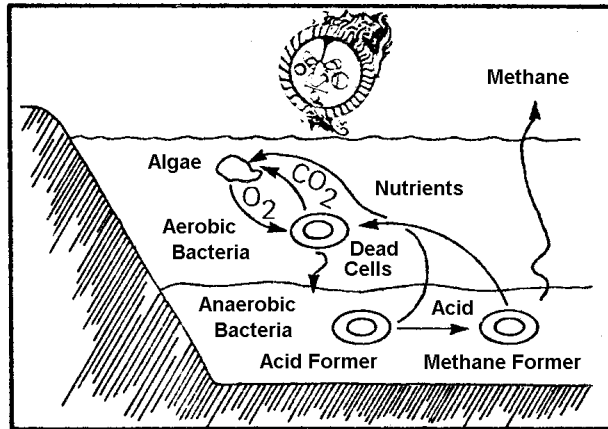

**Facultative Lagoon Bioactivity**

**Aerobic** lagoons are very shallow. They are only about 3 feet deep. They are most often the final cells in a multi-staged lagoon system. They are also used as polishing ponds for tertiary treatment of trickling filter plant effluent. Their shallow depth allows sunlight to penetrate to the bottom of the pond to encourage algae growth and aerobic conditions throughout the pond. The low solids loadings found in these tertiary treatment applications means that these ponds normally have no sludge zone. These ponds may also be mechanically aerated. The ultraviolet radiation from sunlight penetration can also help kill pathogens that may be present.

## LAGOON SYSTEM DESIGN

Lagoons can be single pond operations or they can be constructed using several ponds in series. The ponds are rectangular with bermed dikes to contain the wastewater. The dikes must be sloped and crowned to allow runoff from rain to run down the sides evenly. Improper grading of the dike can result in channeling the runoff, which can cause serious erosion problems. Dikes should be planted with native grasses or riprapped with rock to stabilize the soil and help prevent erosion.

In areas where ponds are constructed in clay soils there may be little groundwater infiltration from the pond. But in other types of soils, water that leaks out of the lagoon and into the groundwater supply is a serious issue. Aquifer protection regulations may require the drilling of sampling wells to monitor the groundwater around the ponds. The main concern is usually nitrate contamination. Ponds built in other types of soils may have to be lined with plastic or rubber liners. Lime and bentonite clay may also be incorporated into the soil to seal the bottom of the pond in some cases.

All pond systems should have an influent flow meter and a barscreen for pretreatment. Pond inlets should be designed to spread the flow evenly across the pond. This is done to prevent short-circuiting and make suspended solids distribution more even. If there is no primary treatment, inlet piping to the first stage should extend out into the pond far enough that settled solids will not build up around the edge of the pond where they can create odor problems.

Influent piping is sometimes designed to allow the ponds to be set up in parallel. This type of piping scenario can also be used to create a step feed flow pattern that sends some of the raw flow to the primary cell and the rest of the flow to the secondary cell. The primary effluent would then also flow to the secondary pond. This moves some of the BOD loading from the first cell and distributes it through more of the process to help avoid organic overloading.

### Ponds in Series

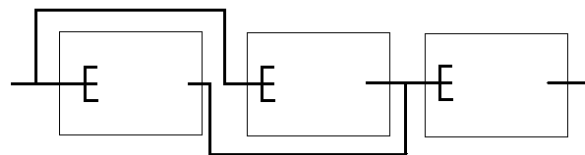
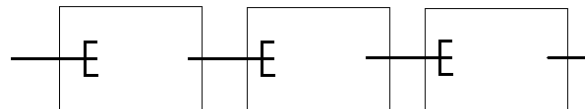

### Ponds in Parallel

The effluent structure should be designed to minimize the amount of algae in the discharge. Algae increase the suspended solids in the effluent. A baffle is placed around the effluent pipe to help keep floating algae out of the effluent stream. Baffling is not very effective during high flow or in the summer when algae concentrations are highest. The SS issue related to algae is one of the biggest drawbacks to lagoon systems. Effluent structures should also be designed to control the water level in the lagoon. The effluent structure may have an adjustable weir made of planks placed in a slotted opening. The planks or flash boards can be inserted or removed to change the overflow level and the level in the lagoon. Levels may also be controlled using a series of effluent valves set at different depths or by simply pumping it down by increasing irrigation application rates.

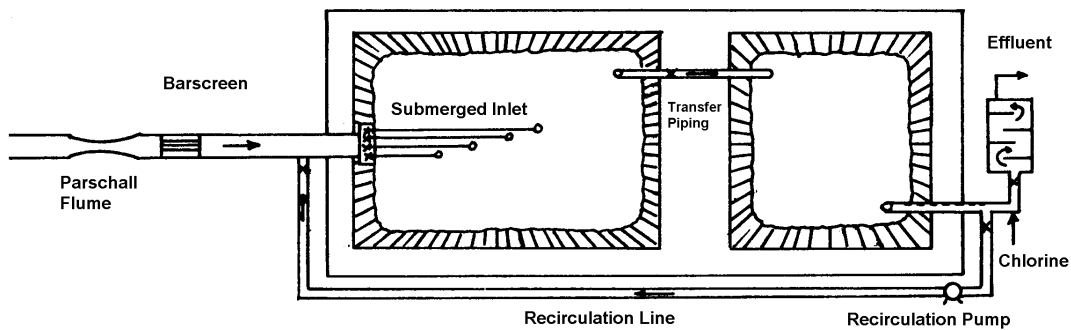

**Two Stage Lagoon System With Recirculation**

Transfer lines carry water from one pond to another. Recirculation is sometimes used in multi-staged lagoon systems. Water from the last cell is pumped back to the inlet of one or more of the upstream cells. The purpose of recirculation is to bring the water with higher algae and DO content up to the front of the process where the BOD loadings are the highest. It also reduces the detention time in each stage. Recirculation also moves the organic load into the secondary cells faster to spread the BOD loading more evenly throughout the process. The combination of recirculation and step feed capabilities provides the maximum amount of operational control available in non-aerated lagoon systems. The effluent outfall to the receiving stream should be submerged to minimize foaming problems.

### **CHANGING THE WATER LEVEL**

When the water level in the pond needs to be raised it is a simple matter to add another piece of planking or flash board to the effluent weir slot in the outlet structure. This will raise the level by the thickness of the board. The discharge will effectively stop until the water level in the pond rises to the new overflow height. If a valving system is used, all of the effluent valves are closed to isolate the system. This will allow the pond to retain flow during the winter months, when bioactivity is down, if the lagoon has adequate capacity. If the pond is empty it should be filled to at least 1 foot deep with clean water, or treated effluent, before raw sewage is added. It will take 5-12 days for the algae population to grow to the point that the lagoon returns to its normal green color. Recirculation pumping can be used to do this in a case where the pond was drained for maintenance.

Lowering the water level is a little trickier. In late fall some systems lower the water level so that they can maximize their winter retention time. The problem with simply removing a board from the weir slot is that the water will leave the pond much too quickly. This can result in drawing sludge off the bottom of the pond, which can result in an upset. Before the board is removed the outlet valve must be throttled to control the discharge. When the downstream half of the outlet box floods the boards they can be removed. The outlet valve is then opened until the flow is 150-200% of the daily average. This will allow the pond level to drop gradually without upsetting the system.

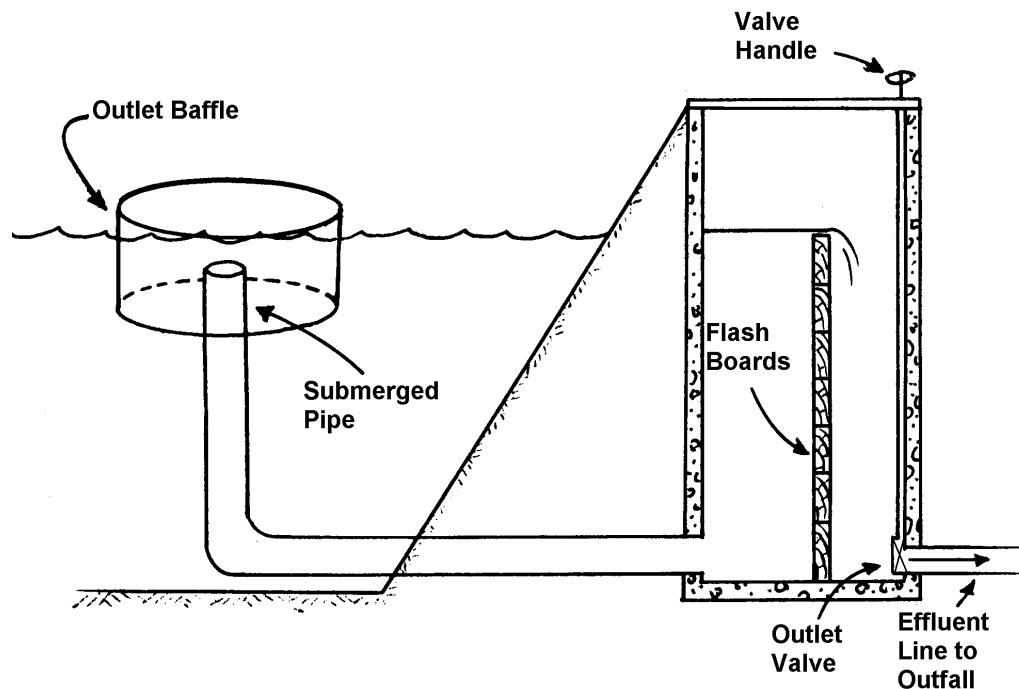

**Lagoon Effluent Structure**

## **BIOLOGY AND CHEMISTRY OF LAGOONS**

Biological activity and organic removal efficiency of a stabilization pond can be impacted by changes in loading, temperature, or pH. Increased organic loading can result in anaerobic conditions that will create an upset in the primary cell of the system. Organic overload can also be caused by a reduction in the bioactivity in the pond when the temperature drops. This is a problem in the winter. When the water temperature drops to 50°F bioactivity comes to a virtual standstill. This is actually a good thing because the algae also die when the temperature drops. If the bacteria were still active, the anaerobic decomposition would cause odors all winter. Reducing the loading on the primary cell by diverting raw flow to the secondary ponds by step feed or parallel operation can reduce the loading on the primary cell. Increasing recirculation can also help recover from an organic upset.

When sunlight hits the algae in the lagoon, photosynthesis takes place. The algae take in carbon dioxide and give off dissolved oxygen. The carbon dioxide reacts with water to form carbonic acid.



Carbonic acid will lower the pH. As the algae absorb the carbon dioxide they help buffer the pH of the lagoon. So the bioactivity of the algae will cause a fluctuation in the pH of the lagoon over the course of a day. During the day the pH should slowly rise from 6.8-7.0 to about 7.2-7.6.

Since there is no photosynthesis and no subsequent removal of carbon dioxide at night, the pH of the lagoon will slowly drop back to 6.8-7.0. The lowest pH will be just before dawn. If the lagoon is overloaded, the pH will drop below 6.8 because the algae can't use up the carbon dioxide as fast as the bacteria release it. The dissolved oxygen levels will also be at their lowest just before dawn because the algae aren't releasing oxygen at night.

## **LOADING AND DETENTION TIMES**

Facultative ponds are designed for a BOD loading rate of 20-35 pounds per acre per day. Aerobic polishing ponds are designed for 15-20 pounds/acre/day. Aerated lagoons can handle BOD loading of up to 50 pounds/acre/day. Detention times for facultative lagoons range from 30-60 days. Detention times for aerobic polishing ponds may be as little as 10-20 days. Raising or lowering the lagoon level can change detention times. Facultative lagoon levels should always maintain at least 4 feet of water in the pond. Aerobic lagoon levels should always maintain at least 18 inches of water in the pond.

## **LAGOON SYSTEM MAINTENANCE**

Most of the maintenance issues for lagoons are related to groundskeeping. Dikes must be mowed regularly. Aquatic plants and weeds must be removed from the water. Cattails and other aquatic reeds will create stagnant areas along the edge of the pond. Their deep roots can also damage liners and seals. The stagnant water is a breeding ground for mosquitoes and the lack of circulation can result in anaerobic conditions developing that can cause serious odor problems.

Rodents like muskrats and prairie dogs can burrow into the dike and cause structural damage. They should be trapped and removed. Repairs to the dike should be done immediately. Trees and shrubs should be removed from around the lagoon to keep them from blocking the wind and reducing surface oxygen transfer. Mechanical mixers should be checked and lubricated according to manufacturer's instructions. Sludge buildup is another problem in many older lagoon systems. The first cell receives most of the suspended solids. When the sludge level increases over time it will reduce the effective water depth and create channeling that can reduce detention times dramatically. If a lagoon cell is taken out of service it should always retain about a foot of water to hold the liner down and prevent wind damage.

## ODOR CONTROL

Odors in lagoons are usually caused by septic conditions resulting from organic overloading. In late summer blue-green algae blooms can also cause odors that smell like dead fish. Duckweed is a floating aquatic plant that can block the sunlight, which reduces the activity of the algae and results in lower DO levels. Maintaining good wind action will help control duckweed. The best way to deal with this problem in a multi-cell system is to recirculate and bring more dissolved oxygen from the back of the process to the front cell.



**Duckweed and the blue-green color are indicators of pending odor problems.**

Sodium nitrate can be applied at a rate of 50 lbs/acre/week to help recover faster from an odor-causing upset. The nitrate ( $\text{NO}_3$ ) will provide a source of chemically bound oxygen that the bacteria can use for anaerobic decomposition. If the bacteria use the oxygen from the nitrates instead of sulfates less hydrogen sulfide will be produced.

## OBSERVATIONS AND OPERATIONAL TESTING

When a lagoon is operating properly, the algae will have a dark green appearance. When things go wrong the color of the lagoon will change. The lagoon should be checked on a daily basis so that corrective measures can be implemented quickly. Organic overloads caused by food processing plants and dairy farms will create a pale milky gray color. Blue green algae blooms cause dark turquoise-green colors. These blooms begin around the edge of the pond and spread out into the center. Toxic upsets from industrial discharges such as metal plating or chemical production can cause a wide range of very colorful conditions in the lagoon. Floating solids rising to the surface of the pond indicate septic sludge conditions. This is usually caused by a pH below 6.5, low DO, and low nitrogen concentrations.

Operational tests for lagoons should include pH, temperature, DO, BOD and TSS for both influent and effluent. It is important to know the influent and the effluent flow because they are not the same. Evaporation and infiltration can result in losses of as much as 1 inch per day during the summer months in the Southwest. This amounts to about 27,000 gallons per acre. If the pond level is being lowered, the effluent flow may be twice the daily influent flow. The influent flow is needed for plant loading and the effluent flow is used to calculate pounds of BOD and TSS to the stream for the monthly discharge monitoring report (DMR).

### BASIC STUDY QUESTIONS

1. What is the most common type of lagoon system?
2. Where does the DO come from in a facultative pond?
3. What is the difference between running cells in series or parallel?
4. What happens to bioactivity in during the winter months?
5. Floating solids in the primary cell of a facultative lagoon system may mean:
  - A. Septic conditions from overloading
  - B. The lagoon is operating normally
  - C. It is hydraulically under loaded
  - D. Poor dike maintenance
6. What can be done to recover from an organic overload on a pond?
  - A. Increase recirculation
  - B. Run ponds in parallel
  - C. Add sodium nitrate
  - D. All of the above

### BASIC SAMPLE TEST QUESTIONS

1. The detention time for an aerobic lagoon system should be?
  - A. 3-5 days
  - B. 10-20 days
  - C. 30-60 days
  - D. 200-300 days
2. What is the depth of a facultative pond?
  - A. 1.5-3 feet
  - B. 4-7 feet
  - C. 10-14 feet
3. Lagoon levels should be lowered:
  - A. During the winter
  - B. In late summer and early fall
  - C. Each spring
  - D. Always keep them the same depth
4. Why does the pH drop at night?
  - A. The bugs get tired
  - B. There is no photosynthesis at night
  - C. BOD loadings are higher at night
  - D. There's too much DO at night
7. Cattails in a lagoon are a problem because:
  - A. They can damage the liner
  - B. They harbor mosquitoes
  - C. They create stagnant water, which causes odors
  - D. All of the above

## SECONDARY TREATMENT – FIXED MEDIA

The first secondary treatment processes were trickling filters. They are the original fixed media processes. Trickling filters have been in use for almost 100 years. The other members of the fixed media family include high rate trickling filters and rotating biological contactors (RBC) and packed bed filters (PBF). Standard rate trickling filters and high rate trickling filters are very similar in construction. They both contain a media that provides a surface for living microorganisms to grow. A distribution arm rotates over the top of the media showering the primary clarifier effluent over the media. The flow passes over the media and is collected in an underdrain system at the bottom of the tank. The trickling filter effluent then goes to the secondary clarifier.

Standard rate trickling filters use a bed of rocks as the filter media. High rate filters usually use a plastic media or redwood slats. High rate filters also are much taller than standard filters. A conventional trickling filter is only about 6-8 feet deep. A high rate trickling filter may be 20-25 feet high. The plastic media has more surface area than the rocks in a standard unit. This means that higher hydraulic and organic loadings are possible on a high rate unit.

High rate filters are also called bio-roughing filters. They are inserted upstream of conventional activated sludge processes. They are designed to prevent organic shock loads from industrial users like food processing plants from overloading the activated sludge process. The BOD loading for a standard rate trickling filter is about 15-20 pounds per day/1000 cubic feet of media. Hydraulic loading ranges are from 1-4 mgd/acre (25-100 gpd/ft<sup>2</sup>). BOD loadings for high rate filters can be as high as 40-60 lbs per day/1000 cu.ft. Hydraulic loading for high rate filters runs from 10-40 mgd/acre.

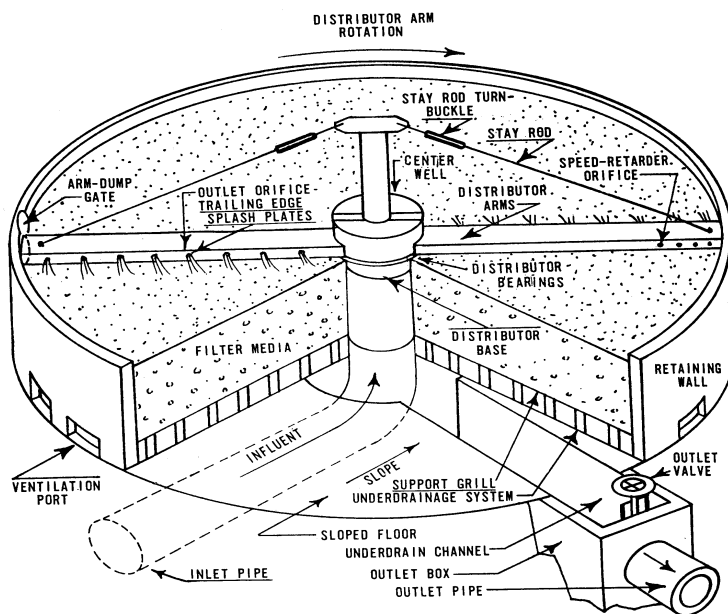

## **ZOOGLEAL FILM**

The microorganisms that grow on the trickling filter media create a layer of slime that is known as the zooglear film. The bacteria and protozoa that make up this film are responsible for consuming the raw organic material, both suspended and dissolved, that remains in the primary effluent. As this layer of organisms gets thicker it falls off of the media. This process is known as sloughing. The sloughed material is collected in the secondary clarifier as sludge and removed from the process. Snails and psychoda flies (filter flies) can also be found in the filter box. They are a nuisance but can be controlled. If the slime layer gets too thick, it can fill the gaps between the rocks. This results in ponding of water on top of the media. Air must pass through the media to keep everything aerobic in the filter. Ponding prevents air from circulating through the media below it. When this occurs, septic conditions and odors begin to develop in the filter.

With enough air and the constant dose and rest cycle created by the rotating distributor arm, these aerobic organisms will stay healthy and hungry. The growth of the zooglear film represents the conversion of dissolved organic compounds (sugars, starches, and fats) into solids (bugs) that can be removed from the process by physical separation in the secondary clarifiers.

## **TRICKLING FILTER OPERATIONS**

One of the big problems with trickling filters is that the BOD removal efficiency is only about 80-85%. This usually results in effluent BOD concentrations that do not meet current permit limits. Trickling filters have sometimes been placed in series, or stages, so the flow passes through two filters. Running through the second filter increases the overall removal efficiency, but not enough to meet today's standards. Removal efficiencies are calculated by comparing the BOD strength in the primary clarifier effluent and the secondary clarifier effluent.

Recirculating trickling filter effluent back is another means of achieving higher removal efficiencies. The filter effluent or the secondary clarifier effluent is returned to the filter for a second pass. All high rate filters recirculate and many standard filters have been re-fitted for recirculation. Adjusting the recirculation rate is the only real process control for most trickling filters. Recirculation flows need to be increased at night to maintain flows high enough to keep the distributor turning at the right speed. Increasing recirculation can also be used to help control filter flies and ponding.

As flows drop off at night, the DO and pH in the filter will drop. This can also lead to septic conditions in the filter. Increasing the recirculation will aerate the flow, increase the ventilation draft, and reduce the detention time in the filter. This will usually bring the effluent DO back up to the normal 1.5-2.0 mg/l range. Aeration will also strip carbon dioxide from the water. This will cause the pH to rise. If the filter experiences an upset, increasing the recirculation will help reduce the recovery time. Normal recirculation rates will need to be increased during colder weather to maintain removal efficiencies. The lower temperatures will reduce biological activity and single-pass efficiencies.

## ROTATING BIOLOGICAL CONTACTORS (RBC)

Rotating biological contactors operate under the same fixed media principle as a trickling filter. The difference is the fixed media disks rotate in the water. The media is attached to a rotating horizontal shaft and is about 40% submerged in main tank. As the media rotates it picks up some wastewater that runs down the media as it comes out of the water. This creates contact time with the organisms on the media and allows for air to circulate throughout the core of the media to maintain aerobic conditions. RBCs should be preceded by primary treatment. Grit and sludge accumulation beneath the disks can cause septic conditions to develop.

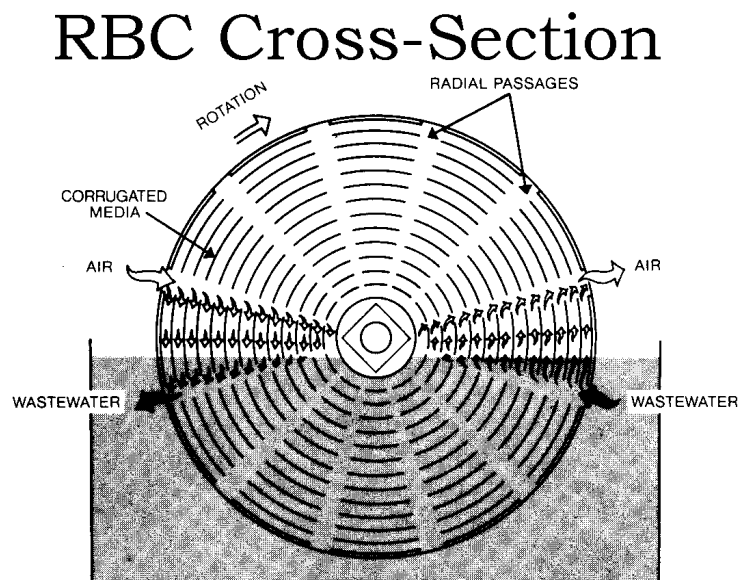

End-view sketch illustrates exchange  
of air and wastewater

Just like a trickling filter, the growth on the media sloughs off as it gets heavier. It must be carried out of the tank to a clarifier. This requires that a minimum velocity of 1 fps be maintained to keep the sloughings in suspension. This is sometimes accomplished by the addition of an aeration system. Aerated RBCs do not carry as much biomass on the media due to the scouring effects of the air diffuser. In some cases RBCs have been converted to a hybrid activated sludge processes by aerating and returning secondary sludge to the process (RAS) to build up mixed liquor suspended solids. Since most RBC systems are plug flow processes, the first stages will have more growth on the media than the last stages.

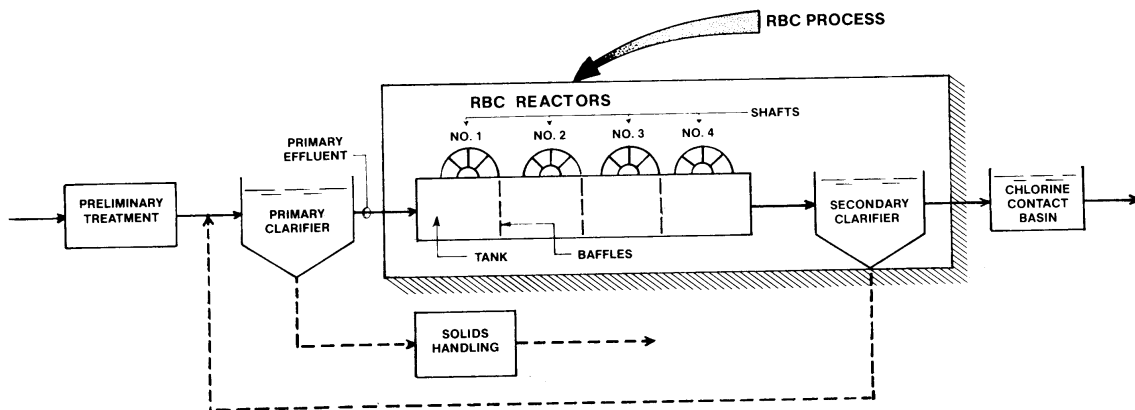

The rotating media is usually mechanically driven with a sprocket and chain drive. Some units are air-driven. The aeration diffusers are located under the disks and the rising air turns the media. The rotational speed is adjusted by adjusting the airflow. The key operational issue in a RBC is that the media must never stop turning. The rotational speed provides the main source of aeration in an un-aerated RBC. It must be maintained at 1.0-1.5 rpm. In the event of a power failure, the media should be rotated 1/4 turn every 4 hours. When the media is allowed to stop for too long the growth on the submerged portion of the media will continue. The biomass on the exposed portion of the media will dry up and fall off. This creates an unbalanced condition that will damage the drive unit.

RBCs are usually designed in multi-staged processes. When RBCs are designed for nitrification, the media growth and DO levels are different in the front and back stages. The front stages will remove most of the BOD. The DO can be as low as 1 mg/l in the first stage and the growth will be a gray shaggy mass. With the BOD gone, the DO levels will rise to 4-5 mg/l in the final stages. The higher DO levels are needed for nitrification to occur. The biomass will be thinner and dark brown in color. When BOD overload occurs, the growth will turn black. A toxic upset will result in a milky-white appearance.

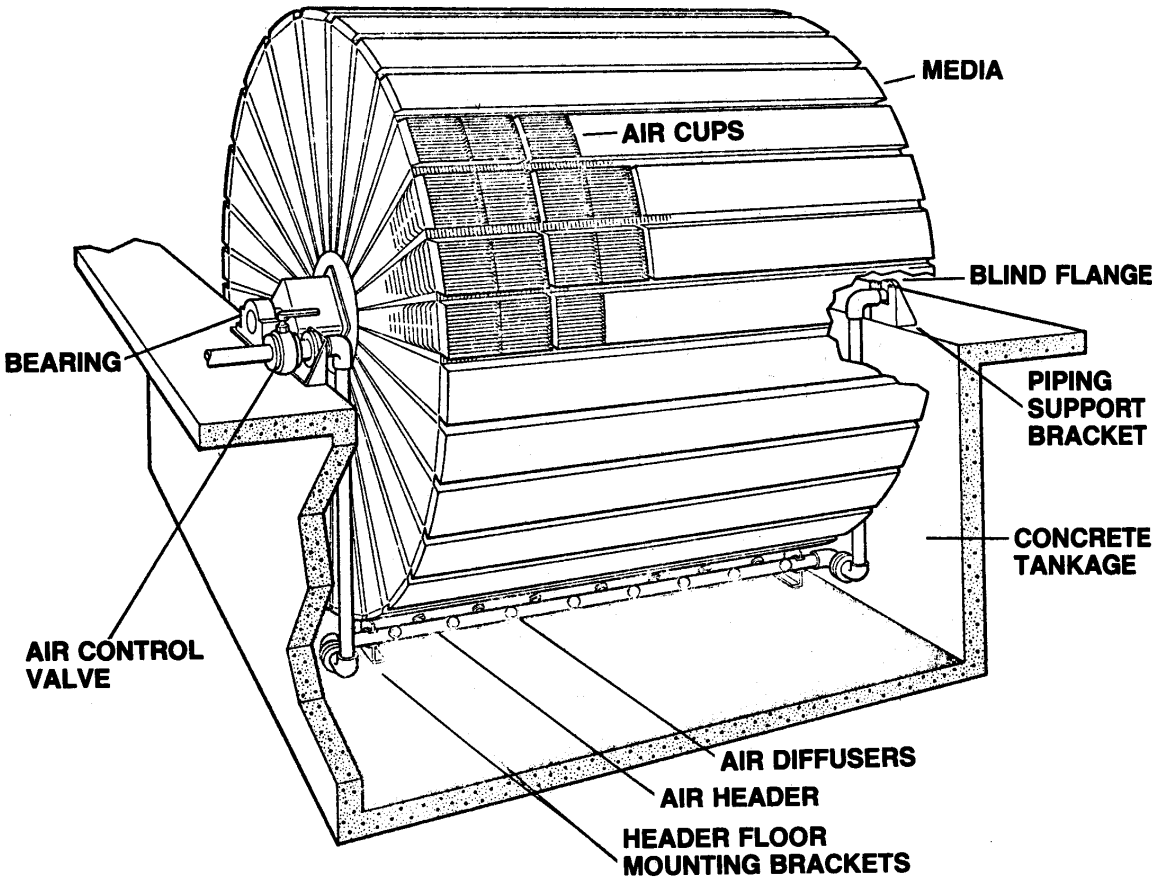

## Air Driven RBC

### **BASIC STUDY QUESTIONS**

1. What are the components of a:
    - A. Trickling filter
    - B. RBC
  2. What can be done to keep a distributor arm turning during low flows?
  3. What is the material that sloughs off the media called?
  4. What should precede a RBC in the treatment process?
4. How do high rate filters differ from standard rate filters?
    - A. They have higher organic loading
    - B. They have higher hydraulic loading
    - C. They are taller
    - D. All of the above

### **ADVANCED STUDY QUESTIONS**

1. How do you control filter flies and ponding in trickling filters?
2. What is the most important operational consideration with an RBC?
3. List four things that can be accomplished by increasing recirculation rates in trickling filters?

### **BASIC SAMPLE TEST QUESTIONS**

1. What should the effluent DO be in a trickling filter?
  - A. 0 mg/l
  - B. 0.4-0.8 mg/l
  - C. 1.5-2.0 mg/l
  - D. 6.0-8.0 mg/l
2. Which of the following is a problem in trickling filters?
  - A. Snails
  - B. Ponding
  - C. Psychoda flies
  - D. All of the above
3. To maintain air flow through a trickling filter, make sure that:
  - A. The blowers are running
  - B. The underdrain is no more than 50% full
  - C. There is ponding on the surface

### **ADVANCED SAMPLE TEST QUESTIONS**

2. What is the BOD loading for a high rate trickling filter?
  - A. 10-15 lbs/day/1000 ft<sup>3</sup>
  - B. 20-30 lbs/day/1000 ft<sup>3</sup>
  - C. 40-60 lbs/day/1000 ft<sup>3</sup>
  - D. 80-100 lbs/day/1000 ft<sup>3</sup>
3. Healthy growth on the first stage of an RBC will be:
  - A. Gray
  - B. Brown
  - C. Black
  - D. White
4. The DO in the last stage of a nitrification process in an RBC should be at least:
  - A. 1 mg/l
  - B. 2 mg/l
  - C. 4 mg/l

## SECONDARY TREATMENT – ACTIVATED SLUDGE

Activated sludge is another biological process used to remove organics from wastewater. Like the trickling filter, activated sludge processes are used to grow a biomass of aerobic organisms that will breakdown the waste and convert it suspended solids. This is accomplished in large aerated tanks instead of the trickling filter's fixed media. These tanks are called aeration basins. Activated sludge processes return settled sludge to the aeration basins in order to maintain the right amount of bugs to handle the incoming food. The “free range” aspect of suspending the organisms in the flow results in higher removal efficiencies in activated sludge processes (95-98%) compared to trickling filters (80-85%).

### ACTIVATED SLUDGE TERMINOLOGY

**MLSS/MLVSS** - These organisms that are responsible for removing the BOD make up a large portion of the solids that are contained in the process. They are the "active" part of activated sludge. The solids under aeration are referred to as the Mixed Liquor Suspended Solids or MLSS. The portion of the MLSS that is actually eating the incoming food is referred to as the Mixed Liquor Volatile Suspended Solids or MLVSS. The inventory of the biomass, or the herd of critters, is calculated as pounds of microorganisms based on the volume of the tanks and the concentration of the MLVSS.

**RAS/WAS** - As the mixed liquor moves to the secondary clarifiers, the activated sludge settles to the bottom of the tank and is removed. This sludge is not as thick as primary sludge. The solids concentrations will normally be between 0.5-0.8 percent or about 5,000-8,000 mg/L. One of two things will happen to the settled sludge. Most of it will be returned to the aeration basins to keep enough activated solids in the tanks to handle the incoming BOD. This is known as the Return Activated Sludge or RAS. A small portion of the sludge will be removed from the system as the MLSS inventory grows. It is referred to as Waste Activated Sludge or WAS.

**Detention time** - Detention time, or the length of time the MLSS are under aeration, differs with each type of activated sludge process. RAS flows can be used to manipulate the detention time in the aeration tanks. Increasing the RAS flow at night will help maintain the proper detention times as influent flows drop.

**F:M Ratio** - One of the process parameters used to control activated sludge solids inventory is known as the Food-to-Microorganism ratio or F:M ratio. It is a baseline established to determine how much food a single pound of organisms will eat every day. A pound of bugs will eat between 0.15-0.6 pounds of food per day depending on the process.

**MCRT or Sludge Age** - Another control parameter is the length of time the bugs stay in the process. If a system wastes 5% of the solids in the system every day, then MLSS would only remain in the system an average of about 20 days ( $100\% / 5\% \text{ per day} = 20 \text{ days}$ ). This is known as the Mean Cell Residence Time or MCRT. Some operators also refer to this number as Sludge Age.

SVI - The sludge volume index or SVI is a measurement of how well the activated sludge settles in the clarifier. Sludge settleability in a large part depends on the condition of the organisms. Good settling sludge will have an SVI between 80 and 120. As the sludge becomes lighter and the settled volume increases the SVI will also increase. The units for SVI are milliliters per gram of solids. If the SVI is 100, there is one gram of solids in every 100 milliliters of settle sludge. SVI can be used to calculate the number of gallons that must be moved to remove one pound of solids.

## ACTIVATED SLUDGE PROCESSES

There are basically three types of activated sludge processes. They all accomplish the biochemical reduction of organics using aeration basins with the capability to return and waste sludge from the process. The detention times, MLSS, and F:M loadings are different for each process. The one control parameter that they all share is a dissolved oxygen range of 2.0-4.0 mg/L. The minimum DO requirement is 1-2 mg/L. The fact that aerobic conditions exist in the aeration basin means that the mixed liquor should have a light earthy odor that is not objectionable. Dissolved oxygen levels are maintained by aeration equipment using blowers and diffusers or mechanical aerators.

## CONVENTIONAL ACTIVATED SLUDGE PROCESSES

Conventional activated sludge has an aeration basin detention time of 4-6 hours. Most of the BOD from the primary effluent will be dissolved or very small suspended particles. The MLSS concentrations usually run from 2000-3500 mg/L. F:M ratios should be between 0.2-0.5. MCRT or sludge age varies from 5-15 days.

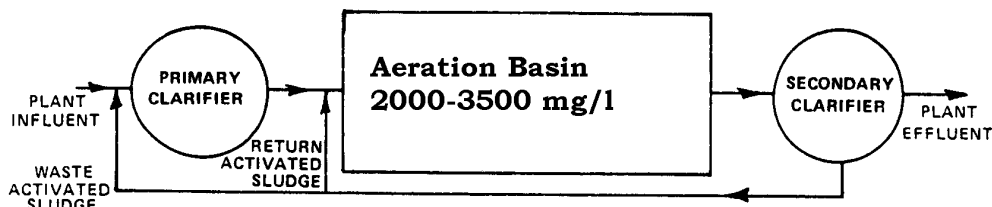

**Conventional Activated Sludge**

## CONTACT STABILIZATION PROCESSES

Contact stabilization uses two separate aeration processes. The primary effluent enters the contact chamber where the bugs begin to break down the dissolved BOD and increase the overall settleability of the organics that are not yet oxidized. The raw organics and MLSS settle out in the clarifier just like conventional activated sludge. But instead of returning the RAS to the contact basin, it is pumped to another aeration basin called a stabilization basin. Here the RAS is aerated until the remaining heavy solids have been eaten or stabilized by the bugs. The effluent from the stabilization basin is returned to the contact basin to maintain the MLSS concentration and the process begins again.

The main advantage of the contact stabilization process is that most of the solids and BOD reduction happens off-line from the main flow in the stabilization basin. This prevents massive solids losses during hydraulic shocks on the system and reduces recovery time since the bulk of the biomass is kept in the stabilization basin.

The detention time in the contact basin is from 0.5-2.0 hours. The detention time in the stabilization basin is from 4-8 hours, about the same as conventional processes. The MLSS concentrations will run from 1200-2000 mg/L in the contact chamber and will be 4,000-6,000 mg/L, the same as the RAS, in the stabilization chamber. Contact stabilization has the highest F:M ratios. The F:M ratio can run as high as 0.60-0.75.

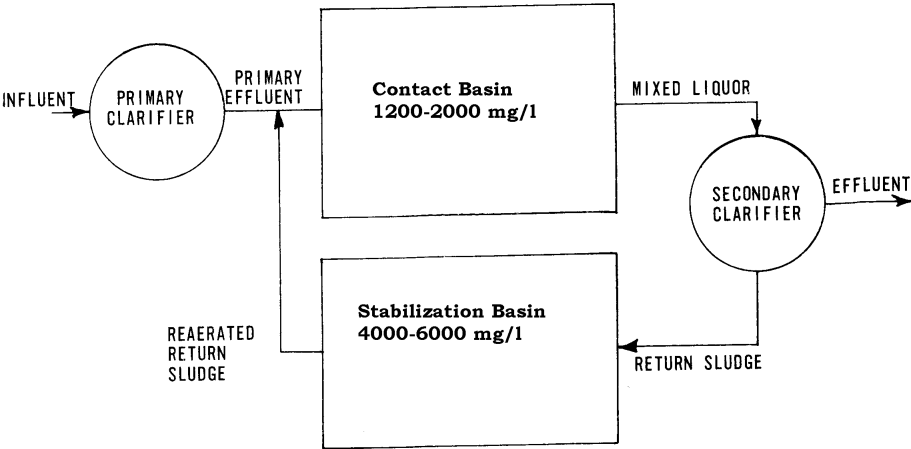

**Contact Stabilization**

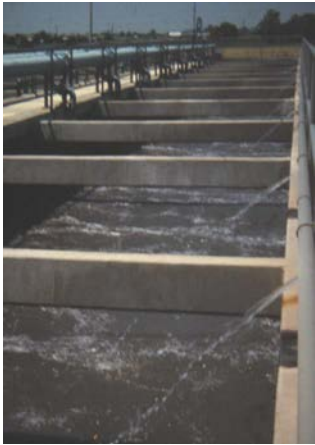

**Contact Basin solids on the left  
Stabilization Basin solids on the right.**

## EXTENDED AERATION PROCESSES

Extended aeration systems are designed to completely stabilize all of the organic material in the aeration basins. The detention times range from 16-24 hours and MLSS ranges run from 3000-5000 mg/L. They have the lowest F:M ratios of any of the activated sludge processes, usually in the 0.15-0.25 range. Extended aeration plants are cheaper to build because they have no primary clarifiers or anaerobic digester systems. RAS is returned to the head of the aeration basin and waste sludge is sent to an aerobic digester.

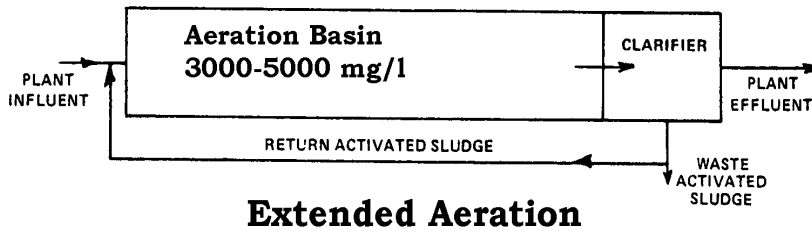

## OXIDATION DITCHES

An oxidation ditch is a form of extended aeration activated sludge. The aeration basin is a large oval shaped tank that resembles a racetrack. Wastewater enters the ditch and is circulated around the track by means of a large horizontal brush/rotor. The rotor assembly is partly submerged in the ditch. As it rotates it pushes the mixed liquor and supplies the needed aeration to maintain a DO level of about 2 mg/L in the basin. The BOD loading for oxidation ditches can vary between 10-50 lbs/1000 cu ft/day. The oxidation ditch effluent passes to the secondary clarifier and RAS is returned to the ditch.

The velocity and DO levels can be adjusted by changing the rotor speed and operating depth. The effluent weir is a slide gate that can be raised and lowered to change the water level in the ditch. This also changes how deep the rotor is submerged in the mixed liquor. Running deeper increases the DO levels but dramatically increase power consumption. The proper velocity for an oxidation ditch should be above 1 foot/sec. If the velocity falls below 1 fps, there is a possibility that sludge will settle in the turns. This will result in septic conditions and odors.

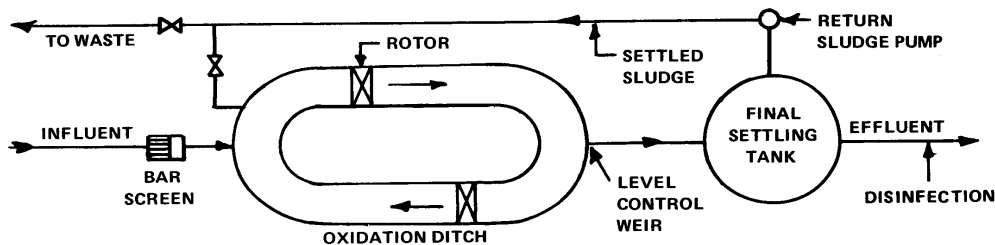

Some ditches are designed with a concrete wedge at the exit of each bend. The wedge forces the water from the inside to the outside of the track. This helps mix the flow and creates turbulence where settling is most likely to occur. Oxidation ditches, like other extended air systems, do not have primary treatment. Pretreatment maybe limited to barscreens. This means that grit will not be removed until it settles out in the oxidation ditch. The grit buildup in the ditch can result in odors and loss of detention time. It should be removed anytime the unit is drained for service.



**Activated sludge oxidation ditch treatment plant**



**Aerator rotor assembly provides DO and mixing**

### SEQUENCED BATCH REACTOR (SBR)

A sequenced batch reactor is a process that is used in package plants and small municipal systems. It is not a continuous flow process. The reactor basin is filled and then aerated for a certain period of time, usually 1-3 hours. After the aeration cycle is complete, the reactor is allowed to settle and effluent is decanted from the top of the unit.

When the decanting cycle is complete, the reactor is again filled with raw sewage and the process is repeated. These processes are popular because everything happens in one tank. Most SBRs do not have clarifiers or RAS systems. A large equalization basin is required in this process, since the influent flow must be contained while the reactor is in the aerating cycle.

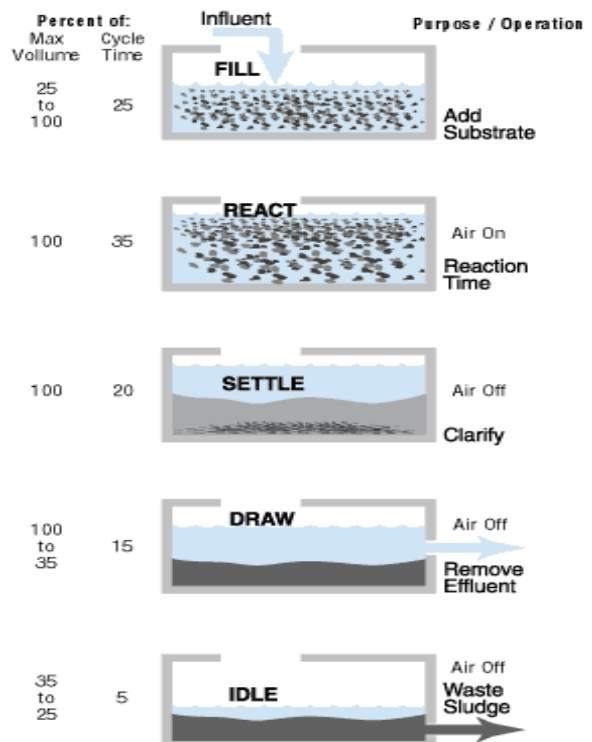

## BIOLOGICAL GROWTH RATE

The respiration rate or metabolism level of the biomass will dictate how much food each pound of bugs can eat every day. The goal is to achieve what is known as endogenous respiration. At this rate of metabolism the bugs are working at their maximum efficiency. The oxygen uptake rate (OUR), or system oxygen uptake rate (SOUR), is used to determine if endogenous respiration is being achieved. The oxygen uptake rate is calculated by measuring the amount of DO that is depleted from a sample of mixed liquor in 15 minutes. The uptake rate is obtained by multiplying the 15-minute depletion by four to get a value in mg/L per hour. Most cases, endogenous levels of respiration are achieved when the oxygen uptake rate is between 15-30 mg/L per hour.

If they were left in the aeration basins all of the time, these organisms would literally suffer burnout from operating at such a high level of activity. Their ability to consume food would drop dramatically over time. When they pass to the clarifier they get a chance to rest and digest their food. Just about the time that they start getting hungry again, they should be returned to the aeration basins to eat. This cycle keeps the biomass at its optimum activity level. The growth rate of the biomass is dependent upon the available oxygen, F:M ratio and temperature.

## INFLUENT FLOW PATTERNS

Most treatment plants put the entire influent flow in one end of the process and take it out the other end. This type of flow pattern is called plug flow. The flow runs in series from one stage to the next. Plug flow patterns put a high organic load in the front stage of the process and the BOD drops of in each consecutive stage. Since the amount of air needed is directly related to BOD loading, this means that a great deal more oxygen is needed in the first stages than in the latter ones. Problems maintaining DO levels can occur. The system is also subject to upset if an organic shock load occurs

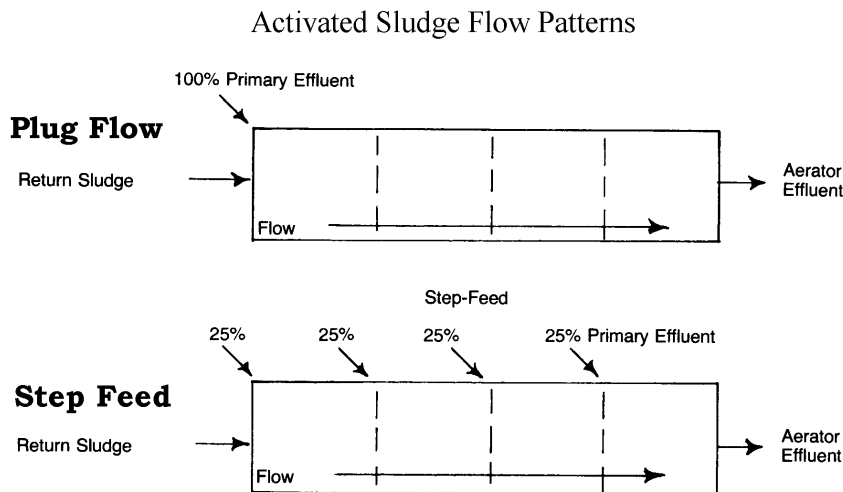

Another flow pattern that is used in some plants is called a step feed process. In a step feed process the influent flow is split and a portion is sent to each stage of the process. This is similar to running lagoon cells in parallel. It makes better use of aeration and makes shock organic loads, which could cause upsets in a plug flow process, easier to handle. When nitrification requirements went into permits in the early 1980s, higher DO levels were needed at the end of the process. Many step feed systems reverted to plug flow to get the DO levels of 4-6 mg/L in the final stages.

The third type of flow pattern is called complete mix. This flow pattern usually occurs in extended aeration plants. The influent enters the center of a single stage aeration basin and leaves at the edge. The location of the aerators and mixers is designed to create uniform MLSS loading

## **PROCESS CONTROL**

There are three parameters that are adjusted to maintain efficient operation of an activated sludge process. They are dissolved oxygen levels, RAS flows, and WAS flows. When diffuser type aerators are used, the DO levels are established by controlling the amount of airflow to each basin. If DO levels are too high the flow can be throttled using valves on the air header pipes. In most cases the air system is branched to each tank. Throttling the flow to one tank will increase the flow to others. When the diffusers get clogged the airflow will drop dramatically. The diffusers can be bumped with a sudden burst of air to help clear them. In severe cases, they may need to be cleaned using hydrochloric acid fumes. Balancing the airflow between the basins, to maintain the proper DO levels, is an important part of maintaining an efficient operation.

Return activated sludge flows are important because the microorganisms must be returned to the aeration tanks before they run out of dissolved oxygen. They spend about two hours in the clarifier during average flows. During that time they will use up the 2-4 mg/L of DO that they had when they entered the clarifier. If they are not returned to the aeration basin in time, their metabolism rate will drop off. The longer they go without air the longer it will take for them to build up their metabolism rate to the endogenous levels needed to meet the F:M ratio. Return sludge pumping capacity should be 50-70% of average daily flow. As the flows drop at night, the detention time in the clarifiers gets longer. To compensate, the RAS flows are increased to reduce the detention time in both the aeration basin and the clarifiers. Increasing the RAS flow will also reduce the depth of the sludge blanket in the clarifier. This will help reduce bulking during peak flow periods.

Wasting sludge is how the F:M ratio is maintained. As the biomass eats the organics it creates more bugs. The excess must be removed to keep the MLSS levels constant. WAS flow rates are usually 1-2% of the influent flow. When the MLSS level increases the sludge age increases. This older sludge will not settle as well and can result in poor settling and solids leaving the clarifier. When this occurs, the wasting rate should be increased to remove more solids from the system. When light tan colored straggler floc is going over the weirs, it is usually an indication that the sludge age has decreased. The wasting rate should be reduced to increase the sludge age or MCRT.

Care should be taken when changing wasting rates. A sudden increase in the WAS flow can lead to an upset of the process. Changes in wasting rates should be made gradually. Never change WAS rates by more than 10% each day to minimize the impact on the process. The idea is to get to the new MLSS levels in two weeks instead of two days. It is important to remember that it takes a long time to see results from process changes. A startup may take up to 60 days and it may take 1-2 MCRT cycles to see the results from adjusting the F:M ratio.

## **ACTIVATED SLUDGE MICROORGANISMS**

Almost all of the BOD reduction in activated sludge is a result of the activity of the aerobic bacteria that are present. But an entire food chain develops as a result of the bioactivity. Protozoa that are large enough to be seen with a microscope occupy the upper regions of the food chain. Their numbers and activity can provide information regarding the health of the bacterial colony. There are five categories of these activated sludge protozoa. The predominance of one or more of these groups over the others can give an indication of the age and condition of the sludge. They are listed below in order of appearance as the sludge matures.



An amoeba is a single celled organism that is the first to develop in the sludge. They are found in sludge regardless of sludge age. Flagellates are the next organisms to develop. They have a large single cell body with a whip like appendage called a flagellum. They are predominant, with the amoeboids, when the sludge is very young. Young sludge has a poor settleability and a high SVI. Translucent straggler floc in the effluent is another indicator of young sludge age. As the sludge age increases the number of flagellates will drop.

Free swimming ciliates are small oval shaped bugs with tiny hairs or cilia. These cilia move in a wave-like motion to propel them in the water and bring food to them. Their numbers increase as the sludge reaches maturity and achieves its best settleability and then drop off as the sludge age continues to increase. Stalked ciliates look like a cluster of flowers attached to a sludge particle. Their tulip shaped bodies have cilia that are also used to bring food to them. The ciliates eat bacteria and very small organic particles. They are also responsible for moving microscopic particles into larger floc particles to help improve settling and effluent clarity. The free swimmers and stalks are the predominant groups in good settling sludge and they both decline as the sludge ages.

Rotifers are the most complex organisms of the group. They have nine cells and are larger than the other organisms. They have a long telescoping body and can attach themselves to a floc particle or move through the water much like a caterpillar. They are first seen in sludge as straggler floc disappears with increasing sludge age. Their numbers continue to increase as the sludge ages. They are predominant in old sludge. When they are predominant, very small pin floc particles appear in the effluent because there are not enough ciliates to move water and clump them up.

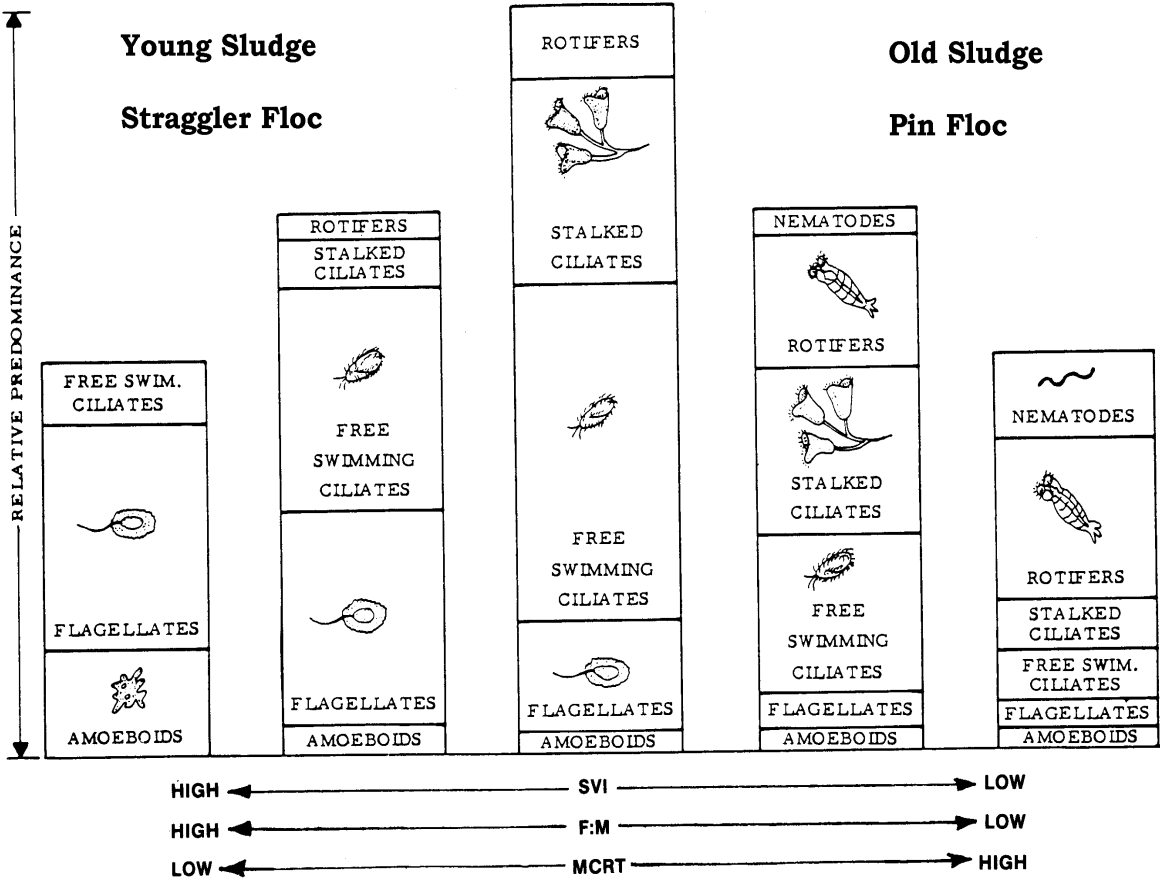

### THE "BUG" CHART

#### SLUDGE PROBLEMS

Sludge blanket problems manifest themselves in several different ways. Straggler floc is common in young sludge. It can be eliminated by reducing wasting and increasing the sludge ages or MCRT. Pin floc problems occur as the sludge becomes too old. It can be remedied by increasing wasting rates to reduce the sludge age.

Filamentous bacteria are long stringy bacteria that are always present in activated sludge. They are beneficial in small numbers. They help stick sludge particles together. In large numbers they create a condition known as particle bridging and reduce the settleability of the sludge. When this occurs, bulking sludge problems that look like an explosion of floc particles can develop. Bulking sludge is dark brown in color and can also be accompanied by dark, oily foam accumulation in the aeration basins. *Nocardia* is a type of filament that is known to cause bulking and foaming problems in activated sludge. They have a lower metabolism and usually become a problem when there is an upset and BOD is not removed by the good guys. The addition of 1.0-1.5 mg/L of chlorine to the RAS flow is often used in activated sludge systems to control filaments. Sludge will also bulk when solids stay in the clarifier too long and the DO drops. The ciliates will stop moving water and particles won't settle as well. This usually occurs during the peak flow period and the increase in upward velocities in the clarifiers.

Hydraulic shock loading can cause a washout or blowout of the sludge blanket. When the upward velocity in the clarifier suddenly exceeds the settling velocity of the sludge, the solids are blown out of the tank and over the weirs. Flow equalization basins are the only way to avoid hydraulic shock to the system when flows spike.

Rising sludge occurs when the DO is depleted and denitrification occurs. Chunks of sludge will float to the surface as nitrogen gas is released and trapped in the sludge blanket. Besides losing solids from the system, these conditions mean the bugs are also very sick and may not perform well when they are returned to aeration.



**Hydraulic shock loading can cause a blowout of the sludge blanket**

## **AERATION TANK FOAM**

The bioactivity in the aeration basins will always result in some foam buildup in the basin. If there is no foam in the aeration basin the biomass is likely dead. The color of the foam is an indicator of sludge age and condition. Crisp white foam is indicative of young sludge. Rich medium tan foam is associated with good settling sludge. Dark brown oily foam can be found in older sludge. It is common in aerobic digesters, but not a good sign in an aeration basin. It is the result of filamentous bacteria problems.

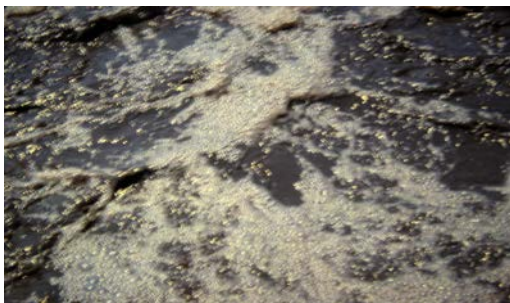

**Tan colored foam is a sign of good settling sludge**

### **BASIC STUDY QUESTIONS**

1. What are the differences in MLSS concentrations and detention times the three activated sludge processes?
2. What should the DO levels be in activated sludge aeration basins?
3. What type of activated sludge process does not have primary clarifiers?
4. What is meant by the term plug flow?
5. What does the "F" in F:M ratio stand for?
4. Which of the following statements is not true about filamentous bacteria?
  - A. They are always present in MLSS
  - B. Too many can lead to bulking
  - C. They like a low pH
  - D. They indicate a young sludge age
5. Which of the following is a filamentous bacterium?
  - A. E. Coli
  - B. Nocardia
  - C. Nitrosomonas
  - D. Giardi

### **BASIC SAMPLE TEST QUESTIONS**

1. What is the aeration basin detention time in conventional activated sludge processes?
  - A. 1-2 hours
  - B. 4-6 hours
  - C. 10-12 hours
  - D. 16-24 hours
2. What should the velocity be in an oxidation ditch?
  - A. 0.01 fps
  - B. 0.2 fps
  - C. 1.0 fps
  - D. 3.0 fps
3. What type of odor is associated with activated sludge processes?
  - A. A light earthy odor
  - B. A fruity odor
  - C. A rotten egg odor
  - D. An acrid odor

### **ADVANCED STUDY QUESTIONS**

1. What is the main advantage of a contact stabilization process?
2. What does the term sludge age or MCRT mean?
3. What are the differences in the three types of influent flow patterns for activated sludge processes?
4. Why should RAS flows be increased at night?
5. What are the F:M ratio ranges for each of the three types of treatment processes?

## ADVANCED SAMPLE TEST QUESTIONS

1. What is the SVI range for good settling sludge?
  - A. 20-50
  - B. 60-70
  - C. 80-120
  - D. 130-210
  
2. Straggler floc would be found in:
  - A. Young sludge
  - B. Old sludge
  - C. Good sludge
  - D. Primary sludge
  
3. Wasting rates should never be changed by more than \_\_\_\_ at a time.
  - A. 1-%
  - B. 10%
  - C. 30%
  - D. 60%
  
4. What microorganisms are predominant in very old sludge?
  - A. Flagellates
  - B. Free swimming ciliates
  - C. Rotifers
  - D. Stalked ciliates
  
5. White crisp foam in the aeration basin indicates:
  - A. A young sludge
  - B. A mature sludge
  - C. An old sludge
  - D. A good beer

## TERTIARY TREATMENT

A tertiary treatment process is any process that occurs after secondary treatment. It can be polishing processes that improve suspended solids removal or nutrient removal processes. Nutrient removal includes processes like nitrification/denitrification, ammonia stripping, phosphorous precipitation, and land application or overland flow.

### EFFLUENT POLISHING

Effluent polishing is a physical treatment process to remove effluent suspended solids. Effluent polishing is normally accomplished by filtration of secondary effluent in an effort to remove suspended solids caused by bulking solids or pin floc problems. These filters are similar to those used to treat drinking water.

### RAPID SAND FILTERS

Conventional rapid sand and mixed media filters have many design similarities. The basic components of a filter are described below. The main differences will be in the type of media that is used and the valving configurations.

**Filter boxes** may be constructed as rectangles, squares, round, or as the outer segment of a ring. A filter box is approximately ten feet deep. Its surface dimensions will vary depending on the volume of water to be filtered.

The **underdrain** serves three basic functions. Although it supports the filter media and collects the filtered water, its most important function is to evenly distribute the backwash water throughout the filter. Leopold tile and Wheeler blocks are two popular types of underdrain systems

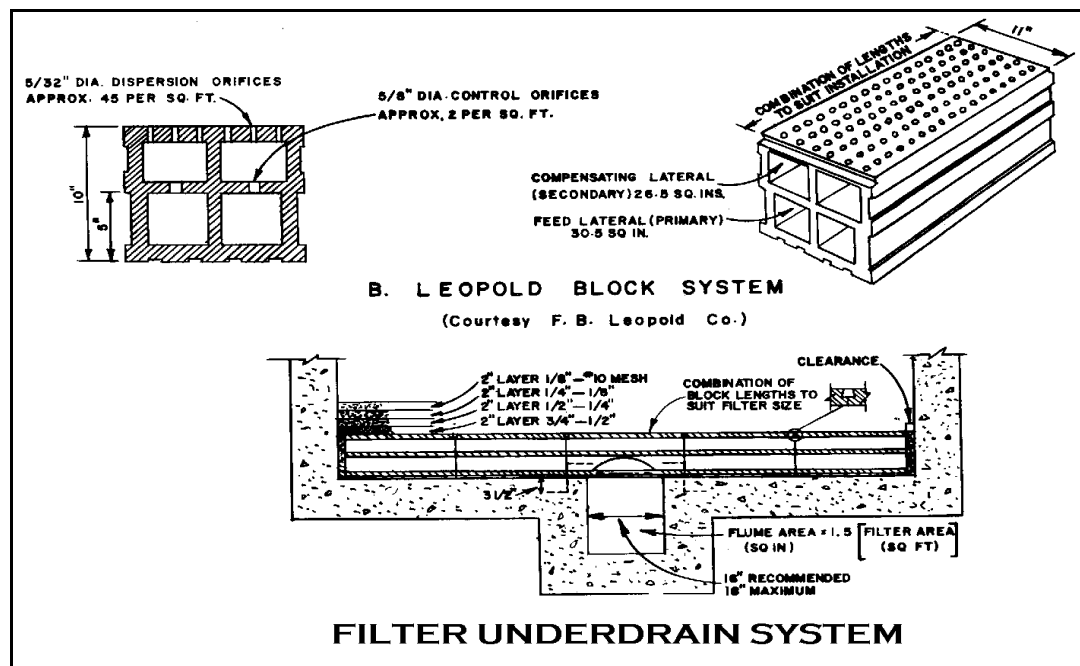

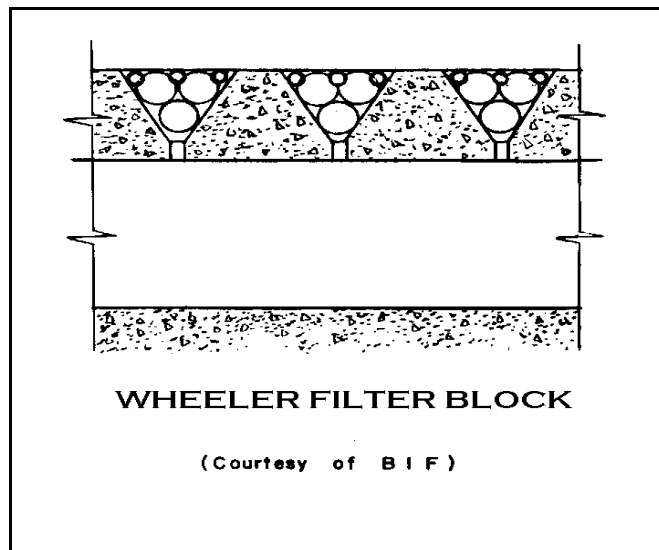

Filter media consists of sand, gravel, and small rocks of varying sizes. Six to eight inches of small rock is placed on top of the filter underdrain. A layer of pea gravel is placed on top of the rocks, usually three to six inches in depth, followed by layers of gravel of increasingly smaller size. This material will support the sand and keep it away from the underdrain. The actual filter media is a layer of silica size sand about 24 inches in depth. This sand should be sized so that the grains are between 0.3 to 0.6 millimeters in diameter. The uniformity coefficient for the sand media should be at least 0.9. This means that 90% of the grains will fall within the 0.3-0.6 mm range. Modern multi-media filters have three different layers of filtering media. The top layer is anthracite coal. The middle layer is silica sand. The bottom layer is garnet sand.

The rate of flow controller maintains a constant flow of water throughout the filter run. As the filter media becomes clogged the rate of flow controller opens a valve on the effluent line that compensates for the head loss through the filter. When the head loss reaches 8 feet, the rate of flow controller is fully open. The proper flow rate for a rapid sand filter is 2 gpm/sqft. Dual media filters run at 3-5 gpm/sqft. Multi-media filters operate at 5-8 gpm/sqft.

Loss of head gauge indicates when the filter is in need of backwashing. The loss of head is determined by the difference between the level of water in the filter and the level of a column of water that represents the pressure in the effluent line. This is referred to as the feet of head loss through the sand bed. When the head loss reaches 8 feet the filter should be backwashed.

Five valves are needed to properly operate a filter. The influent and effluent valves are open during normal operation and closed during backwash. The "backwash valve" provides a means for cleaning the filter and the waste valve allows the backwash water to leave the filter. A fifth valve, the surface wash valve, is also used when surface washers are installed. Surface washers of some type will usually be found on all new filter installations.

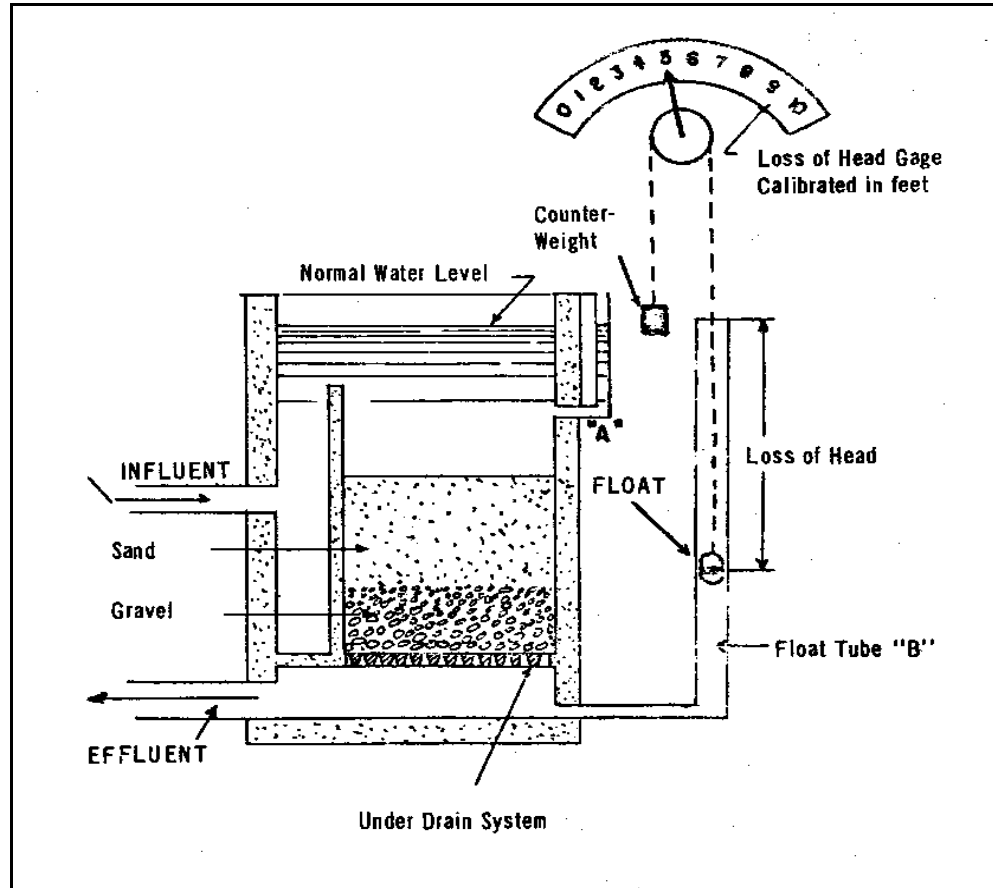

### Loss of Head Gauge

Backwash troughs collect the backwash water and transport it out of the filter. These troughs should be no farther than six feet apart and the top of the trough should be between 24-28 inches above the filter media. This is known as the freeboard of the filter. In filters that use anthracite coal in the media, the freeboard should be 32-36 inches to prevent loss of media during backwash.

Surface washers are used during the backwash cycle to agitate and break up the top layer of media where most of the dirt is trapped. This step helps reduce the amount of backwash water needed and the time it takes to properly clean the filter.

A backwash pump or tower is used to supply the backwash water to the filter. It must be capable of supplying at least 15 gpm/sq. ft. of filter area. Enough backwash water must be available to run the backwash for 10-15 minutes on average. The backwash water will be treated effluent in a wastewater plant. The backwash water is usually sent to an equalization basin and then back to the headworks of the plant. If the backwash rate is too low or the backwash run is ended too soon, the media will develop mud balls. If it is too high, media may be blown out of the filter.

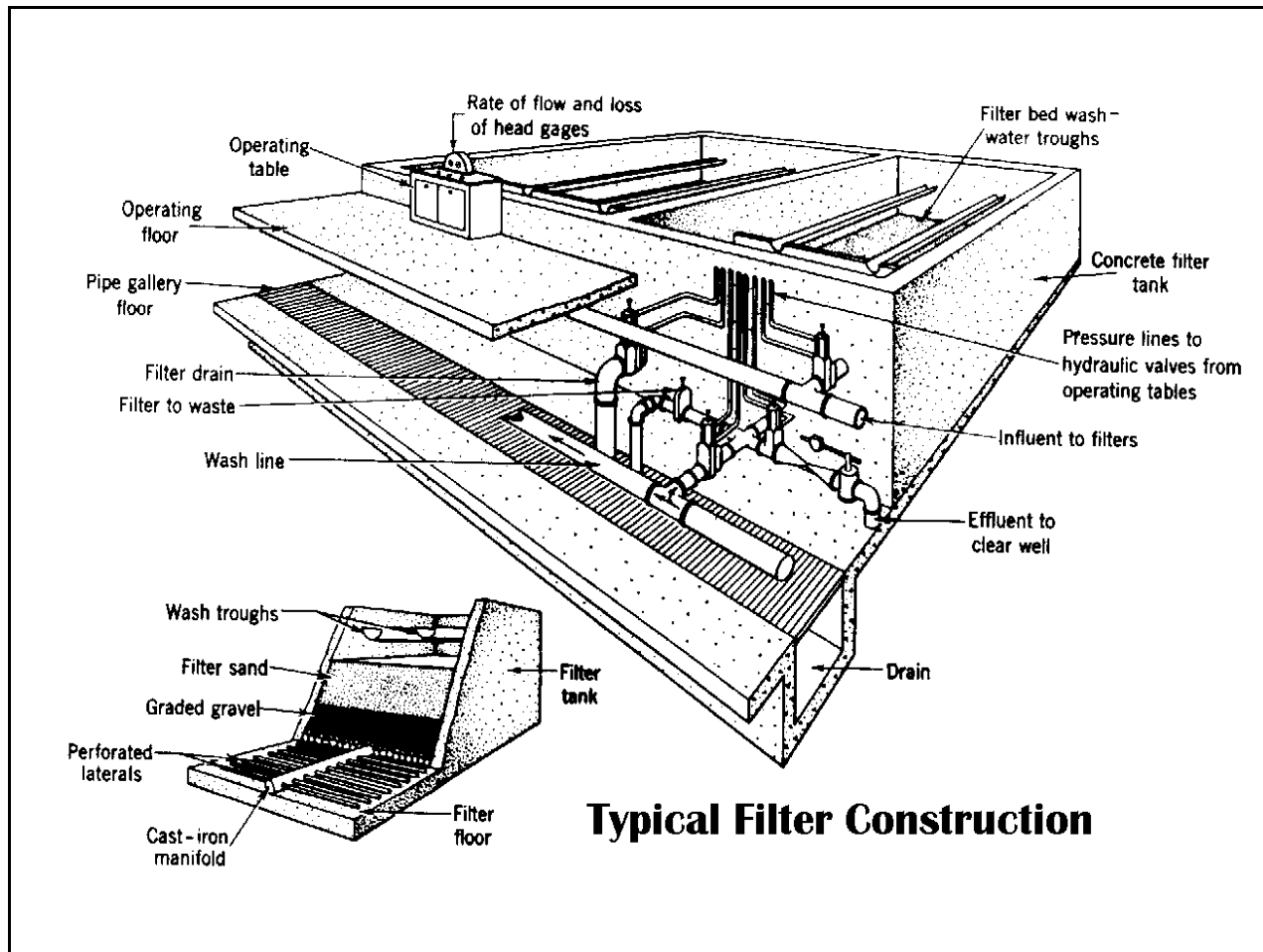

## EFFLUENT POLISHING PONDS

Effluent polishing ponds are shallow aerobic lagoons that receive treated secondary effluent. They are sometimes mechanically aerated. The non-aerated ponds will stay aerobic because there shouldn't be much BOD left to create an oxygen demand. Usually wind action and surface oxygen transfer will provide adequate aeration since the ponds are only 2-3 feet deep. They provide a final chance to lower the effluent BOD. They may also provide the detention time and U-V radiation from sunlight to naturally dechlorinate the effluent after disinfection. The problem with all lagoons is the increase in TSS created by the algae in the cell.

## NUTRIENT REMOVAL

The first goal of wastewater treatment is to remove suspended solids and BOD. Suspended solids created sediment in the receiving waters and organics will continue to decompose, using up oxygen in the river or lake. There are also problems with other chemicals in the waste stream that affect aquatic wildlife and directly impact the water quality of the receiving waters. Nitrogen and phosphorous compounds in the wastewater effluent can be toxic to fish and can act as natural fertilizers that increase the growth rate of aquatic plants like algae and mosses. As ammonia is converted to nitrates by oxidation, dissolved oxygen is depleted from the receiving waters. Nitrates and phosphorous are fertilizers that can be responsible for algae blooms that can choke out other aquatic life in the lake or river.

The first treatment processes that dealt with the nitrogen issue were nitrification processes. The intent was to convert the ammonia that was present in the secondary processes into nitrates prior to discharge. This would create a more stable form of nitrogen and minimize the oxygen depletion that would occur in the river. But the nitrates still acted as an aquatic fertilizer that created algae problems. Denitrification processes were developed to convert nitrates to elemental nitrogen gas that can be stripped from the effluent by aeration.

## NITRIFICATION

Nitrification of wastewater will occur after most of the BOD has been removed. If enough dissolved oxygen is available, nitrifying bacteria like *Nitrosomonas* will begin oxidizing ammonia ( $\text{NH}_3$ ) to nitrites ( $\text{NO}_2$ ) first. Then *Nitrobacter* bacteria convert the nitrites ( $\text{NO}_2$ ) to nitrates ( $\text{NO}_3$ ).

This process requires a tremendous amount of oxygen. It takes 4-6 pounds of oxygen to convert one pound of ammonia to nitrates. Dissolved oxygen levels need to be at least 4 mg/L to accomplish nitrification. Alkalinity is also removed during this process. About 7 pounds of alkalinity will be consumed to each pound of nitrogen that is oxidized.

Nitrification usually occurs in the latter stages of multi-staged activated sludge systems and extended aeration systems. The long detention times give the biomass time to stabilize the BOD and then oxidize the ammonia to nitrates. Multi-staged RBC processes can also nitrify if they are aerated to maintain the higher DO levels.

## DENITRIFICATION

The most common process used to remove the nitrogen completely is known as denitrification. It follows the nitrification process. It utilizes denitrifying bacteria to remove the oxygen from the nitrate compounds. Nitrates are converted into nitrogen gas ( $\text{N}_2$ ), which effectively removes the nitrogen from the waste flow.

All bacteria need oxygen for respiration. The aerobic bacteria get their oxygen for dissolved oxygen in the water. The anaerobic and facultative bacteria still need oxygen too. When no DO is present, they get oxygen from stripping chemically bound oxygen from organic chemicals and inorganic chemicals like sulfates and nitrates, releasing  $\text{CO}_2$ ,  $\text{CH}_4$ ,  $\text{NH}_3$ , and  $\text{H}_2\text{S}$  in the process. Denitrifying bacteria are facultative and can use the oxygen in nitrates for respiration. In order for them to use this chemically bound oxygen, the DO must be less than 0.1 mg/L. This is known as an anoxic condition. Anoxia is the chemical equivalent of anaerobic biological conditions.

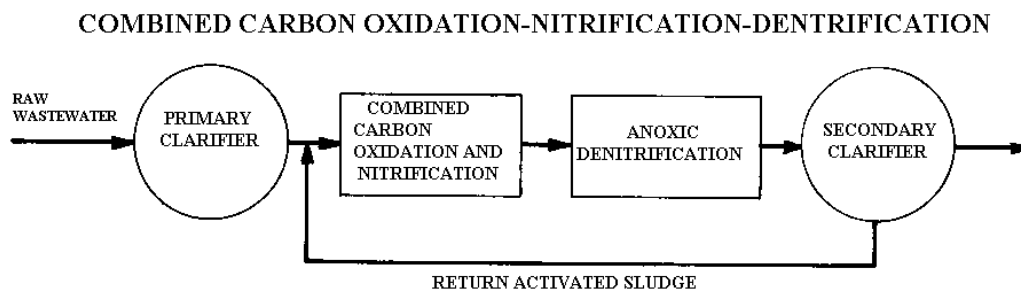

The denitrification process follows nitrification. The dissolved oxygen level leaving the nitrification process is usually 4-6 mg/L. This DO must be removed quickly so that denitrification can begin. Some denitrification processes rely on the addition of a carbon source, like methanol, that facultative bacteria can use to burn up the remaining dissolved oxygen. Once this accomplished, the denitrifying organisms will begin to use the oxygen in the nitrates for respiration. The nitrogen gas that is released in the process is removed by aeration prior to final clarification. This is a gas stripping process that causes the water to give up nitrogen gas as it absorbs oxygen. The effluent DO levels should be brought back up to 2.0 mg/L.

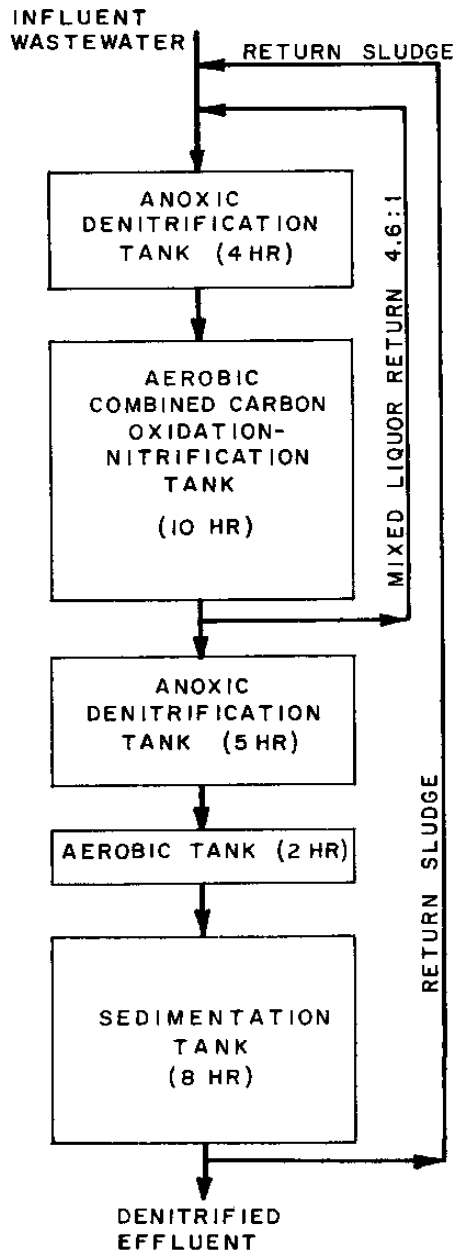

**Bardenpho Denitrification Process**

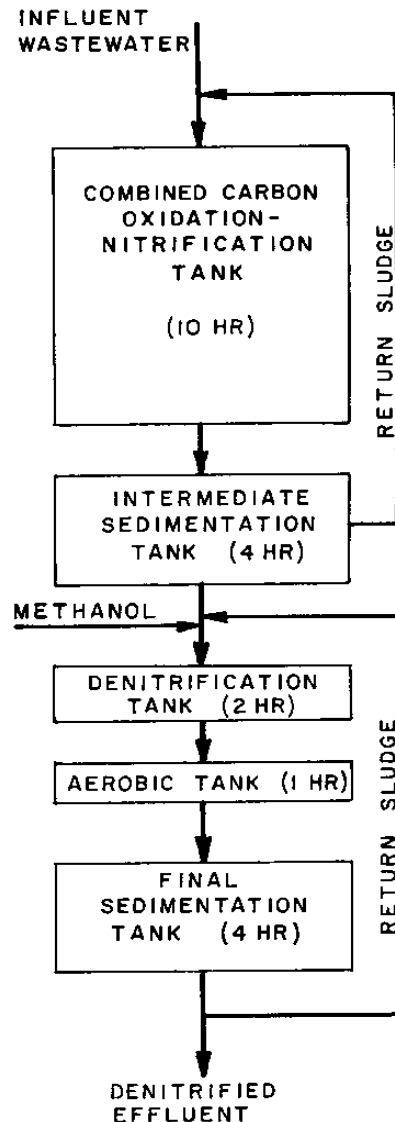

**Methanol Denitrification Process**



**Denitrification Basin  
Anoxic Stage**



**Denitrification Basin  
Final Aeration Stage**

The two most common denitrification processes are the Bardenpho and the methanol processes. The Bardenpho process uses an anoxic influent basin followed by a standard BOD/nitrification process, but no clarification. Mixed liquor is returned to the front of the process instead of RAS. Another extended anoxic basin is used to reduce the dissolved oxygen and create denitrification. The effluent passes to an aeration basin where the gas stripping process occurs and then to clarifiers. The RAS is returned to the head of the process. The main disadvantage of the Bardenpho process is the extended detention time in the two anoxic processes.

A standard activated sludge nitrification process with intermediate clarification precedes the methanol denitrification process. The methanol addition allows the bacteria to burn up the remaining dissolved oxygen very quickly. The denitrification stage is accomplished in about two hours followed by a one-hour aeration cycle for gas stripping. The RAS is returned to the front of the denitrification basin instead of the head of the plant.

Denitrification can occur in most activated sludge processes. The problem is that it usually occurs in the clarifiers. This can cause rising sludge problems. The situation is similar to what happens in the primary clarifiers when sludge sits in the tank too long and goes septic. The release gases from the decomposition causes the sludge to rise. The main difference is that the gas that floats the secondary sludge is nitrogen gas.

Denitrification may also occur in some oxidation ditch processes. An oxidation ditch only has one or two points (the rotor brushes) where DO is added to the process. As the mixed liquor moves around the basin, the DO is used up and anoxic conditions may be created on the backside of the oval ditch. This anoxic zone can promote denitrification. Anoxic cycles can be programmed into SBR sequencing to achieve denitrification.

## **OXIDATION REDUCTION POTENTIAL (ORP)**

One of the problems with denitrification is determining if it is actually occurring. Achieving anoxic conditions does not guarantee that the organisms are denitrifying. Some systems are now using the oxidation reduction potential or ORP to determine how long it will take to remove the nitrates. Since the removal of oxygen from nitrates is a reduction reaction, the denitrification cycle must be long enough to achieve an ORP of -50 to -100 mv.

## **OTHER NITROGEN REMOVAL PROCESSES**

Other options for removing nitrogen from wastewater include ammonia stripping towers, water hyacinth lagoons, land application/overland flow, chemical oxidation, and ion exchange. Gas stripping to remove ammonia is a physical treatment process that takes advantage of two of the laws of dissolved gases in water. First, there is a limit to the amount of dissolved gas that water can hold. The limiting factors are changes in temperature or pressure. Second, water prefers dissolved oxygen to other dissolved gases like carbon dioxide (CO<sub>2</sub>), hydrogen sulfide (H<sub>2</sub>S), or ammonia (NH<sub>3</sub>). If oxygen is available, water will absorb it and release the other gases to atmosphere. The stripping tower will provide the aeration that allows this to happen. There is one major drawback to the ammonia stripping process. The pH must be in the 10.5-11.0 range. This exceeds regulatory limits. So the pH must be raised to 10.5 and then another pH adjustment is needed to get back down to 9.0 before it can be discharged. This physical/chemical treatment process is not popular because of the chemical cost.

Water hyacinth is a form of aquatic vegetation that has an amazing ability to remove pollutants from water. Ponds containing hyacinth plants have been used to remove any number of heavy metal pollutants in some industrial applications. The hyacinth's growth rate causes plant mass to double every 2-3 weeks. In the process, it soaks up a huge amount of nitrogen. The problem with hyacinth operations is that excess vegetation must be harvested every month. Disposal options include composting or landfilling. If it is used for heavy metal removal landfilling may not an option. Many states will not allow the importation of hyacinth plants due to concerns that they will spread to receiving streams and lakes.

Land application of the plant effluent for irrigation is another alternative that has become more popular as water reuse has increased over the years. One of the factors that limit the rate of application would be nitrate nitrogen migrating into groundwater supplies. Monitoring wells located near the disposal site are a permit requirement. Groundwater samples must be collected to check for nitrate contamination. Effluent applied to public recreational areas must be properly disinfected.

Overland flow systems are designed for retrieval and discharge of the effluent unlike an irrigation project that has no discharge to a receiving stream. A clay and loam soil is graded to a 1-1.5% downhill slope. The clay soil needed for overland flow projects limits the amount of groundwater intrusion. It is seeded with a grass that has a high nitrogen uptake like rye or alfalfa. Treated effluent is allowed to run down the slope where it is collected in a channel at the bottom. As the grasses fill in the area, they impede the flow of water and give the plants and microorganisms in the soil a chance to absorb the nitrogen. The plants will soak up some of the flow and there will be some evaporation during the process. The discharge flow will also be reduced by 30-50%. The nitrogen is removed from the process by harvesting the crop.

Chemical oxidation of ammonia with chlorine is possible. It takes a 10:1 ratio of chlorine to ammonia. In the early 1980s a number of large systems began adding chlorine to create chloramines in an effort to meet the new ammonia limits in their permit. This resulted in effluent Total Residual Chlorine (TRC) concentrations in the 20-30 mg/L range. At normal disinfection levels, chlorine in the effluent did not present a threat to aquatic life. But these higher levels were toxic to most aquatic life in the receiving waters. The EPA responded by adding dechlorination requirements to all NPDES permits after 1986.

## PHOSPHOROUS REMOVAL

Phosphorus removal is usually achieved with a physical/chemical process. Phosphorous can be precipitated as a floc particle using the same process that surface water systems use to soften drinking water. Alum or lime can be used as the coagulant. The treatment equipment will include tertiary flocculation and sedimentation processes followed by effluent filtration. Phosphate-accumulating organisms (PAO) are also capable of removing phosphorous in SBRs. They break polyphosphate bonds for energy when anoxic conditions exist and an ORP of -150 to -200 mv is achieved during the fill cycle. They will then absorb the phosphates during the aeration cycle.

## ADVANCED STUDY QUESTIONS

- Why is the filter backwash rate important?
- Which gas is liberated during denitrification?
- Why must anoxic conditions be achieved during the denitrification process?
- What is the problem associated with ammonia stripping?
- Which two chemicals can be used to precipitate phosphorous?
- What does the filtration term freeboard refer to?
- Which bacteria are responsible for oxidizing nitrites to nitrates?
  - Nitrobacter
  - Nocardia
  - E. Coli
  - They all nitrify
- If chlorine is used to oxidize ammonia the ratio will need to be:
  - 2:1
  - 5:1
  - 7:1
  - 10:1

## ADVANCED SAMPLE TEST QUESTIONS

- Ammonia discharged to the receiving stream is a problem because:
  - Ammonia is toxic to fish
  - Natural oxidation will remove DO from the stream
  - It will increase algae growth
  - All of the above
- The dissolved oxygen requirement for nitrification is about:
  - 2-3 pounds per pound of nitrogen
  - 4-6 pounds per pound of nitrogen
  - 7-9 pounds per pound of nitrogen
  - 10 pounds per pound of nitrogen



## DISINFECTION

The process of killing the pathogenic bacteria found in the wastewater effluent is known as disinfection. Disinfection is the final step in wastewater treatment and is necessary to provide a measure of bacteriological safety for those who use the receiving waters for recreational purposes or come in contact with treated effluent that is land applied for irrigation. The only systems that do not have to disinfect are those with subsurface disposal fields. Chlorination is commonly used for disinfection.

While chlorine is used primarily for disinfection in wastewater treatment, it also has other uses in the treatment process. Chlorine can be used to kill filter fly larvae in trickling filters. It is also used to inhibit filamentous bacteria growth in activated sludge processes. Chlorine is sometimes used for odor control in collection systems. The growing concern regarding chlorine and chlorine by-products in wastewater effluents has resulted in the requirement to de-chlorinate to remove chlorine before it is discharged to the environment.

Chlorine is the most widely used disinfectant because it is readily available, easily applied, and cheaper than other oxidizing agents such as ozone ( $O_3$ ) or potassium permanganate. Although ozone is more expensive, it does not require de-chlorination since the by-product is dissolved oxygen. Ultraviolet disinfection processes are also replacing chlorination for the same reasons. Chlorine is applied in one of three forms; chlorine gas, chlorine powder (HTH), or an aqueous solution of chlorine bleach.

### CHLORINE GAS

Chlorine gas ( $Cl_2$ ) is cooled and compressed into a liquid for storage. It can be purchased in cylinders containing 150 or 2000 pounds of the liquefied gas. Chlorine gas is cheaper per pound than either of the other forms.

### CHLORINE POWDER

Chlorine in its dry form is calcium hypochlorite [ $Ca(OCl)_2$ ]. It is also most commonly known by the trade name HTH (High Test Hypochlorite). Only about 65 – 70% of the HTH is available as chlorine. The rest is calcium, which is not a disinfectant. Dry chlorine is 2-3 times more expensive per pound of chlorine than chlorine gas.

### CHLORINE BLEACH

Chlorine bleach is a liquid solution of sodium hypochlorite ( $NaOCl$ ). Bleach is usually 6-15% available chlorine. Bleach is the most expensive form of chlorine and is normally used for disinfecting small wells and water lines. A bleach solution will lose 2-4% of its available chlorine each month at room temperature. It should be used within 60-90 days.

## CHLORINE TREATMENT TERMS

Several terms are used to identify the various reactions that occur when chlorine is used as a disinfectant. The basic unit of measurement for chlorination is milligrams per liter or mg/L. These are very small units reflecting concentrations that are equivalent to one pound chemical for every million pounds of water. To get some idea of how small a concentration this really is, it should be pointed out that 1% is equal to 10,000 mg/L.

### CHLORINE DOSAGE

The chlorine dosage is the amount of chlorine that is added to the water. The dosage can be determined by dividing the number of pounds of chlorine used and the number of millions of pounds of water treated.

### CHLORINE DEMAND

Chlorine is a very reactive oxidizing agent. It will react with a number of chemicals that may be found in water. This list includes; iron, manganese, hydrogen sulfide, organic compounds and ammonia. When chlorine reacts with these substances, it loses its ability to kill pathogens. This is referred to as the chlorine demand. For chlorine to be effective as a disinfectant, the dosage must always exceed the demand that is present in the water. The chlorine demand may vary from day to day in a wastewater system.

### CHLORINE RESIDUAL

The chlorine that remains in the water after it has finished reacting with those substances that represent the demand is known as the chlorine residual. The concentration of the residual is determined by subtracting the demand from the dosage.

**EXAMPLE:** A 4.0 mg/l dosage is added to water that has a demand of 2.5 mg/l.  
What is the residual?

$$\begin{array}{rcl} \text{Dosage} & - & \text{Demand} & = & \text{Residual} \\ 4.0 \text{ mg/l} & - & 2.5 \text{ mg/l} & = & 1.5 \text{ mg/l Residual} \end{array}$$

There are two types of residuals that result from the chlorination of water. They are free chlorine residual and combined chlorine residual.

## FREE CHLORINE RESIDUAL

After the demand has been satisfied, any chlorine that is left will react with water to form hydrochloric acid and hypochlorous acid.



The hypochlorous acid, HOCl, is the disinfecting agent and the free chlorine residual is the concentration of the hypochlorite ion ( $\text{OCl}^-$ ). Calcium hypochlorite will react with water to form hypochlorous acid and calcium hydroxide. Sodium hypochlorite will react with water to form hypochlorous acid and sodium hydroxide.

## COMBINED CHLORINE RESIDUAL

Chlorine reacts with water to form hypochlorous acid. If ammonia is present, the hypochlorous acid will react with it to form compounds known as chloramines.

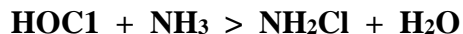

There are three different chemicals formed as chlorine reacts with ammonia. They contain from one ( $\text{NH}_2\text{Cl}$ ) to three ( $\text{NCl}_3$ ) atoms of chlorine. They are referred to as monochloramine, dichloramine and trichloramine respectively. The water chemistry and concentration of chlorine will dictate which of the chloramines are formed. Chloramines are weak disinfectants. They require longer contact times and higher concentrations to achieve disinfection than free chlorine residual. However, they do not breakdown as quickly as free chlorine and remain in the system longer.

## DISINFECTION REQUIREMENTS

Two factors must be taken into consideration when disinfecting wastewater. First, enough chlorine must be added to reach a predetermined concentration in the water. Then the bacteria must come in contact with the solution for a certain period of time. This is referred to as achieving the proper residual and contact time. A minimum of 0.2-0.4 milligrams per liter (mg/L) of free chlorine residual and a contact time of 20 minutes will be necessary. If chlorine is used to kill filter fly larvae, or break up ponding, the dosage should be 0.5-1.0 mg/L. For filament reduction in return activated sludge (RAS) the dosage should be 1.0-1.5 mg/L.

## EFFECTS OF TEMPERATURE AND pH

Changes in temperature and pH of the water can reduce the effectiveness of chlorine. Colder temperatures slow down reaction times requiring higher concentrations and longer contact times to achieve proper disinfection. At a higher pH, a higher chlorine dosage will be required to achieve proper disinfection.

## BREAKPOINT CHLORINATION

When chlorine is added to water that contains no ammonia, the residual that is obtained will be free available chlorine. If ammonia is present the demand has been satisfied and some of the free chlorine will react with the ammonia to form chloramines or combined chlorine residual. As more chlorine is added, it will convert the chloramines that have been formed from monochloramine to trichloramine. The trichloramines are the weakest disinfectants and, as a result, the combined residual reading will begin to drop. A point will be reached where the residual will begin to rise again when a free residual is established. There may be some combined residual left in the water at this point. From this point, any additional increase in the chlorine dosage will result in the formation of free chlorine. This is known as the breakpoint. All water systems that chlorinate their water are achieving breakpoint chlorination. They will add enough chlorine to the water to achieve a free chlorine residual of at least 0.2-0.4 mg/L.

The Breakpoint Curve shown below illustrates the formation and destruction of chloramines before free residuals are achieved. Every system's breakpoint will vary depending on the chemical makeup and chlorine demand of the raw water.

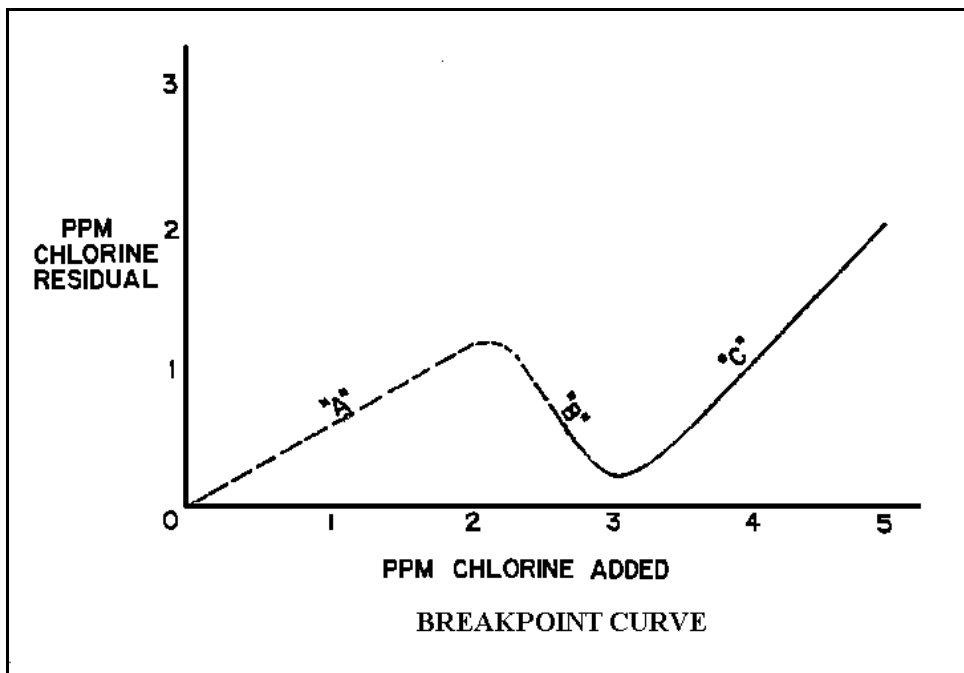

As chlorine is added to the water, it reacts with the ammonia that is present and a combined residual reading is formed (A). In this case, as the dosage increases to about 2 ppm (mg/L) the combined residual drops because the chloramines are being destroyed (B). When the dosage reaches 3ppm (mg/L), the breakpoint occurs and first free chlorine residual is found. Once the breakpoint has been reached, the free residual will increase at the same rate as the dosage (C).

## TESTING FOR CHLORINE RESIDUALS

There are three methods that are used to test water for chlorine residual. Two of them are field tests. The Ortho-Tolidine-Arsenite (OTA) test was the industry standard until the mid - 1970's. The problem with the OTA test was that iron and nitrites in the water would interfere with the test. In addition, OTA was found to be a carcinogen. It is no longer used for chlorine residual testing today. Instead, the Diethyl-p-Phenylene-Diimine (DPD) test is used for field work. It is similar to the OTA test but there is no interference from other chemicals. A third test for chlorine residual is known as the amperometric titration method. It is normally run in a laboratory.

The DPD test is a colormetric analysis. The reagent is added to a vile of sample water. Another vile of sample water serves as a blank. If chlorine is present the sample will turn pink or red. The blank is placed in front of the color wheel and the sample is compared to the color wheel and blank. There are two chemical packets for the DPD test. One is used for free chlorine and the other is used for total chlorine residual. Subtracting the free residual from the total residual will give you the combined residual. Although the color wheel kit can be used for field tests, a residual meter must be used for reporting purposes.

### General Chlorine Safety

Chlorine is a greenish-yellow gas. It is 2.5 times heavier than air. Chlorine gas is very corrosive. It turns into hydrochloric acid when it comes in contact with moisture in the water, in the gas chlorine lines, or in your eyes or lungs. It does not support combustion. It can be harmful if inhaled in small quantities and fatal in larger doses that exceed 40-50 mg/L. Chlorine leaks can be located using ammonia vapors. The following table lists the effects of chlorine gas in various concentrations in the atmosphere.

SYMPTOM	CONCENTRATION
Noticeable odor	0.2 ppm
Irritation after several hours - PEL	1.0 ppm
Irritation of throat after a few minutes	15 ppm
Immediate coughing	30 ppm
Lethal after 30 minute exposure	50 ppm
Lethal in a few minutes	1000 ppm

## **CHLORINATOR ROOM**

The chlorinator room should have a window in the door so that the operator in the room can be seen from the outside. The light and vent switches should also be located outside the room. The room should have ventilation located at floor level since chlorine gas is heavier than air and will settle in the lowest spot in the room.

The room should be kept between 60°F and 120°F. Below 60°F, chlorine gas forms chlorine hydrate, also known as “green ice,” when it comes in contact with water. This green ice can clog the injector and gas piping, creating a serious maintenance problem.

A 150 pound cylinder is about 85% full of liquefied chlorine at room temperature. As the temperature rises, the liquid expands and takes up more space in the cylinder. At 157° F the liquid will expand to occupy 100% of the cylinder. If the liquid expands any further the cylinder will rupture. The resulting release of liquefied chlorine gas is a worst case scenario.

Never enter a chlorine facility unless the ventilation system is operating. The National Fire Code now requires that new gas chlorine facilities be equipped with a scrubber system that will remove chlorine gas that may be present in the ventilation exhaust. These systems must have a backup power supply to keep the scrubber running in the event of a power failure. Check with local Fire authorities before new chlorine facilities are built to make sure they will be in compliance.

## **CHLORINE STORAGE**

The room where chlorine cylinders or HTH drums are stored must be kept dry and well ventilated. Chlorine should always be stored in a room separate from other chemicals. Chlorine cylinders that are empty should be separated from those that are full. When not in use, all cylinders should be chained to the wall. Safety hoods must be in place anytime the cylinder is not connected to the system.

## **CHLORINE CYLINDERS**

NEVER remove the valve hood from a chlorine cylinder unless it is chained to the scales and ready to be put on the system. All cylinders should be chained to the wall or the scales unless they are being moved. Emergency repair kits are available that can be used to seal leaks in the broken valves or leaking cylinders. Every system that operates a gas chlorine system should have an emergency kit or be able to get access to one on very short notice.

To prevent the cylinder from rupturing when it gets too hot, every gas cylinder will have a fusible plug that is designed to melt at 157-161° F. There is one in the valve assembly of every 150 lb. Cylinder and six in every 1-ton cylinder. Three fusible plugs are installed in each end. As one of these fusible plugs melts, it will allow the release of chlorine gas from the cylinder. This still represents a serious problem, but the release will be more gradual than it would if the tank ruptured and released liquefied gas.

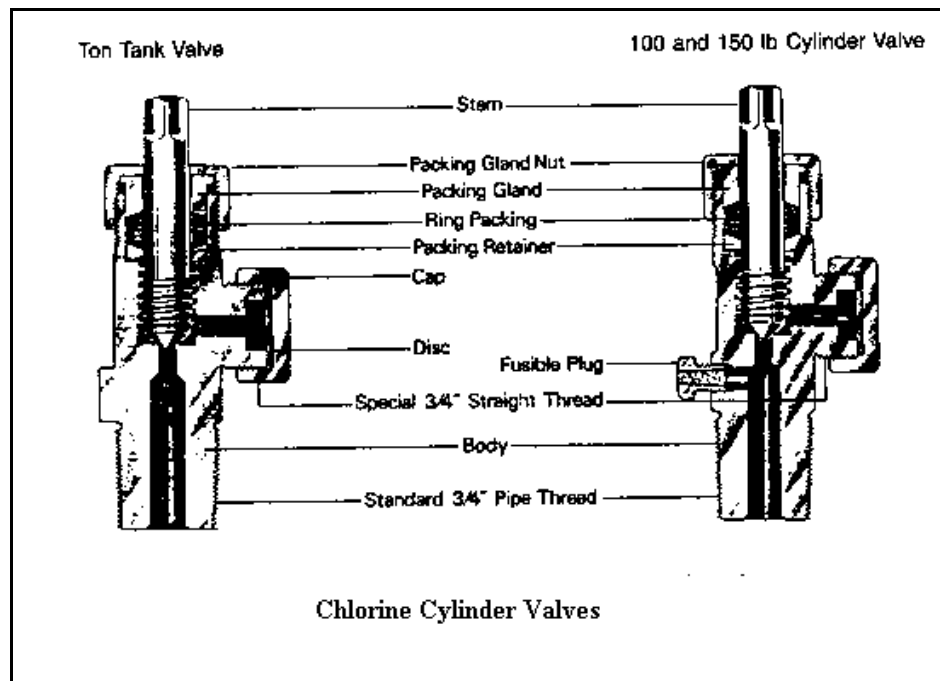

## HTH AND BLEACH HANDLING SAFETY

Powdered chlorine should be stored in a cool dry place separate from other chemicals. HTH and bleach must never be allowed to come in contact with petroleum products or organic hydrocarbons. If this happens, these chemicals will explode. Contaminating the product with acids will result in chemical decomposition and the release of chlorine gas. Care must also be taken to avoid contact with the eyes or bare skin.

Bleach should also be handled with care. In higher concentrations it becomes unstable. Bleach decomposes (releases chlorine vapors) at temperature above 104-176°F. Materials that should not come in contact with bleach include strong acids, heavy metals, oxidizable materials, reducing agent, hydrocarbons, and other organic materials.

## RESPIRATORY PROTECTION

Anyone involved in handling chlorine should have access to respiratory protection equipment. Chlorine gas forms hydrochloric acid when it gets in the eyes or lungs. The damage caused by exposure to chlorine gas is cumulative and irreparable. Several incidents involving minor exposure can contribute to serious health problems later in life.

There are two basic types of respiratory protection. One is the gas mask that uses a filtering device to remove chlorine. These can be either a full-face mask or a mouth and nose type respirator. The other type of respirator is the self-contained breathing apparatus, or SCBA. The SCBA unit is full-face mask with an air tank to provide the operator with supplied air to breathe in hazardous atmospheres. Both of these devices may be rendered ineffective if the wearer has facial hair that interferes with the face-to-mask seal.

## **GAS MASKS**

The gas mask is designed to allow the operator time to escape the chlorine room when a leak occurs. **THESE DEVICES ARE INTENDED FOR ESCAPE PURPOSES ONLY! A GAS CANISTER MASK MUST NEVER BE USED TO ENTER ANY AREA WHERE CHLORINE GAS IS PRESENT!** If an operator is wearing a canister mask he must still leave the area immediately upon detection of a chlorine leak. The gas canisters should be changed every six to twelve months, or anytime it has been exposed to chlorine gas.

## **SELF-CONTAINED BREATHING APPARATUS (SCBA)**

The SCBA unit must be used when working in a known chlorine gas atmosphere. It has a compressed air tank that allows the wearer to breathe uncontaminated air while attempting to correct a chlorine leak situation. The SCBA tank will hold enough air for approximately thirty minutes, depending on working conditions. When the air pressure drops to a point where there is about five minutes of air remaining in the tank, or around 500 psi, an alarm will ring to signal the operator that it is time to exit the area and change tanks. Employees should have refresher training in SCBA use monthly.

## **CHLORINATION EQUIPMENT**

There are two ways to feed chlorine into the water system. Gas chlorination uses liquefied chlorine gas. Hypochlorination systems use a positive displacement pump to feed a solution of dissolved HTH or bleach into the system. Many smaller systems use a hypochlorination system because the equipment cost is lower. The solution of dissolved HTH or bleach is much easier to handle and presents less of a risk compared to a gas system. Gas chlorination is used where the system requires larger dosages of chlorine than can be delivered by hypochlorination. Though capital costs are higher for gas chlorination, the chemical costs are significantly lower than when HTH or bleach is used.

## **GAS CHLORINATION**

Gas chlorinators operate under negative pressure or vacuum conditions. This is important because leaks allow air into the system instead of releasing chlorine gas, like it would if it was pressurized. A gas chlorination system consists of one or more gas cylinders connected to gas chlorinator.

The gas chlorinator has five major components. The heart of the system is the injector. It is also referred to as an ejector. The injector creates the vacuum that is needed to open the system and feed chlorine gas. A pressure regulating valve isolates the gas side of the process. A feed rate indicator, or rotameter, is used to measure the gas flow. A flow-regulating device, either a V-notch plug or needle valve, is used to adjust the gas flow. A pressure relief valve is installed to vent gas under pressure from the system.

The injector creates vacuum with a venturi nozzle and tail pipe assembly. A spring loaded diaphragm check valve assembly prevents water from backing up into the system when it is isolated. Water must pass through the venturi fast enough to create a vacuum. Chlorine will pass through the hole in the middle of the diaphragm and mix with the make-up water when the vacuum is created.

The pressure regulating valve is a spring loaded plug valve that opens when a vacuum is created and maintains a constant negative pressure inside the chlorinator. When there is no vacuum, the injector diaphragm and pressure regulating valve will close to isolate the system.

The feed rate indicator consists of a ball floating inside a glass tube. The feed rate is indicated on the glass tube and the flow units are pounds per day. The feed rate reading should be taken at the widest point of the ball or float. The feed rate is controlled using the needle valve or V-notch plug. The V-notch plug is the common feed rate valve in gas chlorinators.

If the pressure regulating valve gets dirty and doesn't seat properly, gas will enter the chlorinator under pressure when the unit is not feeding. The pressure relief vent opens and gas will pass through a hole in the pressure regulating valve diaphragm and vent to atmosphere.

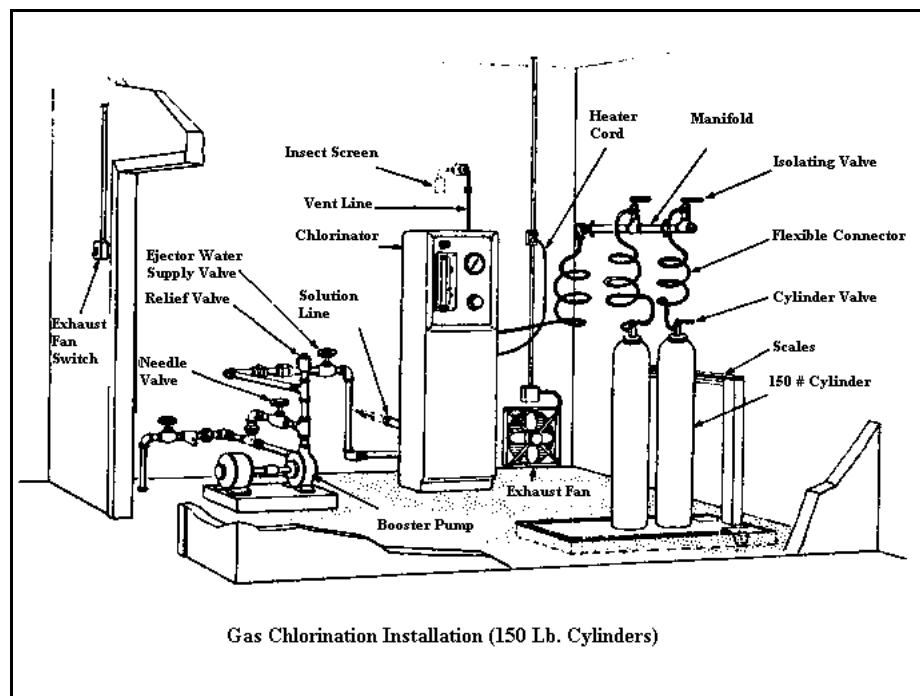

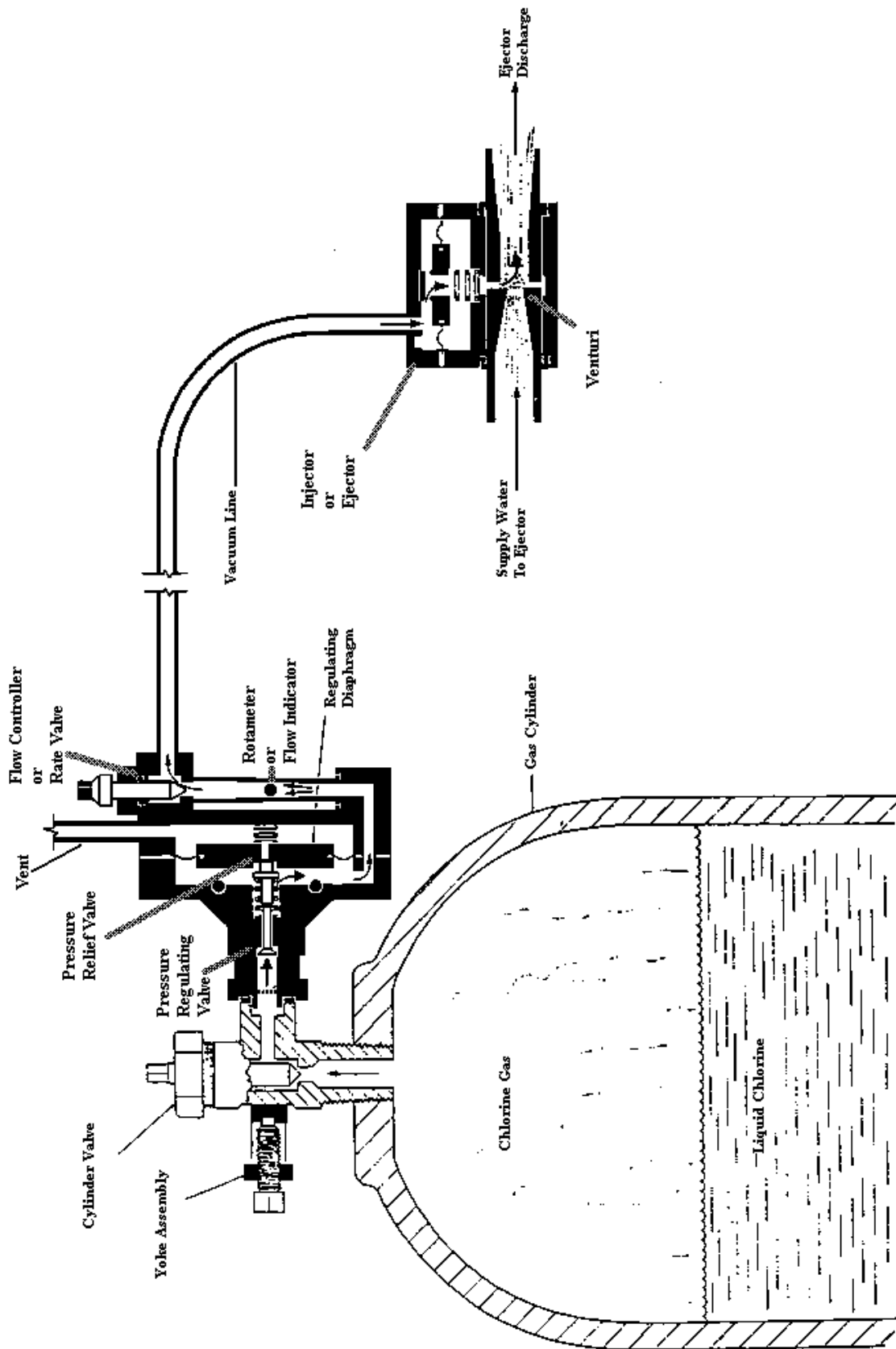

### TROUBLESHOOTING GAS CHLORINATORS

Symptom	Probable Cause
Low Feed Rate and Low Vacuum	Clogged Injector/Ejector
Low Feed Rate and High Vacuum	Clogged Gas Feed Line Closed Cylinder Valve Empty Cylinder
Feed Rate Jumps	Clogged Flow Controller/Needle Valve
Feed Rate Won't "Zero"	Dirty Flow Indicator/Rotameter
Chlorine Gas at Vent	Dirty Pressure Regulating Valve
No Vacuum	No Supply Water Vacuum Leak

The maximum feed rate for a 150 lb. Cylinder is forty pounds/day. The maximum gas feed rate for a 1-ton cylinder is 400 pounds/day. If these feed rates are exceeded, the tanks will frost over because heat can't pass through the tanks as fast as it is being used to evaporate the chlorine from a liquid to a gas. This can also occur in situations where several tanks are manifolded to the chlorinator. If one of the cylinder valves is partially closed the other tanks may try to feed too much gas and frost over. When this happens, check the tank that isn't frosted for a closed valve or plugged pigtail line.

Ton cylinders are sometimes set up to feed liquefied gas. These systems use an evaporator to boil the liquid to a gas before it goes to the chlorinator. NEVER manifold cylinders together when feeding liquefied chlorine to an evaporator. Expansion tanks equipped with rupture disks are used to protect liquid feed piping. These devices provide protection from expansion of liquefied gas that may become isolated in the line. They must be located between each pair of block valves in the piping system.

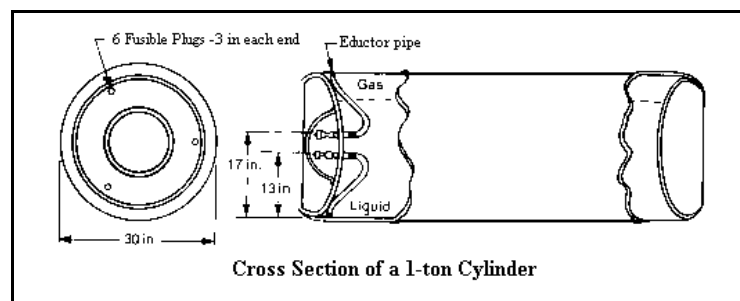

## HYPOCHLORINATION SYSTEMS

A typical hypochlorination system will consist of:

- **A solution tank holding bleach or an HTH solution.**
- **A chemical feed pump, usually a diaphragm-type pump.**
- **A tee into the well line as the point of application.**

The solution tank should hold at least a one-day supply of chlorine solution. If the solution is bleach, it will have between 6-15% available chlorine. There is about one pound of chlorine per gallon of 12% bleach. If HTH is used, add 1.5 pounds of HTH per gallon of water to achieve a one pound per gallon chlorine solution. Use breakpoint chlorination to adjust the stroke on the pump and achieve the desired dosage. Small systems may need to dilute the solution further, since the low flows may require feed rates too low for most feed pumps.

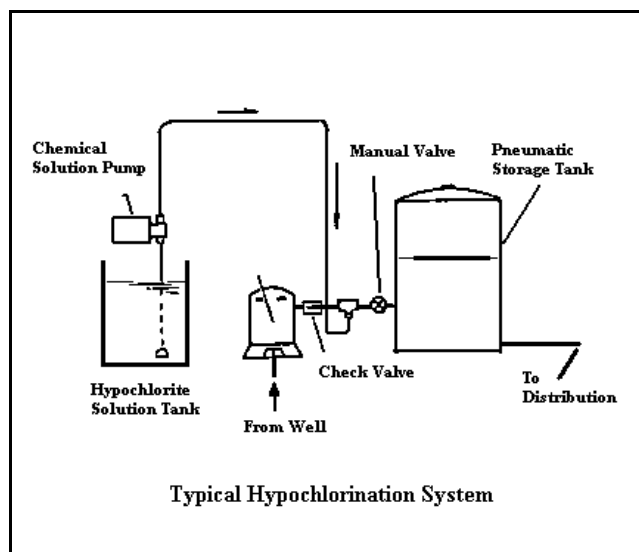

The chemical feed pump is usually a reciprocating diaphragm pump with two check valves. The check valves, that provide the one-way flow through the pump, can get clogged with lime deposits. This occurs because HTH is 30-35% calcium. The strainer on the pump suction line should be located several inches above the bottom of the solution tank to prevent lime scale and grit from being drawn into the pump and fouling the check valves.

The primary reason for reciprocating pump failure is a clogged or fouled check valve. Flushing the line with clean water or a weak acid, like vinegar, can sometimes correct the problem. In more severe cases the valves may have to be disassembled and cleaned. Always make sure the pump is properly primed before putting it back into service. Whenever possible, the pump located so that it has a positive suction head.

## **EMERGENCY RESPONSE PROCEDURES**

When gas chlorine systems are located in areas where a chlorine release might endanger the general public, the water system is responsible for developing an emergency response program.

### **COMPONENTS OF AN EMERGENCY RESPONSE PLAN**

- \* **Containment and repair of the leak**
- \* **Notification of other emergency preparedness agencies**
- \* **Evacuation plans for the general public**
- \* **Medical evacuation for casualties**

The following steps should be taken when a leak poses immediate danger to employees or the public:

- 1) Evacuate everyone, in an upwind direction, to high ground.
- 2) Once evacuation is complete, notify emergency medical units if there are casualties and begin administering First Aid to the injured.
- 3) Notify local fire and police departments and other emergency responders. Include the following information:
  - a) Nature of the accident
  - b) Approximate amount of chlorine that may be released.
  - c) Location of chlorine facility
  - d) Current wind direction
- 4) Notify County and State health agencies.

## ALTERNATIVES TO CHLORINATION

Dechlorination requirements have caused many systems to look at disinfection alternatives. The chemical costs have made other disinfection options become more cost effective. Ozonation and ultra-violet radiation are the two most commonly implemented disinfection options in wastewater treatment. They both have advantages and disadvantages.

### OZONE

Ozone ( $O_3$ ) is created when high voltage electricity arcs across an oxygen atmosphere. Ozone is created by lightning strikes or when a spark plug in a combustion engine fires. Ozone is up to 30 times better at disinfection than chlorine. It must be generated on-site and requires a tremendous amount of electricity. The corona tube system is the most common method of producing ozone. A high voltage current is introduced into a dielectric glass tube containing dry filtered air or pure oxygen. The ozone that is generated is then introduced to waste flow through diffusers. In addition to being a powerful disinfectant, ozone breaks down into dissolved oxygen which is a beneficial byproduct. As a result, there are no requirements to remove it before discharge, like there are with chlorine.

There are several disadvantages to ozone disinfection. Ozone generation is a very expensive process. When the process is down there is no backup supply available. Because ozone is such a good oxidizer and disinfectant; it doesn't last long in water. It breaks down into dissolved oxygen and has a half-life of about 20 minutes..

### ULTRA-VIOLET DISINFECTION

Ultra-violet disinfection uses high intensity UV rays to destroy pathogens. Like solar radiation, the UV rays damage the chromosomes of the organism to kill it. The efficiency of a UV system is dependent on the water clarity, contact time and bulb intensity. One of the advantages of UV disinfection is that there are no chemical by-products. While the electrical cost of UV radiation is higher than the cost of chlorination. It is cheaper than chlorinating and then dechlorinating.

One of the disadvantages to UV radiation in water treatment is that, like ozone, there is no residual. This is an advantage in wastewater treatment since no byproduct removal is required.

The UV bulbs must be cleaned periodically and replaced when their output begins to drop. Over time they will become coated with lime scale, iron deposits and biological slime. The unit will need to be acid washed every six months to keep the light transmittance high enough to achieve the proper bacterial reduction.

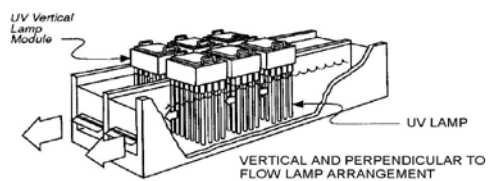
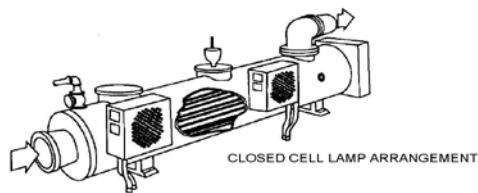

### BASIC STUDY QUESTIONS

1. What is meant by disinfection?
2. What are some of the uses for chlorine other than disinfection?
3. What is meant by the term free chlorine residual?
4. What are chloramines?
5. What is breakpoint chlorination?
6. What are the characteristics of chlorine gas?
7. What test is used for chlorine residual analysis?
4. A fusible plug melts at:
  - A. 120° F
  - B. 157° F
  - C. 188° F
  - D. 212° F
5. Calcium Hypochlorite is:
  - A. 5-12% available chlorine
  - B. 65-70% available chlorine
  - C. 100% available chlorine
6. A gas chlorinator rotameter reading is:
  - A. Milligrams per liter
  - B. Cubic feet per day
  - C. Pounds per day

### BASIC SAMPLE TEST QUESTIONS

1. Locate chlorine leaks with:
  - A. Ammonia
  - B. Bleach
  - C. Hydrochloric acid
  - D. Water
2. Chlorine gas can be lethal at concentrations as low as 50 ppm.
  - A. True
  - B. False
3. Breakpoint chlorination occurs when combined chlorine residuals have been achieved.
  - A. True
  - B. False
7. Take the rotameter reading at:
  - A. The top of the float
  - B. The bottom of the float
  - C. The widest part of the float
8. A 1-ton cylinder will have how many fusible plugs?
  - A. 6
  - B. 4
  - C. 2
  - D. 1

### ADVANCED STUDY QUESTIONS

1. What two acids are formed when chlorine gas reacts with water?
3. What are the advantages and disadvantages of ozone disinfection?
4. What is the maximum gas feed rate for a 150 lb. cylinder?
5. Which three chemicals are formed when chlorine reacts with ammonia in water?
6. What pieces of safety equipment are required on liquid chlorine feed lines?
7. What chemicals can be used to dechlorinate wastewater effluent?
4. A low vacuum in the system can be caused by:
  - A. Dirty rotameter
  - B. Clogged injector
  - C. Relief valve open
5. Liquefied gas is drawn from a ton cylinder using:
  - A. The top valve
  - B. The bottom valve
  - C. A venturi device
6. Gas coming from an outside vent line would indicate a:
  - A. Clogged injector
  - B. Dirty pressure regulating valve
  - C. Vacuum leak
  - D. Closed cylinder valve

### ADVANCED SAMPLE TEST QUESTIONS

1. The maximum feed rate for a 150 lb. cylinder is:
  - A. 10 pounds/day
  - B. 20 pounds per day
  - C. 40 pounds per day
  - D. 150 pounds per day
2. A pressure regulating valve:
  - A. Measures chlorine gas flow
  - B. Isolates the injector during shutdown
  - C. Is used to detect chlorine leaks
  - D. Isolates the gas feed during shutdown
3. Canister masks are for escape purposes only.
  - A. True
  - B. False
7. If more than 40 pounds per day are drawn from a 150-pound chlorine cylinder it will overheat.
  - A. True
  - B. False

## Dechlorination

For years wastewater treatment plant effluents have been disinfected with chlorine. In some cases, excessive amounts of chlorine were used in an effort to meet new, or get around, ammonia removal requirements that were added to NPDES permits in the early 1980s. This resulted in total residual chlorine (TRC) concentrations in the effluent that far exceeded the levels needed to kill fecal coliform bacteria.

The addition of these higher levels of chlorine proved to be hazardous to both plant life and fish in the receiving waters. Systems are now required to dechlorinate any chlorinated effluent before it is discharged into a receiving stream or lake. Sulfur chemicals are used to remove chlorine residuals.

### SULPHUR DIOXIDE GAS

The most common dechlorination chemical in large wastewater systems is sulfur dioxide (SO<sub>2</sub>) gas. It is a reducing agent that reacts with the hypochlorite ion to break the bond between the oxygen and chlorine. This neutralizes the chlorine the same way that sodium thiosulphate neutralizes chlorine in a bacteriological sample.

Although they are chemically different, sulphur dioxide and chlorine gas have many of the same handling and safety considerations. They are both heavier than air and are stored as a liquefied compressed gas. One of the differences is that sulfur dioxide is a colorless gas. They both have a pungent odor and are highly toxic if inhaled or if they come in contact with exposed tissues. Because it is stored as a compressed gas, sulphur dioxide handling safety precautions are almost identical to chlorine gas safety practices. Sulphur dioxide gas systems are called sulphonators. They operate under the same principle as a gas chlorinator. The only difference is that the maximum feed rate for a sulphonator is higher.

### ALTERNATIVES

Alternatives to using sulphur dioxide include aeration and exposure to sunlight. Aeration is not very effective because it requires continuous aeration and a very long contact time. Ultraviolet radiation also removes residual chlorine from water. Retention ponds or polishing ponds can be used to hold the effluent and expose it to UV radiation to achieve natural dechlorination.

There are other chemicals that can be used for dechlorination. One is ascorbic acid (Vitamin C) and the others are sodium bisulfite, sodium sulfite, and sodium meta bisulfite. Powdered ascorbic acid is a weak acid. It is reasonably easy to handle in its powdered form. It should be stored separate from other chemicals and kept in a cool, dry and well-ventilated room.

Sodium bisulfite is a liquid that is highly reactive. All of the sulfur chemicals are explosive if contaminated with acids and oxidizers like bleach. They should be handled with a great deal of care. The PPE requirements include respirators, face shields, goggles, chemical gloves and aprons. It should be stored separate from other chemicals. Always refer to the MSDS for both bleach and the dechlorination chemicals when handling them.

### **ADVANCED STUDY QUESTIONS**

1. Why is dechlorination necessary?
2. What are the alternatives to dechlorination with sulfur dioxide?

### **ADVANCED SAMPLE TEST QUESTIONS**

1. The chemical most often use to dechlorination wastewater effluent is:
  - A. Sodium Fluoride
  - B. Sulphur dioxide
  - C. Hydrogen sulphide
  - D. Ammonia
2. A sulphonator operates on the same principle as a:
  - A. Chlorinator
  - B. Positive-displacement pump
  - C. Lime feeder
  - D. Flocculator

## **SAMPLING AND LABORATORY**

Sampling and laboratory analysis of wastewater treatment processes are part of every wastewater treatment plant operator's daily routine. Inventories of biomass, the food coming to them, the water chemistry, the air available for them, and their metabolism rates must be calculated and recorded. There are requirements, both regulatory and operational, that dictate how and when these samples are collected, analyzed, and recorded or reported. Sampling protocols for wastewater treatment is broken down into three categories: grab samples, composite samples, and proportional composite samples.

### **GRAB SAMPLES**

Grab samples are single point real-time samples. A temperature reading or sludge blanket depth sounding in a clarifier are examples of a grab sample. A dissolved oxygen or pH reading would also be a grab sample. One of the reasons grab samples are run immediately is because the DO and pH can change over the time it takes to collect a composite sample. Microbiological samples for fecal coliform are also grab samples. Grab samples give a snap shot of a specific condition at a specific point in time or at a specific point in the system.

### **COMPOSITE SAMPLES**

Sometimes a measurement of the average across a process is important. In order to determine the total amount of solids that are under aeration in a large activated sludge system, grab samples from different spots in all of trains or stages would need to be collected in a single container. This would be a composite sample representing the entire system. A mixed liquor suspended solids test run from a sample drawn from the collected composite will represent the average concentration for the system. Even when sampling a single stage or tank, a sample should be composited from different points in the tank. Since settleometer readings and MLSS are both used to calculate Sludge Volume Index (SVI), the settleometer sample should also be taken from the composite. Other operational concerns might require grab sample settleometer readings from specific tanks during upset conditions.

### **PROPORTIONAL COMPOSITE SAMPLES**

A composite sample can also be taken over time to represent the average loading over the course of a full day. This is done when daily totals for BOD or suspended solids loading are needed. Since the influent and effluent flows change over the course of a day, representative sampling requirements dictate that smaller samples are taken at low flows and larger sample volumes are drawn as the flow increases. This is known as a proportional composite sample. Some NPDES reports require flow-proportional samples for all daily effluent BOD and suspended solids testing. Proportional composite samples for BOD must be refrigerated at 4° C (39° F). The maximum holding time for BOD analysis of a proportional composite sample is 48 hours.

## **WASTEWATER LABORATORY**

Smaller systems have fewer sampling and testing requirements. But all activated sludge treatment plants should be equipped to run pH, DO, chlorine residual, and settleometer tests. Larger systems should have equipment and personnel to run BOD, TSS, chemical oxygen demand (COD), and both mixed liquor suspended solids (MLSS) and mixed liquor volatile suspended solids (MLVSS). These tests are needed to manage and operate the plant efficiently on a daily basis. Anaerobic digester systems require testing for volatile acids and alkalinity. Tertiary nitrogen removal processes need to be able to run tests for ammonia and organic nitrogen (Total Kjeldahl Nitrogen) and nitrate nitrogen. These larger systems may also run their own fecal coliform tests. Many states require wastewater labs to be certified by the state regulatory agency. All testing must be done in accordance with "Standard Methods for Examination of Water and Wastewater" and 40 CFR 136.

## **GENERAL LABORATORY SAFETY**

There are general safety issues that pertain to all laboratory operations:

- Make sure all lab chemicals are properly labeled and have not exceeded their expiration dates.
- Make sure the SDS information on the different chemicals is available.
- Make sure that all of the personal safety gear required in the SDS data is available and employees are following those safety procedures as indicated in the data sheet.
- Combustible chemicals must be store in approved fire cabinets.
- Acids and Bases must also be stored in approved cabinets
- Some chemicals have brown glass bottles because they are light sensitive. Store them in closed cabinets.
- Be careful when handling glassware, especially when connecting glassware to rubber hoses. Use water as a lubricant to avoid injury from breakage.
- Always dilute acids and bases by pouring them into the dilution water. Adding water to an acid or base will generate a tremendous amount of heat. This will boil the water and release toxic vapors or spew hot chemicals on anyone close by. Always add acid to water to dissipate the heat.

## **SETTLEOMETER TEST**

A settleometer test is used to determine how well activated sludge MLSS are settling in the clarifier. It is used to calculate the SVI for process control and wasting sludge. A settleometer test can be performed using a 1-liter tapered cone called an Imhoff cone, a 1-liter breaker or a 1000-ml graduated cylinder. The settleometer is filled with mixed liquor and allowed to sit for either 30 or 60 minutes. As the sludge settles, its volume is recorded every 5 to 10 minutes. The final reading is recorded as milliliters. Settleometer readings will change dramatically as bioactivity changes over the course of the day. The solids inventory in the clarifier will also have an impact of the readings. If the sludge blanket is deeper settleometer readings will be lower. Always take sludge blanket readings a settleometer test is run.

The settleability of the sludge will depend on sludge age, condition and bioactivity. Settleometer readings early in the morning may be higher due to lack of food during low flow conditions. Always run settleometer tests at the same time every day. Most systems run them mid-morning after the bugs have had a chance to eat some food and reach endogenous respiration levels. Never make a process change based on a single set of settleometer tests. But if a trend persists over the course of several days, process adjustments should be considered.

## **TESTING METERS**

Dissolved oxygen and pH tests can be run using meters instead of laboratory chemical analysis. Both meters have electrodes that are filled with a fluid called an electrolyte. The electrolyte is held in the electrode by a semi-permeable membrane. The membrane allows the chemical or gas being analyzed to react with the electrolyte. This generates an electrical current proportional to the chemical strength. This current is converted to a display on the meter.

Dissolved oxygen meters must be calibrated each time they are used. They must be calibrated to compensate for atmospheric pressure and water temperature. Once calibrated, it is a simple matter to take DO readings. It is important to allow the meter time to react once it is immersed in the tank. This can take up to a minute to stabilize. If a DO reading will be high if it is taken directly over an air diffuser. Always make sure the meter probe is stored in distilled or de-ionized water when not in use. It should not be allowed to dry out. Dissolved oxygen readings must be taken as soon as possible from composited samples or biological activity may cause the values to drop.

A pH meter must be standardized before each use. They are standardized using buffer solutions of a known pH, usually 4, 7, and 10. A buffer is a chemical that neutralizes or absorbs acids and bases while maintaining a constant pH. These solutions allow the operator to correct any deviation in the pH meter by adjusting it to match the pH of the buffer solution. Fresh buffer solution should be used each time the unit is standardized. Electrodes must be rinsed with distilled water between readings. Some should be stored in distilled water when not in use. Others may require storage in a buffered pH 4.0 solution with potassium chloride added. The electrode membrane can be cleaned with isopropyl alcohol to remove slime or grease.

A field-test for pH may include color strips or indicator chemicals. Both contain chemical indicators that change color as the pH changes. A chemical indicator is a chemical that changes color when the water chemistry changes. Chemical indicators are also used in laboratory titrations for nitrogen, dissolved oxygen, alkalinity and chlorine residual.

## BACTERIOLOGICAL TESTING

Microbiological tests are conducted using one of three testing methods. The Multiple Tube Fermentation (MTF) test is also sometimes called the Most Probable Number (MPN) test. It is the oldest method for determining the probable number of coliform bacteria in a sample. It is seldom used today because it takes longer to get results and is more expensive than the other tests. The test is performed using 15 to 30 test tubes, in sets of five, which are inoculated with different decimal dilutions of the sample (10 ml/1 ml/0.1 ml). Lactose lauryl sulfate tryptose (LST) broth is used as the incubation media. The MTF sample tubes are incubated at  $35^{\circ} \pm 0.5$  C for up to 48 hours. Any tubes that produce gas are then transferred to EC broth and incubated for another 24 hours at  $44.5^{\circ} \pm 0.2$  C. Any tube that produces gas is noted and coded for each set of tubes. A table of most probable numbers is used with the coded results to determine the MPN index. The MPN table uses a geometric mean to determine the most probable number of bacteria.

The membrane filter test is easier to run and results are obtained by counting individual colonies on the filter paper. These are visible without magnification. A sample is drawn through the filter where the bacteria are trapped. The filter is then incubated in a nutrient broth at a temperature that allows the coliform bacteria to grow on the filter pad. After 24 hours, the individual bacteria that were caught on the filter will grow into colonies that can be visually counted using an optical scope. Although the procedure is similar, total coliform and fecal coliform use different nutrient media and incubation temperatures. The box below identifies the differences in the tests.

<u>Parameter</u>	<u>Total Coliform</u>	<u>Fecal Coliform</u>
Media	M-Endo Broth	M-FC Broth
Incubation Time	24 hours	24 hours
Temperature	$35^{\circ} \pm 0.5$ C	$44.5^{\circ} \pm 0.2$ C
Colony Color	Red w/Green Metallic	Blue

## MIXED LIQUOR SUSPENDED SOLIDS TESTING

MLSS testing also involves a filtration step. A sample of wastewater is filtered through a vacuum crucible. The solids in the crucible are dried for a minimum of 30 minutes to remove the moisture and weighed. The crucible must be dried to a constant weight before filtration and the sample is dried to a constant weight at 103-105° C. The term constant weight means the same weight was recorded twice in a row. The weight in grams is multiplied by the sample factor of 1,000,000 divided by the sample size to determine the MLSS concentration.

Mixed liquor volatile suspended solids or MLVSS is determined by taking the dried MLSS sample and firing it in an oven at  $500 \pm 50^\circ \text{C}$ . The ash is cooled in a desiccator and then weighed. The mg/L of non-volatile ash is calculated the same way as MLSS. The MLVSS is calculated by subtracting the non-volatile ash number from the MLSS. It is MLVSS that should be used for F:M calculations.

## **BOD AND COD TESTING**

The biochemical oxygen demand measures the amount of oxygen that the biomass uses to stabilize the organic material in the wastewater. BOD tests are either BOD<sub>5</sub> or BOD<sub>7</sub>. One is incubated for five days and the other is incubated for seven days. The BOD<sub>5</sub> test is used for calculating organic loading in the plant processes. A sample is allowed to sit in an incubator for 5 days at  $20^\circ \pm 1^\circ \text{C}$ . The amount of dissolved oxygen depleted from the sample is used to calculate the BOD strength.

BOD bottles hold 300 ml for the test. The amount of sample used in the test depends on the strength of the wastewater. If the DO at the end of the test is less than 1.0 mg/L, the sample must be diluted. This means that the only sample that might not need dilution would be a plant effluent sample. Tests on digester supernatant may require the use of less than 1 milliliter of sample in the dilution water. The diluted sample must have an oxygen depletion of at least 2.0 mg/L and a residual of at least 1.0 mg/L for the results to be valid.

The dilution water must be de-ionized to remove chemicals that might inhibit the biological processes. Micronutrients like magnesium, iron, and phosphate are then added to it to improve the biological activity during the test. Samples are run in pairs with one bottle containing only dilution water, unless samples are seeded. Tests on disinfected effluent will have to be seeded with raw sewage to replace the bugs that were killed during disinfection. The sample must also be dechlorinated using sodium sulfite, since chlorine will inhibit bioactivity. A seed blank will also need to be run in addition to the BOD test. The uptake of oxygen that results from decomposition in the seed portion will have to be subtracted from the total oxygen uptake in the BOD test.

The chemical oxygen demand (COD) test is sometimes used in larger systems as a process control test instead of using BOD results. The COD test uses acids to chemically digest the organics in the sample. It will result in higher numbers than the BOD results, but the test can be run in about 3 hours. This means that the results of a process change can be determined the same day instead of waiting 5 days to find out. When COD results are compared to BOD results, a correlation can be established that can be used to approximate the BOD strength for daily process adjustments.

### **BASIC STUDY QUESTIONS**

1. What are some of the issues related to storage of laboratory chemicals?
2. Which tests are run with grab samples?
3. How do you determine the results of a membrane filter test?
3. What must be done to a chlorinated effluent BOD sample?
4. Which media are used for total and fecal coliform membrane filter test?
5. What is the advantage of using a COD test for process control?

### **BASIC SAMPLE TEST QUESTIONS**

1. The chemical that changes color during a pH or alkalinity test is called:
  - A. A buffer
  - B. An indicator
  - C. An acid
  - D. A micronutrient
2. How do you lubricate a rubber-to-glass connection?
  - A. Water
  - B. Light machine oil
  - C. Vegetable oil
  - D. Hydrochloric acid
3. A pH meter should be standardized every:
  - A. Day
  - B. Week
  - C. Shift
  - D. Use

### **ADVANCED STUDY QUESTIONS**

1. What must be added to BOD dilution water?
2. What is a buffer?

### **ADVANCED SAMPLE TEST QUESTIONS**

1. Fecal coliform tests are incubated at:
  - A. 20° +/- 2 C
  - B. 35° +/- 0.5 C
  - C. 44.5° +/- 0.2 C
  - D. 103-105° C
2. The maximum holding time for a proportional composite BOD sample is:
  - A. 24 hours
  - B. 48 hours
  - C. 72 hours
  - D. 96 hours
3. MLVSS samples must be ignited at:
  - A. 35° C
  - B. 135° C
  - C. 255° C
  - D. 500± 50° C
4. Fecal coliform colonies in the membrane filter test are:
  - A. Red
  - B. Blue
  - C. Green
  - D. Black

## WASTEWATER COLLECTION SYSTEMS

Wastewater collection systems are used to collect and transmit liquid wastes to a central treatment facility. Like a distribution system for water supply, the collection system resembles a tree that branches out from the treatment plant to collect the wastewater from across the system. Wastewater from individual homes enters the collection system through a service line. These services attach to a lateral line with a wye connection or a tap and saddle connection. Branch lines or laterals usually run down the residential streets collecting the flow from individual services. They, like tributaries in a watershed, flow into larger lines called mains. Mains intersect to form the largest lines in the system called trunk lines. A trunk line is a transmission line that doesn't have any mains branching off of it. It is the pipe that brings water into the treatment plant. This line is also referred to as the outfall.

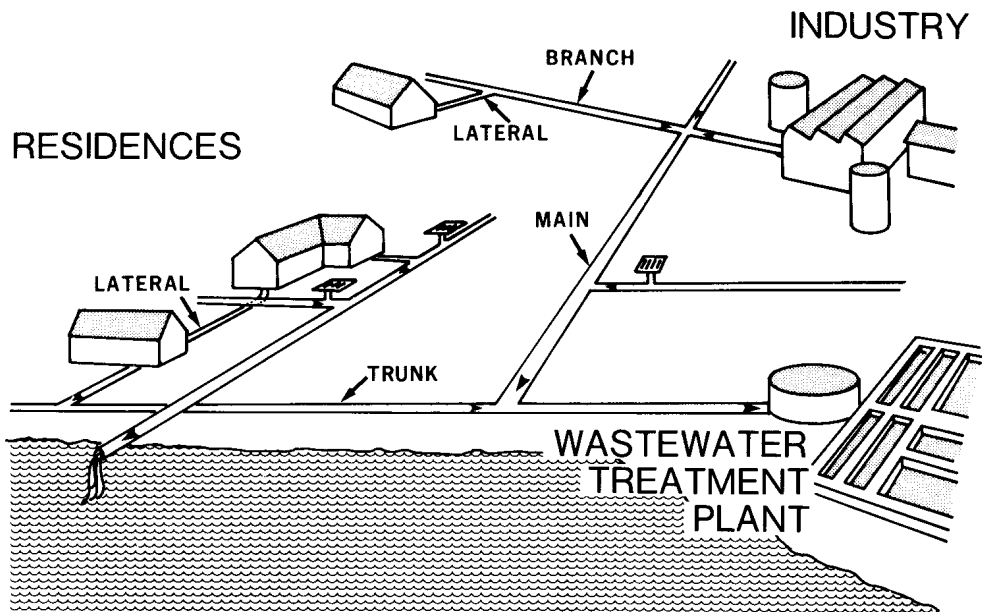

### Wastewater Collection System

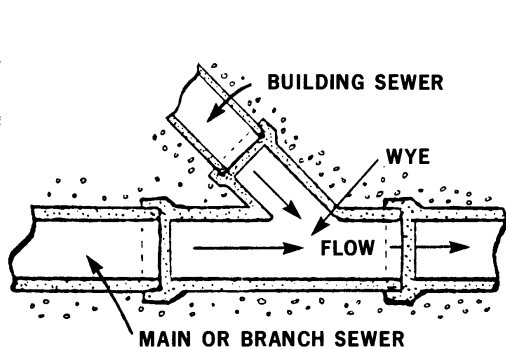

**Wye Service Connection**

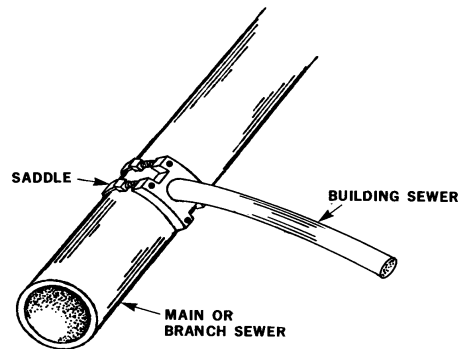

**Tap & Saddle Service Connection**

Manholes are installed in sewer lines whenever two lines intersect or there is a change of direction, elevation, or slope of a line. They provide access to the system for cleaning, inspection, and clearing stoppages. Although they should be large enough to enter and work in, they can contain hazardous atmospheres that can endanger workers. With today's modern equipment, most sewer line maintenance tasks can be accomplished without entering the manhole and putting workers at risk.

Collection lines are installed with a downhill slope that allows the flow to move through most of the system by gravity. This minimizes the amount of pumping that must occur to get the water to the treatment plant. The slope must be adequate to maintain a velocity of at least 2 feet per second in the line. This is known as the scouring velocity. When the sewer lines reach a certain depth the flow must be lifted so that it can begin flowing by gravity again. Lift stations are built whenever wastewater must be pumped to a higher altitude, whether it's to lift water up so that it can gravity flow again or to pump it over a change in topography or a hill.

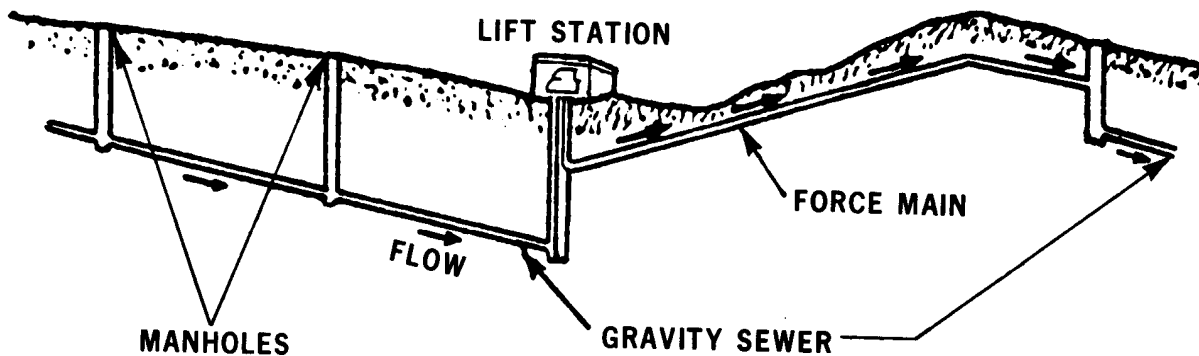

### **Lift Station and Force Main**

Collection systems must be designed to handle peak flow conditions. The size of the pipe, the type of pipe, and the downhill grade of the line determine the amount of flow that a line can handle. The average per capita flow that is used to size the system is usually about 100 gallons/person/day. Infiltration and inflow are also concerns when designing a collection system. Infiltration occurs when groundwater enters the system through broken pipe or leaking joints in wet weather. Inflow enters the system directly. It may come from runoff that floods streets and enters through submerged manhole covers or illegal service connections that direct storm flows into the system. Exfiltration occurs when sewage leaks out the pipe into the surrounding soil. Systems can gain some control over inflow and infiltration through local sewer use ordinances.

Sanitary sewers carry wastewater to treatment facilities. Storm sewers carry storm water runoff to the receiving body. Although storm water is usually low in BOD, the initial flow can contain high concentrations of suspended solids in the form of grit and dirt.

## WASTEWATER PIPING

The most common type of wastewater piping is vitrified clay pipe (VCP). It is made of fired clay and is constructed with bell and spigot connections. The spigot end of the pipe will have a rubber gasket bonded to the outside of the pipe. It creates a watertight seal for the joint. VCP has sufficient strength to withstand most trench loads and is almost impervious to corrosion caused by acids that form when sewer gases are generated. VCP is available from 4" to 36" in diameter. It is very heavy in sizes above 18".

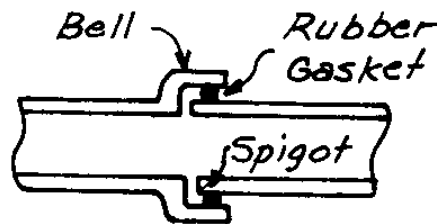

**Bell & Spigot Joint**

Reinforced concrete pipe (RCP) is used for larger lines from 18" to 60" in diameter. It is lighter than vitrified clay pipe. Concrete pipes can have bell and spigot connections. They can also have mortise and tenon or Burtnett joints that still have a big end a little end and are sealed with a rubber gasket or mastic compounds. The problem with concrete pipe is corrosion of the inside of the pipe at the top, or crown area, caused by sewer gases and organic acids.

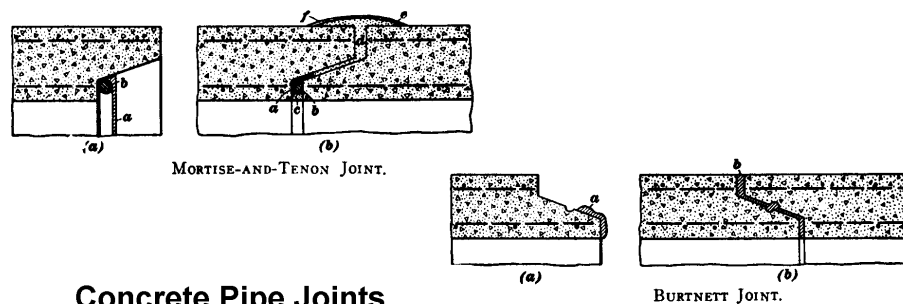

**Concrete Pipe Joints**

Cast iron pipe (CIP) or ductile iron pipe (DIP) are only used in collection systems for specific applications. They are used in areas where high trench loading exists like crossing under a railroad track or a dirt road that carries heavy equipment. Watertight cast iron pipe is also used for inverted syphons where collection lines run under roadbeds or streams. It may also be required if sewer lines pass too close to public drinking water facilities. Iron pipe is also subject to corrosion from sewer gases.

Acrylonitrile butadiene styrene (ABS) pipe is a plastic pipe. It is lightweight and flexible. It is impervious to corrosion from sewer gases, acids and bases, and inorganic salts found in wastewater. It is softened by petroleum products, which are not normally found in domestic wastewater. It can't withstand heavy trench loading. Polyvinyl chloride (PVC) piping is also lightweight and easy to install. Petroleum products do not affect it, but trench loading is still a problem. It has replaced VCP or ABS piping for residential laterals and small mains.

## MANHOLES, CLEANOUTS, AND INVERTED SIPHONS

Manholes should be spaced no more than 400-500 feet apart in straight runs of pipe. The limiting factor is that most cleaning equipment will not have more than 500 feet of rod or hose on the unit. They should also be installed anywhere pipes intersect or there is a change of direction or grade. They are normally constructed of either brick or pre-formed concrete cylinders. In areas where groundwater infiltration is a problem, they can be made from fiberglass reinforced polyester rings.

A base is poured that is at least 1 foot larger in diameter than the manhole rings to support the loads that occur when vehicles drive over the manhole cover. If it cannot support the load and the manhole settles the piping at the manhole may be fractured. Most manhole rings are at least 4 feet in diameter to allow access and room to work inside them. They are stacked on the base and grouted to prevent infiltration.

An eccentric cone is placed on top of the manhole that narrows the opening to the size of a manhole cover. An iron cover ring is then placed on top of the cone and the cover sets inside the ring. The ring and cover must be flush with the pavement so that it doesn't present a hazard to traffic. When streets are re-paved, adjustment rings are used to bring the cover back up to grade. For distances of more than 6 inches, the cone ring should be removed and additional manholes rings added.

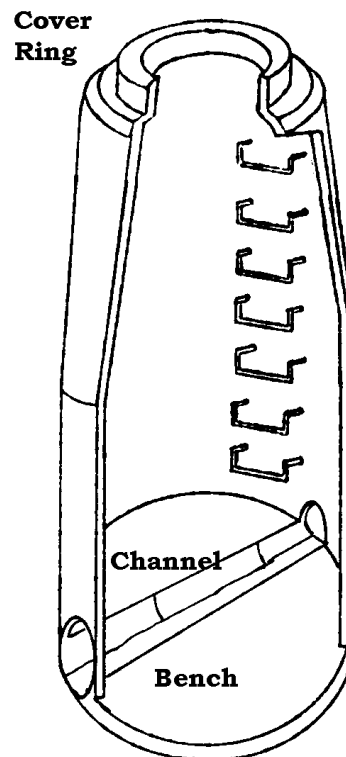

**Typical Manhole**

The base of the manhole is formed into a channel and bench. The bench on either side of the channel is flat but sloped toward the channel to insure drainage. Covers with multiple holes should not be used in low-lying areas or where streets are not properly crowned to drain runoff away from the covers.

Drop manholes are used when two sewer lines intersect at different elevations or when the velocity in the line gets too high. Velocities in sewer lines should not exceed a maximum of 10 feet per second or the scouring action of the grit in the flow can erode the piping.

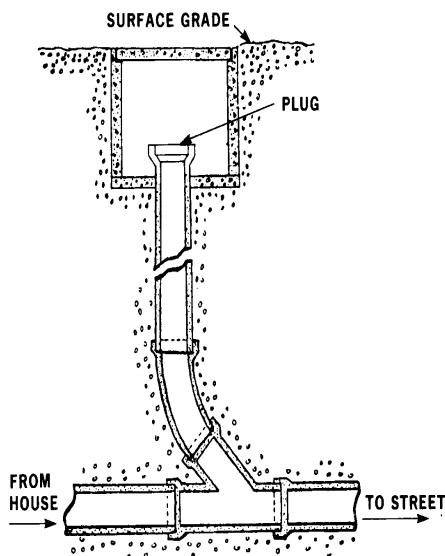

**Sewer Service Cleanout**

Cleanouts are installed on service lines and sometimes at ends of laterals instead of a manhole. They are installed for economic reasons. They cost 1/6 as much as a manhole. They allow access for some but not all types of cleaning equipment.

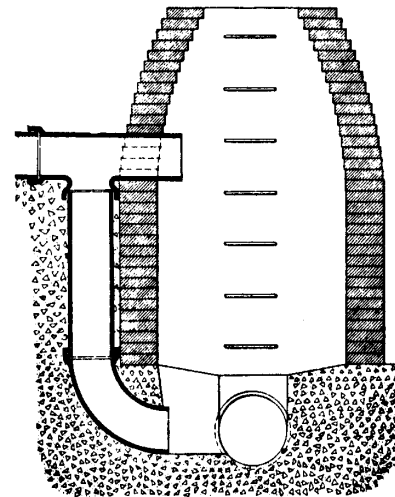

**Drop Manhole**

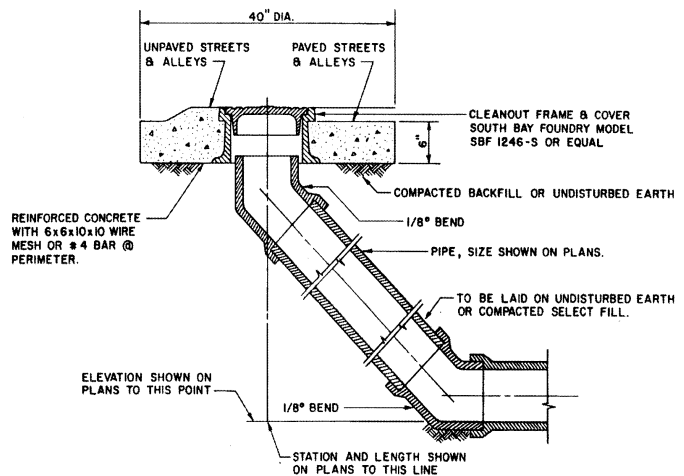

**Sewer Main Cleanout**

## INVERTED SIPHON

Inverted siphons are used when the line must drop below grade to pass under an obstacle like a roadway or streambed. Inverted siphons are difficult to clean and rely on higher velocities created by smaller piping to remove grit and debris that may accumulate during low flow conditions. The siphon line will be a smaller watertight cast ball and socket iron pipe. The smaller pipe will need to create a velocity of over 2 fps at low flows.

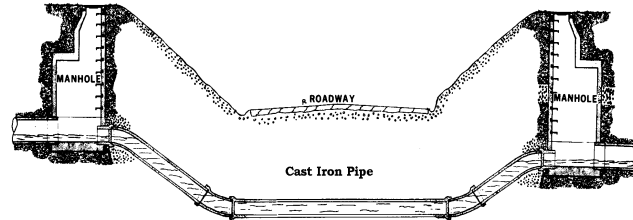

**Inverted Siphon**

## SERVICES

Service lines from residential customers must be properly installed. Improper installation can result in backups in the customer's plumbing or stoppages in the main. Service lines must slope at least 1% or 1/8" per foot so that the velocity is sufficient to carry solids to the main.

Crooked services or services with uneven grades are difficult to clean and can create conditions that allow debris to collect in the line. Bad joints that leak can be a source of infiltration and root intrusion into the service and the main.

Service connections are made using a pipe wye connection, installed when the main is laid, or a saddle and tap into an existing line. This method provides the best possible structural integrity in the line and prevents obstruction that can be caused by intrusion.

Saddle taps are attached to the main by drilling a hole in the main and attaching a saddle. The saddle has a connection for the service line that will prevent intrusion into the pipe. When a tap hole is drilled, it is important to remove the circular piece of the main, known as a coupon, so that it doesn't cause a stoppage downstream. Concrete should be poured around the tapping saddle for support.

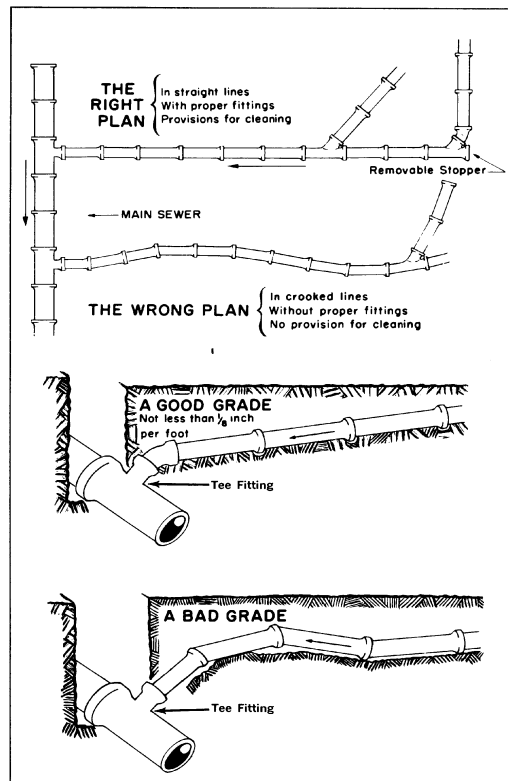

If the service line is simply inserted into a hole in the main, it will intrude into the line and increase the possibility of creating a stoppage. It will also create a problem for cleaning equipment. This connection may also leak allowing root intrusion into the line and infiltration.

## **COLLECTION SYSTEM CONSTRUCTION**

Sewer lines are usually laid deeper than water lines. They can run as deep as thirty feet before lift stations are needed. This means that trenching and shoring issues are much more complex than excavations for water lines. Trenching and shoring safety issues are addressed in Chapter 16. Trenches fourteen feet or deeper must have shoring systems that are designed by a professional engineer. Prior to digging, always get other utilities to spot their lines first. Most states have a blue stake or one-call system established for utility location. Traffic control must be established and area residents should be notified of construction and any interruption of service that could result before excavation begins.

Wastewater collection systems are designed to have water flow downhill by gravity. The only time pumps are used is when the flow needs to be lifted so it can flow by gravity again. A downhill grade or slope must be established in order to maintain a certain velocity in the piping. Sewer lines are more difficult to install because the pipe must be laid straight and the slope of the pipe must remain constant. The line must be straight so cleaning equipment can pass through it. Changes in slope or grade can lead to solids settling in the low spots.

Many operators are not directly involved in the installation of collection system piping. Knowing how to correctly and safely installing these lines is important because operators may be responsible for the inspection of a contractor's work or making repairs on existing lines.

## **HANDLING PIPE**

Water piping should always be handled with care. Although it is inspected before it leaves the factory, damage can occur during shipment. Always check all pipe materials, gaskets and fittings before accepting a shipment of pipe. Vitrified clay pipe is checked by tapping sections lightly with a hammer. A pipe that is not cracked will make a faint ringing sound. Cast iron pipe can be checked using the same technique. PVC pipe is checked for discoloration. Discolored pipe has been damaged by ultra-violet radiation.

Piping should be unloaded in the area where it is to be installed. It is usually placed along the side of the trench. It should never be moved using a backhoe bucket or blade. Proper rigging and slings should be used to safely move heavy iron or concrete cylinder pipe sections. Store all gaskets and fittings that can be removed indoors where they will not become damaged from exposure and sunlight.

## EXCAVATIONS AND UTILITY LOCATION

It is important to remember that the collection system is not the only utility located in or near the street. The statewide “Blue Stake” number should be called to get the other utilities spotted before the trenching operations begin. Failure to request line spots for other utilities will make the system responsible for any loss of service or product and the cost of repair if they are damaged.

Excavations for sewer lines must be dug to grade. The depth of the line may vary with changes in surface contours. Plan and profile maps are used to determine the correct location and depth of the line. A plan view is a view from above. It is used to determine the location of the line and major components of the system. These are put together to create the section maps that maintenance crews use for line and manhole location.

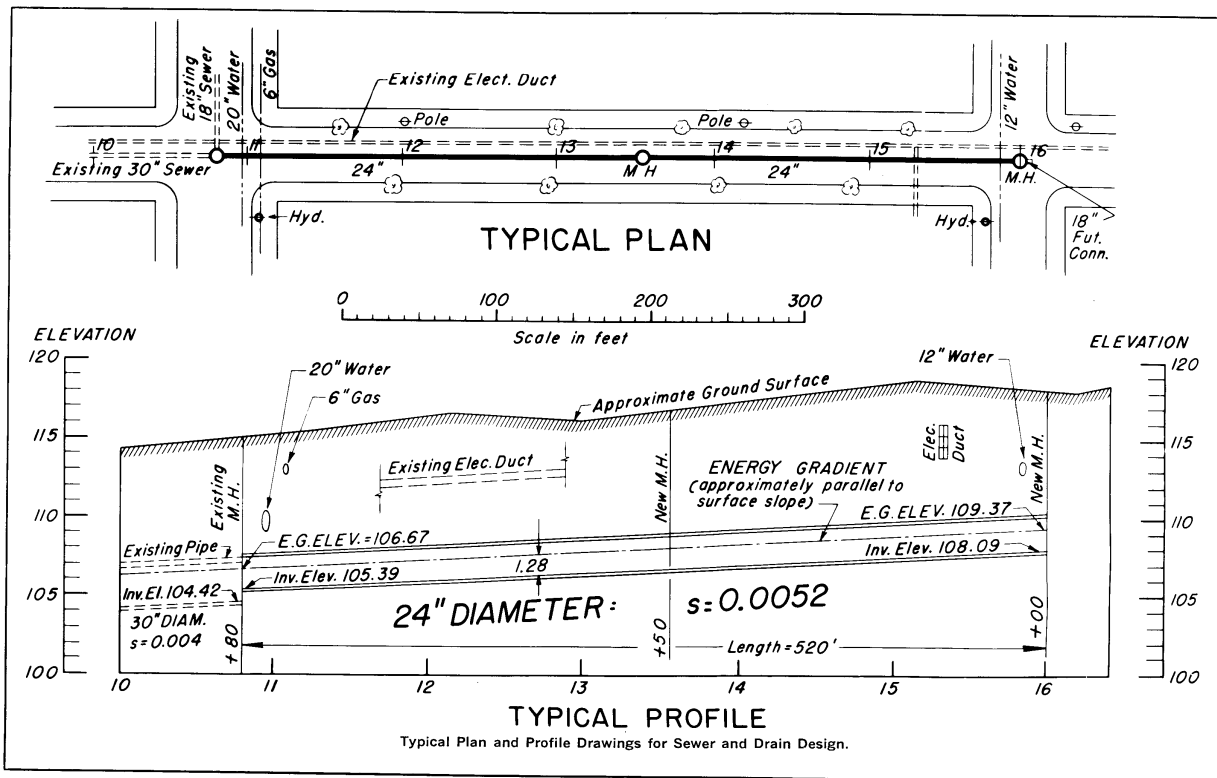

A profile view is a side view showing the soil contours and depth of the line. Distances are identified from a reference point as stations. The section of pipe shown begins at 10+80 or 1080 feet from the reference point and ends at 16+00 or 1600 feet from that point. If we subtract the run of pipe is 520 feet long.

## PIPING GRADES

The downhill slope of the pipe must be adequate to maintain a 2 foot per second velocity. At 2 fps, the grit and heavy inorganic solids will not settle out in the lines and cause stoppages. Odor and corrosion problems are also more prevalent in lines where slopes are not adequate to maintain minimum velocities.

The slope of a line is calculated by dividing the rise (or drop) by the run or length of the line. For instance, if a run of pipe is 400 feet long and it drops 1 foot, the rise over the run is  $1/400$  or 0.0025. It would also be a 0.25% slope. It is important to make sure the grade is constant.

There should not be deviation above or below the grade line. The pipe is laid so that the invert, or inside bottom of the pipe, is at the proper slope. It is identified as the invert elevation. The inside top of the pipe is known as the crown. The bell ends of the pipe must be laid facing upstream.

Grade stakes and string lines or laser systems can be used to establish the proper grade during construction. String lines are established at the proper slope above the trench. Grade rods are used to check the invert elevation of each section of pipe. Laser systems shoot a beam down the inside of the pipe just above the invert of the pipe. This method is more precise than the string line method.

Once trench is excavated to the proper grade the trench floor must be leveled. Notches are dug in the floor of the trench where the bell end of each section of pipe is located. When water lines are encountered during construction the water line should always be relocated to avoid changing the grade of the sewer line. When a sewer line crosses over a water line, the sewer line should be cast iron pipe for 50 feet on either side of the intersection. Lines that must pass under roads or railroad tracks can be bored. But the line must be encased in cast iron or concrete. This maintains the proper grade and proper support for the piping.

### Laying Pipe to Grade

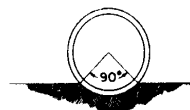
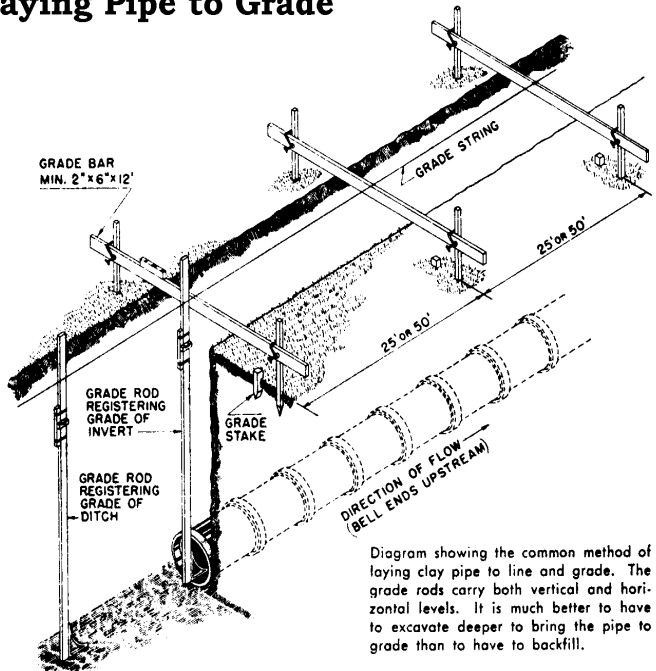

The lower 90 degree arc of the barrel of the pipe should be in firm contact with undisturbed earth.

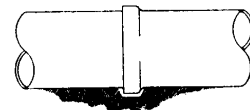

Small excavations should be made for the bells. These should be no larger than necessary to clear the bell.

Most pipe sections have either a bell and spigot or a mortise and tenon joint. Rubber gaskets are used seal the connection. These pipe sections must be pushed together against the resistance of the gasket. When pushing pipe sections together, either by hand or with heavy equipment like a backhoe, a wooden block is placed between the bar or bucket and the pipe end. This blocking method is used to avoid damaging the pipe. Gaskets should be lubricated with grease to aid in making the connection.

## BEDDING PIPING

Bedding material is used to support and protect the pipe from trench loads and pressure points. Bedding material should be free of large or sharp rocks. Sand is an excellent bedding material because it compacts around the pipe well and provides excellent support. If bedding materials are not used beneath the new piping, the trench floor must be prepped to support the piping properly. The floor of the trench must be level and free of any protruding rock. Indentations must be dug under the bell ends so that they do not act as the support for the section of pipe. Improper bedding will result in broken joints that leak or collapse.

Special bedding material may be required when heavy trench loads are encountered. Class "A" bedding is concrete that is used to encase the pipe. It may be also be used when inverted siphons go under steams or ditches.

Class "B" and "C" bedding are granular materials like gravel and sand. They would be used for bedding plastic pipes and VCP and concrete pipe in high load areas that don't require concrete bedding.

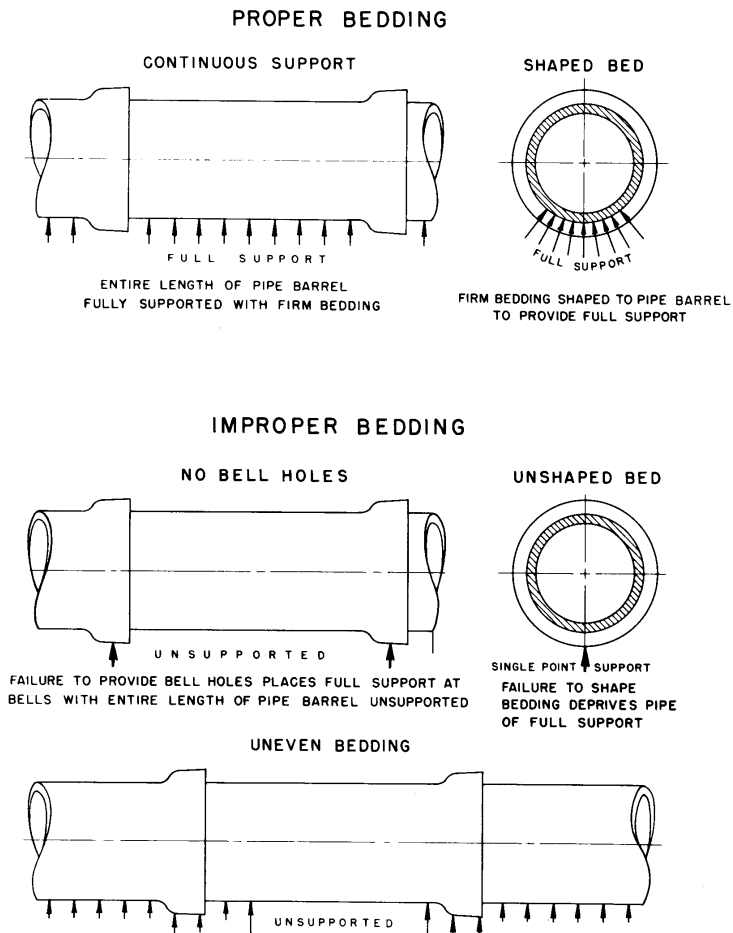

## BACKFILL CONSIDERATIONS

The type of backfill material used is also a very important factor in the protection of all pipes. This is especially important when PVC pipe, with its poor load bearing capability, is used. PVC piping should never be used under high load areas like highway or railroad crossings. If rocks or other abrasive material are present in the backfill, a sharp edge may create a single point of stress against the pipe wall. This can lead to misaligned or broken joints and structural collapse. To prevent this kind of damage from happening a select backfill material should be used.

The backfill should be carefully added and properly tamped to help support trench loads. The backfill material should completely surround the pipe. It should be tamped when the pipe is still half exposed and again when the pipe is covered by about 6 inches of material. After the pipe is covered, backfill and compaction should be done in 12-18" lifts or layers that are tamped.

If the trench is filled completely before it is tamped, settling will occur. This will greatly increase the stress on the pipe as continuous loading from traffic occurs. This is also the reason why trenches should be cut narrow as possible. Wider trenches result in increased load stresses on the pipe.

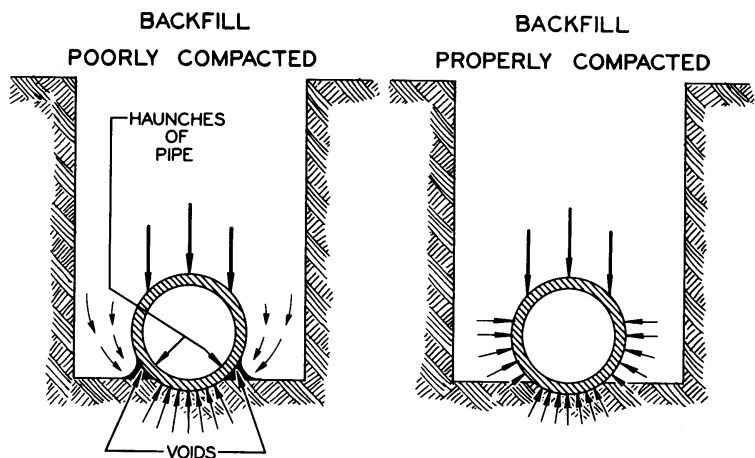

VOIDS, OR POORLY COMPACTED BACKFILL AT HAUNCHES, CAUSES SUBSIDIENCE OF THE BACKFILL AT SIDES OF PIPE AND SUBSEQUENT LOSS OF SIDE SUPPORT.

PROPERLY COMPACTED BACKFILL PROVIDES SIDE SUPPORT FOR PIPE.

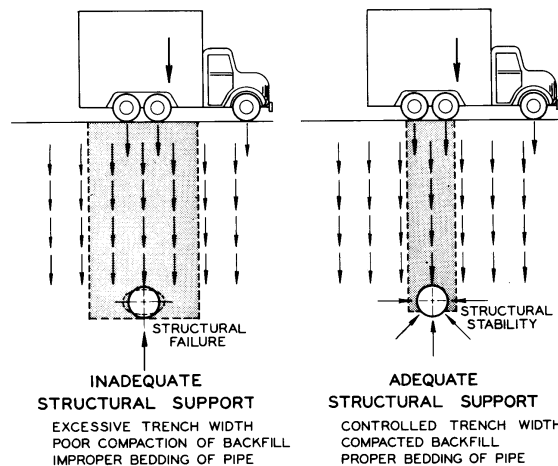

INADEQUATE STRUCTURAL SUPPORT  
EXCESSIVE TRENCH WIDTH  
POOR COMPACTION OF BACKFILL  
IMPROPER BEDDING OF PIPE

ADEQUATE STRUCTURAL SUPPORT  
CONTROLLED TRENCH WIDTH  
COMPACTION OF BACKFILL  
PROPER BEDDING OF PIPE

## TESTING AND INSPECTING SEWER LINES

Testing and inspection of the collection system piping is necessary to insure that new lines are installed correctly and to check existing piping for damage or corrosion. Testing may also be a means to identify sources of inflow or infiltration from broken lines or illegal connections.

### TESTING SEWER LINES

There are three tests that are performed on sewer lines. Dye testing, pressure testing and smoke testing are done to assess the general condition of the piping. While there are other means of inspecting piping, like closed-circuit TV, these tests are relatively easy to do and can give a quick indication of whether a closer look should be taken with a CCTV unit.

#### DYE TESTING

Dye testing is used to determine if drains are connected to the sewer system. It can be poured down a patio drain, which should not be connected to the sanitary sewer, to see if the dye appears at a downstream manhole. It can also be used to estimate the flow velocities in a pipe. When dyes are used to determine velocity in a pipe the results will normally be 10-15% faster than the actual average velocity. This is because the flow through the center of the pipe moves faster than the flow at the edges where friction with the pipe wall is encountered. The friction will cause dye marker to become elongated as it moves down the line. Add half of time the dye was visible to the time it took to first appear to get a more accurate velocity reading.

#### PRESSURE TESTING

Pressure testing is usually done during new pipe installation. It should be part of the acceptance criteria for the installation. If a line is not able to hold pressure infiltration from groundwater may be excessive. The line is plugged at both ends and air is pumped in until the pressure reaches 3.5-5 psi. When the air pressure has stabilized, the airflow is turned off. The pressure will begin to drop. The length of time it takes to drop from 3.5 psi to 2.5 psi is used to determine whether the pipe meets the criteria. A calculation is used to determine the acceptable time for the pressure drop.



**Inflatable  
Piping Plugs**



There are serious safety issues that must be addressed when using inflatable plugs in sewer lines. A great deal of force can build on the end of a pressurized plug. If it fails and blows out of the line, the energy behind it can cause serious injury to anyone in the way. No one should be allowed in the manhole when one of these plugs is in the line. They are designed for insertion and removal without entry into the manhole. Always secure the plug with a lanyard so that it can be retrieved. Anytime a manhole must be entered there are confined space safety concerns that must be addressed.

## SMOKE TESTING

Smoke testing can be done on new or existing lines. A blower is used to blow smoke into a manhole and down the lines. Restrictions are placed in the pipes to bottle up the smoke in the section to be tested. Traffic cones are sometimes used as a restriction, since they allow flow through them while blocking most of the pipe. A blower and smoke cartridge are set up to blow air and smoke through the lines. After several minutes, the area is canvassed to identify locations where smoke is found coming up from the system.

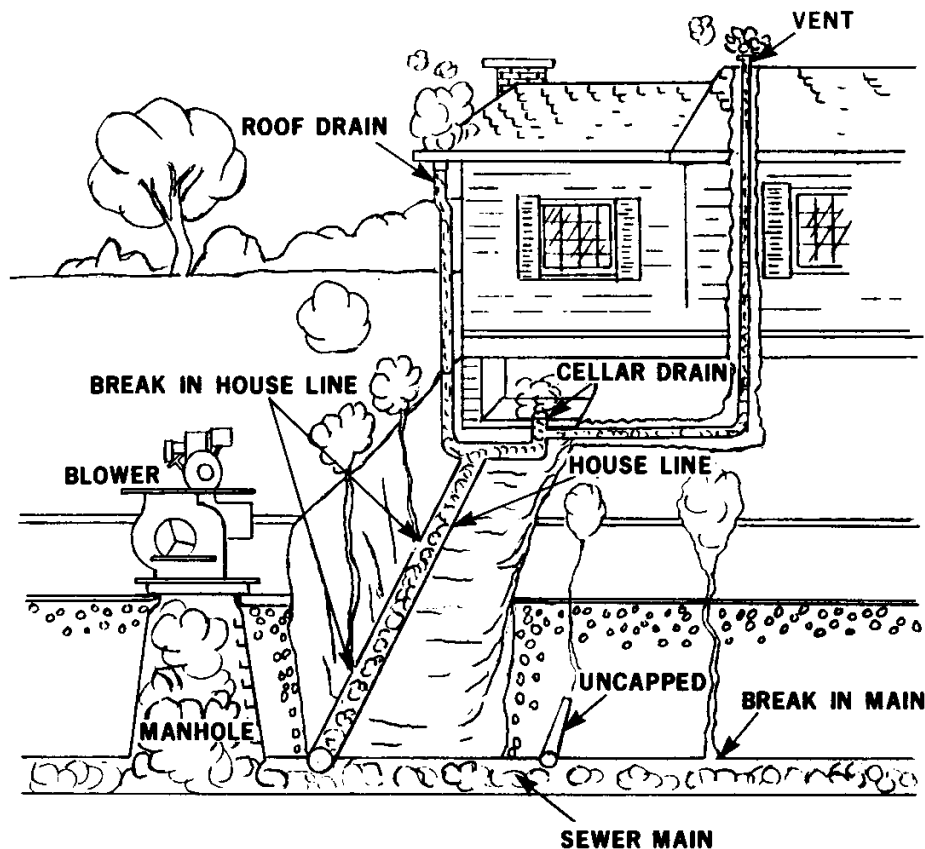

# Smoke Testing

Smoke should be found coming from residential roof vents and cleanouts. If it is found coming from gutters or patio drains, it indicates an illegal tap. Those drains should be reconnected to a storm sewer. If smoke surfaces in the street or residential yards it means there is a broken line. It may come up from a residential floor drain. This means the P-trap is dry. This situation can lead to harmful sewer gases collecting the customer's house. They should pour a quart of water down the drain every three months to maintain the water seal.

Before conducting a smoke test always make sure to notify the residents, the fire department, and the police department when and where the test will take place. Smoke coming up from the basement of a house can cause panic for the homeowner and result in 911 calls. It can be embarrassing to have fire trucks respond to false alarms due to inadequate communications.

### CCTV INSPECTION

A closed circuit TV unit runs a camera down the line to televise and videotape the condition of the pipe, pipe joints, grade, and service connections. It can be used to identify cracks in piping, offset or broken joints, grease, and root intrusion while documenting the condition and location of the problem. These units consist of a van or trailer that has a generator, cable spool and winch, camera unit, and video tape recorder. Older units have a winch assembly that is mounted at the end of the line and is used to pull the camera through the line. The winch on the truck was used to retrieve the camera after the inspection was completed. Newer units have a self-propelled camera that is equipped with a set of tank-like treads or all-terrain tires that allow it to move by remote control without the need for a winch system. Most new cameras have a rotating lens that can be positioned to look up into service taps and inspect joints on the line.

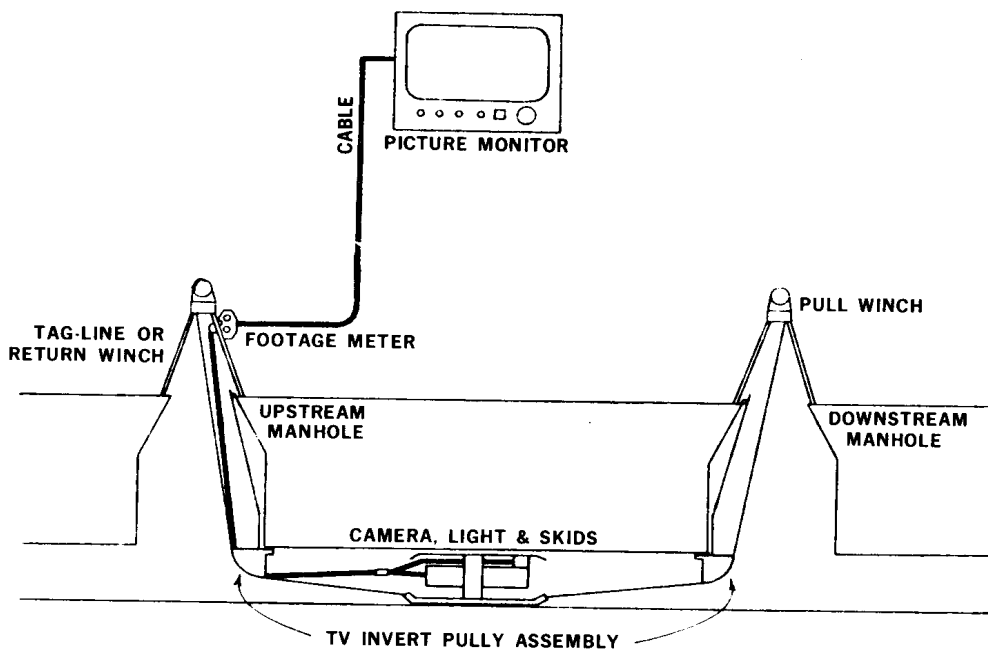

**CCTV Equipment**



### **Tracked and 4-Wheel Drive Camera Systems with Rotating Camera Heads**

The line should be cleaned with a jet cleaner prior to the inspection. The jet unit can also be used to string the cable for the winch systems. The camera system is designed to allow placement and retrieval of the unit without entering the manhole. Care must be taken when the unit encounters offset joints in the pipe or collapsed lines. These are places where the camera can get stuck.

## **PROBLEMS IDENTIFIED BY CCTV INSPECTION**

CCTV inspection can be used to locate and identify a number of conditions in collection systems that can lead to stoppages. Whenever a stoppage occurs a CCTV inspection should be conducted after it is cleared to try and identify the cause of the problem. There are several reasons why stoppages occur at certain locations. Some stoppages are caused by structural problems. Others are a result of materials in the sewage flowing in the pipe. Grease and grit can both create conditions that result in stoppages.

### **STRUCTURAL PROBLEMS**

Taps that protrude into the line are likely to catch debris. When certain types of cleaning equipment encounter protruding taps the line and the tools may be damaged. Misalignment of the piping is another structural problem that can be identified by CCTV inspections. Misalignment at pipe joints is usually a result of improper bedding or trench loading failures. Misalignment can be vertical or horizontal. Vertically misaligned joints are identified as a drop or jump and horizontally misaligned joints are referred to as left or right offset.

The camera can also be used to identify changes in the slope of the piping. When the depth of the water in the line changes it indicates a change in the grade of the pipe. When the water gets deeper the invert has dropped below grade. When it runs shallow the invert is above grade. Infiltration at leaking pipe joints can also be identified by televised inspection. Infiltration from saturated soils can create hydraulic overloading of the treatment facilities. Leaking joints can be sealed with watertight grout. If they are not sealed, root intrusion will likely occur at the leaking joints. CCTV units are also used to properly locate packing equipment used to seal joints in the pipe.

### **ROOTS, GREASE, AND CORROSION**

Root intrusion is a major concern for collection system operators. Tree roots that find their way into sewer lines through leaking joints or customers' service lines can cause chronic stoppage and backup problems. Roots must be cut to clear the line. The problem is that cutting roots is similar to pruning shrubs. If the tip of a root is cut it splits into two branches. Misaligned joints or leaking joints that allow root intrusion must be fixed. Services that allow root intrusion are an issue because it is the customer's responsibility to maintain the service line. As the root mass grows it can create enough pressure to cause piping failures

**Severe Root Intrusion – Right  
Grease Buildup - Bottom**

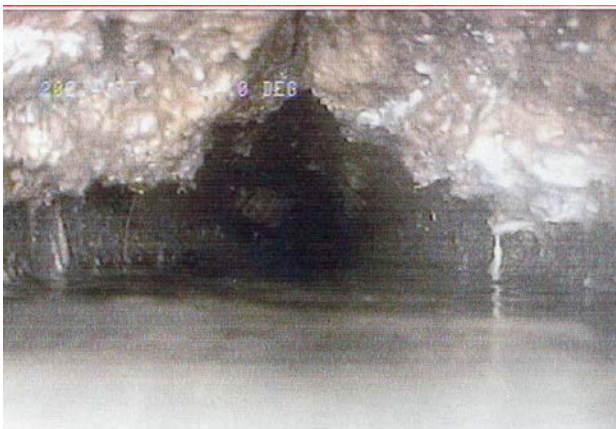

Lines that carry large amounts of grease may cause backups when it accumulates on the crown of the pipe. The result is that the carrying capacity of the pipe is greatly reduced. The source of the grease should be located. It is almost always a restaurant or food processor. They should have their grease interceptor inspected and cleaned.

Corrosion in sewer lines can be the result of chemicals from industrial discharges. It is more commonly caused by septic conditions that release hydrogen sulfide gas ( $H_2S$ ). Sulfuric acid is created when the hydrogen sulfide gas reacts with the moisture on the inside of the pipe wall. This can cause serious corrosion problems in large concrete cylinder piping. It is less of an issue in vitrified clay pipe. Acids do not affect PVC pipe. Aeration in lift station wet wells and the addition of chlorine in the collection system are two ways of minimizing hydrogen sulfide production.



**Crown Corrosion in a Concrete Pipe  
Hydraulic Jet Cleaner in the background**

Crown corrosion will compromise the load carrying capacity of concrete piping. Once the structural integrity is compromised, plans should be made to rehabilitate the pipe by slip lining the pipe. Cast-in-place-pipelining will protect the pipe from further corrosion but will not provide any additional structural support.

## BALLS AND KITES AND SCOOTERS

Some of the first equipment designed to clean sewer lines utilized the scouring action of water passing around an object that was slightly smaller than the pipe. Head pressure was developed behind the device by adding a large volume of water upstream and creating a backup of several feet of head. The problem with doing this is that there is always a risk of flooding homes between the flushing manhole and the ball/kite/scooter.

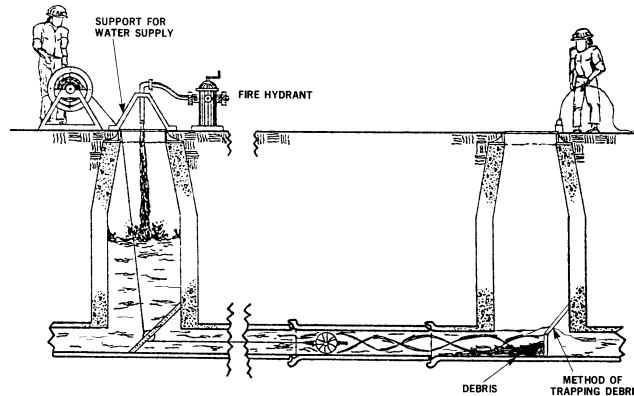

**Sewer Ball Operation**

It takes a lot of water to get this process to work and it doesn't work when there is a lot of debris to move. The scooter is the most advanced tool of the group. It resembles a skateboard with a shield at one end. When debris accumulates in front of the scooter, it is pulled back four or five feet and the shield is dropped to allow a surge of water to push the debris on down the line. Sewer balls and scooters have not been used since the 1950s.

## JET CLEANERS

Hydraulic jet cleaning equipment uses a spray nozzle attached to a hose to scour debris from pipe walls and move it to a manhole where it can be removed. The unit will carry between 500-700 feet of hose on a power reel. A reciprocating positive displacement pump will supply the jet nozzle with between 60-100 gpm at 1800-2220 psi. Jet cleaning and stoppage removal operations should always run upstream to avoid the possibilities of flooding customers' floor drains and basements. The jet nozzle should always stay in motion to prevent accidentally jetting a customer's service line and causing flooding.

The jet nozzle is run upstream at a lower pressure, about 700 psi, until it reaches the next manhole. The upstream manhole should be removed so that a crewmember can signal the operator when the nozzle reaches the manhole. The manhole is left open during the cleaning process for ventilation. Never try to run a jet cleaner past an upstream manhole. The nozzle may come out of the line and coil in the manhole. The actual cleaning is done as the nozzle is retrieved. The pressure is increased to more than 2000 psi during retrieval and the jets scour the pipe and push the debris back to the manhole.

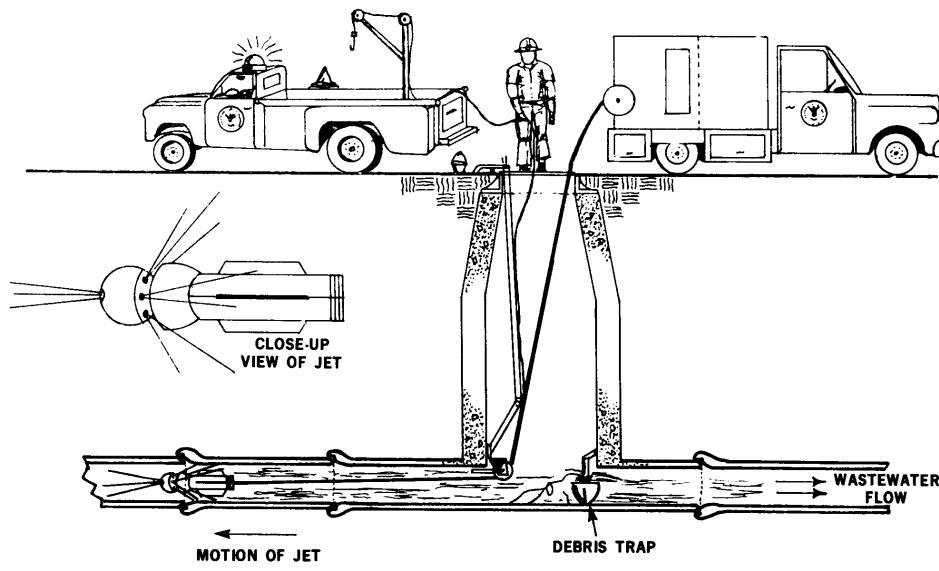

**Jet Cleaner Operation**

Most jet cleaners have a vacuum system to suck up the debris as it is washed back to the manhole. The debris and water are collected in a large tank. The water can be decanted back into the collection system and the grit is hauled to a landfill. Units that don't have vacuuming capabilities are used primarily to string CCTV cables and clear emergency stoppages.

There are different nozzles for different applications and pipe sizes. Nozzles with forward jets are used to clear stoppages. Stoppage clearing nozzles have a set of 15 to 20 degree jets in the back to maximize thrust. Early grease removal nozzles had wider jet angles of 45 to 50 degrees to put more energy on the pipe wall. Spinning nozzle heads are now used to remove grease.

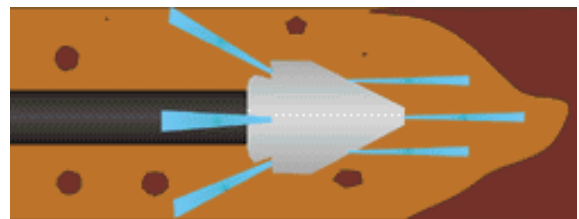

**Forward Jets for Stoppages (Top)  
Rotating Jets for Grease (Left)  
Chain-Style Root Cutter (Below)**

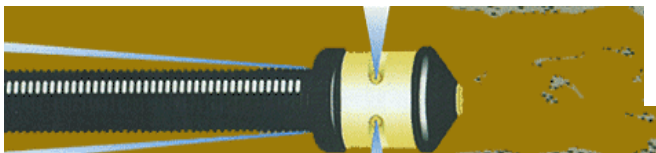

Rotating root saws with either chain whips or rigid blades are used to cut roots. The chain style cutters are easier on PVC piping.

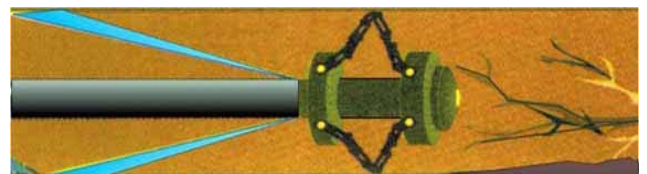

All of these nozzles tend to fly in the center of the pipe. In larger sewer lines grit is removed using a large heavy nozzle that sits on the bottom of the line. Grit nozzles will have forward jets to break up grit deposits and large rear jets that point down at the pipe invert to move the heavy grit deposits. They may weigh 70-80 pounds.



**Grit Removal Nozzles**

These combination jet and vacuum trucks usually carry between 500-1200 gallons of water with them in the saddle tanks. They must be refilled at fire hydrants after each cleaning run. The fill point must be equipped with an air gap to prevent the possibility of a cross connection. Fire hydrants must be opened slowly to prevent water hammer. Dry barrel hydrants must be fully open to prevent jetting water through the drain hole and undercutting the pavement. If the flow is throttled it must be done through a valve attached to the hydrant nozzle while the hydrant valve remains fully open.



**Combination Jet Cleaner  
and Vacuum Truck**

## RODDING MACHINES

Rodding machines are used to cut roots and clear stoppages in lines. They use a long steel rod with a tool attached to the end to drill through the obstacle in the pipe. They use a variety of tools to accomplish different tasks. Few rodding machines are still in service. A jet truck can do all of the things a rodding machine can do and do it faster.

Like a jet cleaner, rodding machine operators should attack roots and stoppages from the downstream manhole. This way roots and debris are carried away from the stoppage as the tool advances. It is important to know how far the tool is into line in case it gets stuck and has requires excavation. Rodding machines generate tremendous torque as they spin the rodding tools. This energy can be dangerous to anyone in the vicinity if the tool gets hung up or the rod breaks. This energy can also result in damage to piping and joints that are offset when this happens.

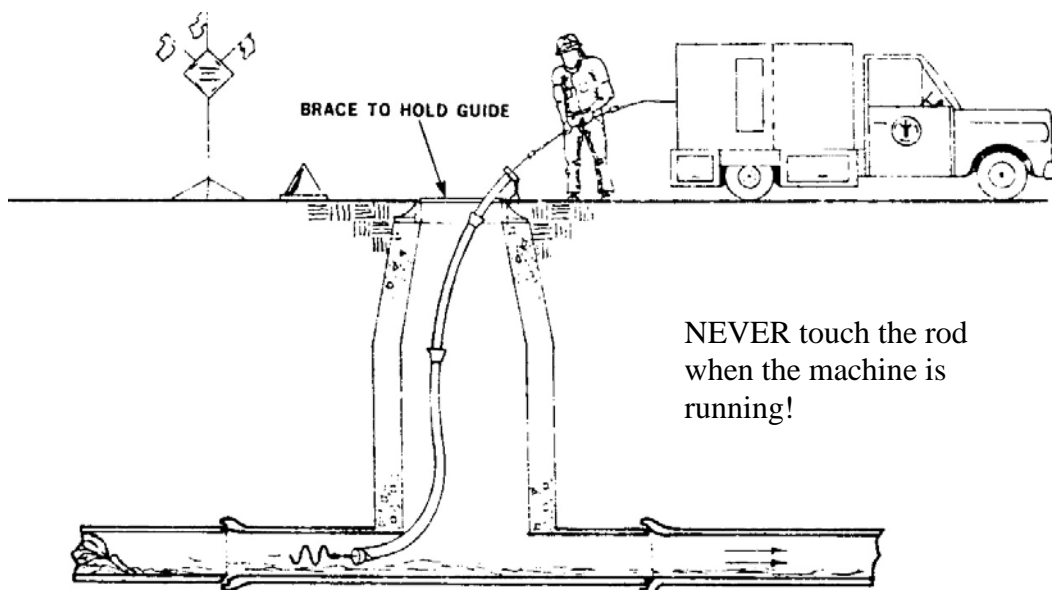

### Rodding Machine Operation

There are two types of root saws used on rodding machines. The spring blade root cutter can damage PVC piping and rods can break if they catch a misaligned joint or a protruding service tap. A circular root saw should be used on plastic pipe.

Corkscrews and augers are used to attack stoppages. The round stock corkscrew is the universal stoppage tool. It should be used if the cause of the stoppage is not known. A square bar auger is used for grit stoppages. A porcupine is used to remove grease.

ROUND STOCK CORKSCREW



AUGER



SPRING BLADE ROOT CUTTER CHUCK

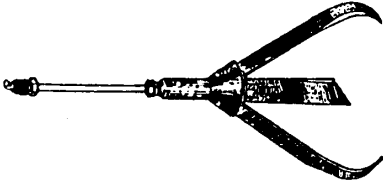

ROOT SAW

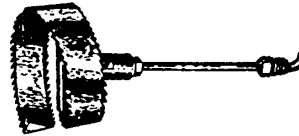

### Rodding Machine Tools

#### BUCKET MACHINES

Bucket machines use two winches to drag a clamshell bucket or porcupine through a line to clean it. They are slow and can damage piping if they get hung up in the line on things like protruding services. Because of the energy and torque involved in the winch operation, mechanical failures can cause serious injury to the operator. The bucket should be removed and an overnight barrel attached to the cables when a job is not completed by the end of the day. Bucket machines are rarely used today because a jet truck will do the same job ten times faster and safer.

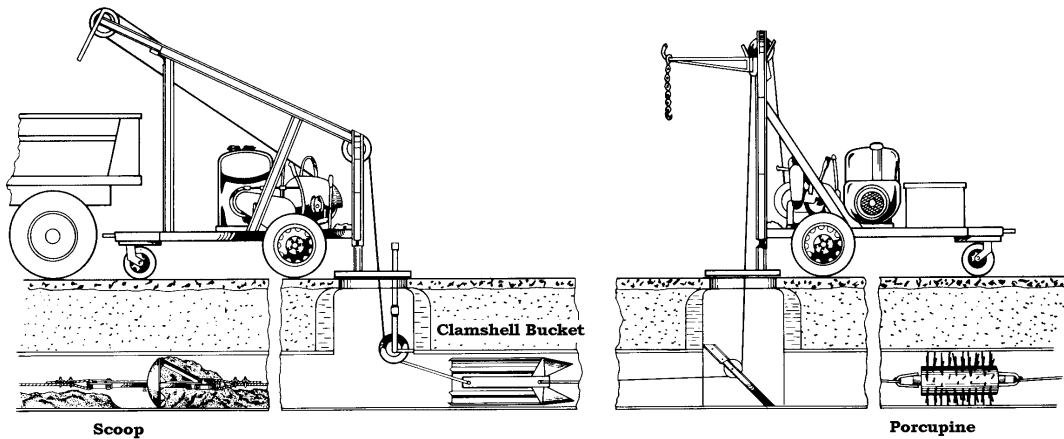

### Bucket Machines

## LIFT STATIONS

There is a limit to how deep you can dig with a backhoe. That limit is between thirty and thirty three feet. When a gravity sewer reaches that depth a lift station is installed to lift the wastewater back up to a point where it begins gravity flow again. They are also used to lift the waste flow over a hill or other terrain obstacle. Lift stations are built as either wet well or dry well installations.

A wet well lift station consists of a wet well to contain the incoming flow and submersible pumps. It is cheaper to build than a dry well lift station, but maintenance can be problematic because of the grease and sewer gases that are present. The wet well is a confined space that requires special entry procedures. It can contain toxic gases even if the top is open.

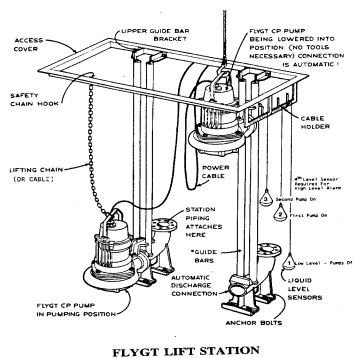

FLYGT LIFT STATION  
Wet Well Lift Station

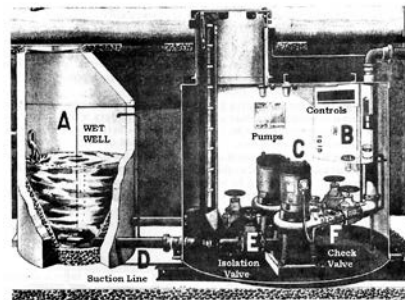

Dry Well Lift Station

A dry well lift station has a wet well to collect the flow and a dry well for the pumps and controls. They are more expensive to build but the machinery is easier to access. The dry well is still a confined space and should not be entered without following the proper confined space entry procedures. Continuous forced ventilation is required during entry.

The discharge line from the lift station is called a force main. It remains a force main until it discharges to a gravity sewer. A check valve on the discharge side of each pump prevents the flow from moving back through the pumps when they are not running. When one of the check valves becomes fouled, the other pumps will pump longer on each cycle because the flow leaks back through the clogged check valve and recirculates back to the wet well. If the pumps alternate and one pump has three to four times the running hours, the pump with the shorter run time probably has a clogged check valve that is allowing recirculation to occur. When seal water is required on a centrifugal wastewater pump an air gap must be used to provide a physical separation for cross connection prevention.

Odor problems can occur in lift stations with long wet well detention times. Air diffusers can be installed to add oxygen and create aerobic conditions. Chlorine, potassium permanganate, and hydrogen peroxide can also be used for odor control at lift stations. Pump start levels can also be lowered so that the pumps cycle more often. Cycling pumps too often can result in motor and starter problems. They shouldn't cycle more than three or four times an hour.

Another pump operational problem occurs when pumps are rotated in and out of service. One of the pumps in the lift station is usually taken off-line every week. When a pump that is full of sewage sits for a week, sewer gases are released that can air lock the pump. If these gases are not purged from the pump before it is returned to service, it may overheat and burn up. This is not an issue with submersible pumps. They have a volute designed to prevent air locking.

It is important to know the net positive suction head (NPSH) for the pumps. It is the minimum suction pressure needed to avoid cavitation. The stop switch for the pump must be set high enough to maintain the pump's NPSH requirement. Lift station pumps may require clean seal water for packing or mechanical seals. If the source of water is the public water supply, cross connection prevention measures must be taken. A physical separation must be maintained using an air gap

Level controls are needed to start and stop the lift station pumps. Some stations use floats as level controls. Unless they are tied off on a "Christmas tree", they can become entangled and cause wet wells to overflow or pumps to burn up. The best means of level control is the use of a pneumatic controller or air bubbler system. Air pressure in the bubbler is equal to the height of water above the end of the tube. The change in pressure as the level changes is used to control the pumps. Pneumatic systems are now being replaced with ultrasonic level sensors in many plants.

## LIFT STATION PUMPS

There are four types of pumps used in lift stations. Most lift stations use end suction centrifugal pumps. Very small lift stations may use ejector-style positive displacement pumps or airlift pumps. Lift stations at treatment plants, lifting water from the primary clarifiers into the activated sludge basins, may use screw pumps.

An ejector pump operates like an air-powered diaphragm pump. Water enters the receiver tank on the suction stroke as air pressure is released. The discharge occurs when a blast of pressurized air is released into the receiver. This literally blows the water out of the tank and up the force main.

Airlift pumps move water by blowing air into the bottom of a standpipe. The rising air bubbles carry water up through the pipe to discharge. An airlift pump is very inefficient and can only lift water five to seven feet.

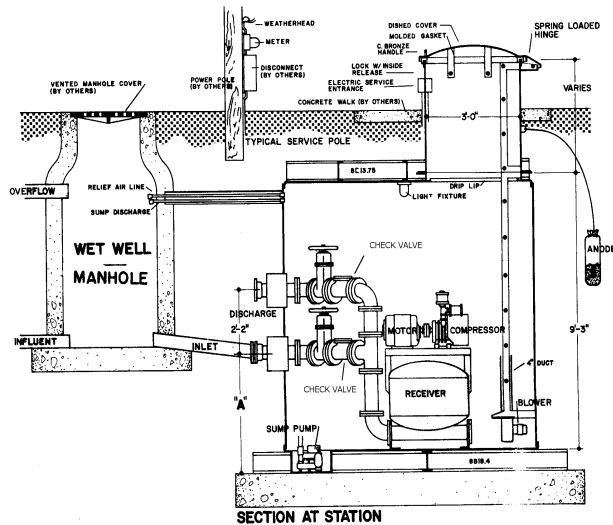

Ejector Pump Lift Station

Screw pumps have been used for centuries in low lift applications. They were used to lift water out of irrigation canals and into farmers' fields. The application for screw pumps in lift stations today is usually to lift water into activated sludge aeration basins. They are constant speed pumps with a variable flow capability.

As the flow increases, the depth of the water at the bottom of the screw increases. The screw will pick up more water with each revolution and the discharge flow increases. The inclined screw is supported by two very large bearings at the top and bottom. These bearings require special attention to lubrication schedules due to the load they carry. Improper installation and misalignment are the most common causes of lower bearing failure.

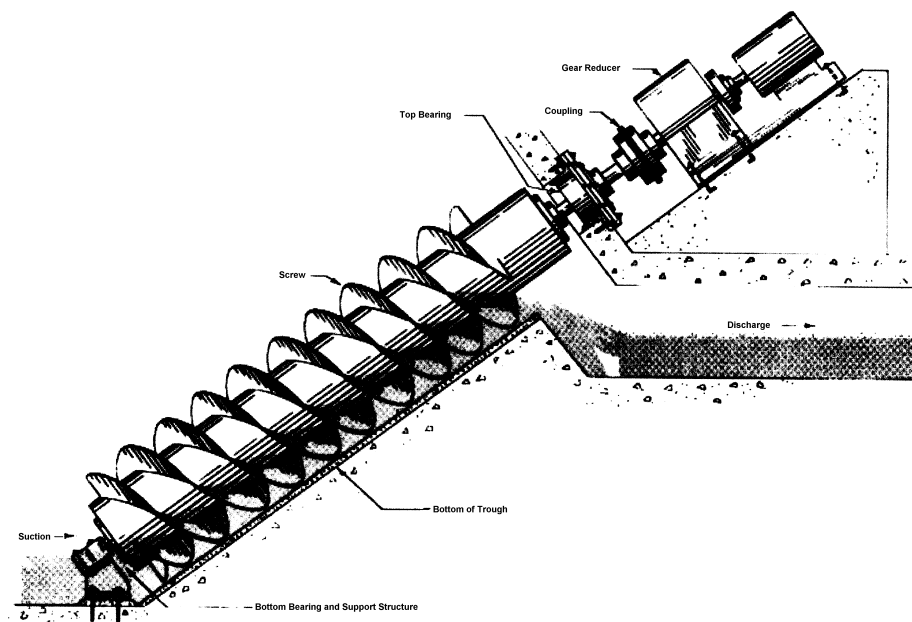

### Screw Pump Installation

## PIPING REPAIR AND REHABILITATION

While many systems contract the installation of new sewer lines to construction companies, system operators are responsible for emergency repairs. Root intrusion can cause infiltration and pipe damage as the root system grows. Improper bedding and trench loading problems can result in misalignment and structural failures. Corrosion from hydrogen sulfide gas will degrade the crown of the pipe wall until a catastrophic failure occurs. Sometimes the piping has simply reached its normal useful life and fails from old age.

When a line break occurs, the first priority is to establish a bypass pumping operation to divert wastewater flow around the break to a downstream manhole. A pneumatic plug is inserted in the line at the manhole upstream of the break. Whenever possible the plug should be inserted in the upstream side of the manhole. The pump is set up at the next upstream manhole and hose run to the manhole below the break.

This may not be practical if it results in a run of over 600 feet or if the hose has to cross a busy street where traffic can't be diverted. If the plug is inserted in the downstream side of the manhole care must be taken to properly secure it. If it deflates it can get pushed into the line and cause another stoppage. A plug inserted in the upstream side will pop out into the manhole when it deflates and is less likely to get drawn downstream. In either case a pneumatic plug should always be tethered and secured.

System operators must be properly trained and equipped for line repair work because these repair jobs can be some of the most hazardous excavations that are encountered in collection systems. Once soil becomes saturated it is classified as Class C soil and requires 1½ to 1 sloping or solid sheeting for shoring. Trench boxes are also used when saturated soils become too unstable for the safe installation of shoring. An engineer must design shoring for excavations more than 14 feet deep.

### PIPE REPAIRS

Misaligned or broken pipe must be removed and new pipe spliced in its place. The straight pipe ends are connected using one of several types of rubber slip couplings. These couplings can be simply rubber sleeves with radiator-style clamping bands to seal the ends. Heavier clay pipe may require an outside steel sleeve for proper support.



---

RUBBER SLIP COUPLINGS

---

Great care must be taken to ensure that the repaired section of pipe is properly bedded and backfilled for support. If the bedding material is not properly tamped around the repair, the trench loading can cause another failure to occur. Service lines are reconnected to the pipe using a saddle tap and slip coupling.



---



---

STEEL SLEEVE SLIP COUPLINGS

---



---

## CHEMICAL GROUTING

Leaking pipe joints can draw bedding material and soil from outside the pipe into the line. This heavy material can easily create stoppages far downstream of the actual leak. The loss of the support material around pipe can result in misalignment of joints or a complete collapse of the line. Leaking pipe joints and joints with root intrusion may be repaired without replacement by sealing the joint with a chemical grout. The grouting process can only be used if the pipe wall integrity has not been compromised.

The chemical grout is not cement that hardens and gives support. It is a low viscosity polymer-based liquid that can be pumped into the joint and out into the surrounding soil. As the grouting cures it congeals into a gel that binds the material outside the joint to form a watertight seal. Root inhibiting chemicals can also be mixed with the grout to prevent additional root intrusion.

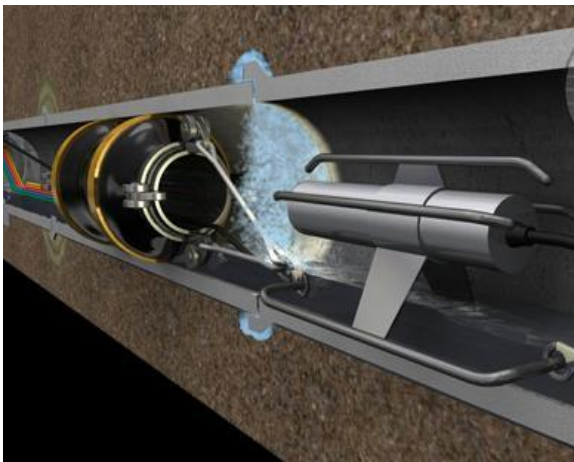

---



---

POSITIONING THE PACKER UNIT

---



---

A line that is going to be grouted must first be cleaned with a jet truck. Roots must also be cut prior to the packing operation. A power winch is set up at the remote manhole. A jet truck or rodding machine is used to run a cable back to the manhole where the grouting unit is located.

A CCTV camera is attached to the cable facing backwards. The grouting packer is attached to the camera. Five hoses are attached to the packer unit. Two carry grouting chemicals and the others are air lines used to inflate the three packer compartments and pressure test the seal.

The camera is used to center the packer unit under the joint. Once the packer is positioned the end chambers are inflated to seal the center of the unit where the grout will be injected.

After the center area is properly sealed, grouting chemicals are pumped into the void area in the center. The center of the packer unit is inflated to force the grouting chemicals into the joint and the surrounding soil.

It takes forty to sixty seconds for the grout to expand and solidify. After it has set up, the center of the packer is deflated and the seal is pressure tested. Some packing units are also capable of sealing sewer taps and lateral connections.

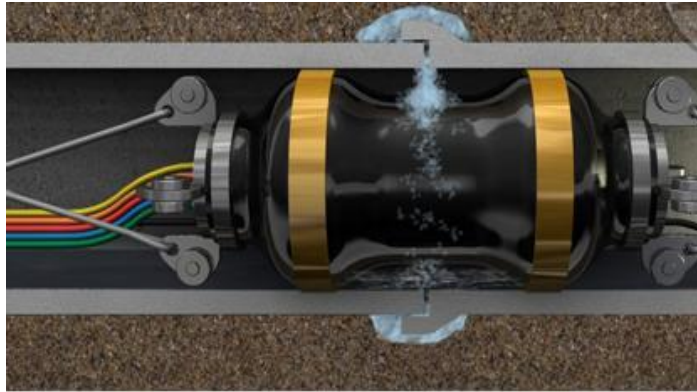

INFLATING THE ENDS OF THE PACKER UNIT

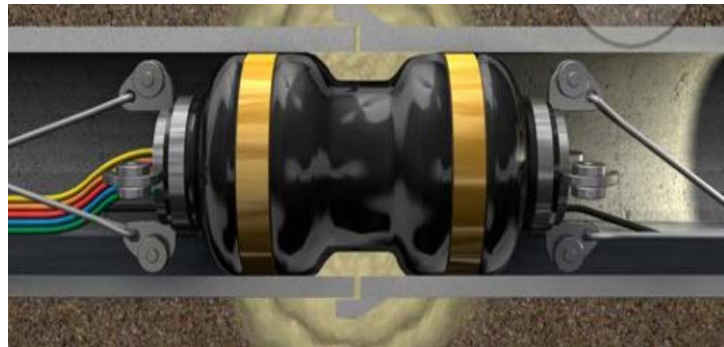

GROUT IS INJECTED AND THE CENTER IS PRESSURIZED

## LINE REHABILITATION

Many collections systems are faced with the problems caused by deterioration in piping that can result in excessive infiltration, stoppages, and eventually catastrophic structural failure. Problems can also be created when flows begin to reach the carrying capacity of the line due to urban development in the area. Replacing a sewer line is a very expensive and disruptive operation. There are several options available to collection systems that can rehabilitate an undersized or failing sewer line. These processes are more cost effective and much less invasive than retrenching and replacing the pipe. All of these processes involve the insertion of new flexible piping or a liner into the existing pipe to seal it.

### SLIP LINING

Slip lining has been used to rehabilitate aging sewer lines for over fifty years. The process involves pulling or pushing a flexible plastic pipe through an existing line. High Density Polyethylene (HDPE) pipe, PVC pipe, and Vylon pipe are most commonly used for slip lining operations.

Another advantage of slip lining is that it requires a minimal amount of equipment and can be done by most collection systems contractors. The biggest disadvantage is that the liner pipe is one to two inches smaller in diameter than the original pipe. Proponents argue that the reduced friction in the plastic liners makes up for the loss of cross-sectional area.

The line must be hydraulically cleaned prior to slip lining. It should also be CCTV inspected to make sure it is suitable for slip lining. Misaligned joints, protruding taps, or severe changes in grade may make it impossible to slip line.

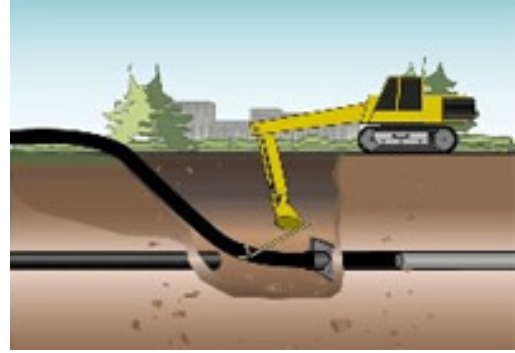

---

SLIP LINING - BACKHOE PUSHES HDPE PIPE

---

HDPE pipe segments are heat-welded together by a process known as butt fusion to form a continuous pipe that can be hundreds of feet long. The pipe is pulled through the line with a winch or pushed with a backhoe. The PVC and Vylon pipe segments are connected with compression fittings and are pushed into the pipe using a backhoe. The only excavation is a small sloped trench that used to guide the flexible pipe into the old line. When HDPE is used the wastewater flow must be bypassed around the slip lining operation until the liner pipe has been completely inserted. Segmented PVC or Vylon pipe can be pushed into the pipe without the need for a bypassing operation.

After the liner has been pulled through the pipe, it must sit for twenty four hours before it is grouted at each end and services are reattached to the new liner. The waiting period is necessary because the pipe has stretched from the force required to drag it through the line. It must be allowed to shrink back to its original length first or the taps may pull loose.

## **PIPE BURSTING**

Pipe bursting is another method of slip lining. It involves breaking up the existing pipe so that a liner that is as large, or larger, than the existing pipe can be pulled through the expanded space. It is becoming much more popular than standard slip lining because of this ability to upsize the existing piping. It can also be used where misalignment or grade problems might make normal slip lining impossible.

An insertion pit is dug to allow placement of the bursting head and liner pipe in the existing line. A cable is attached to the bursting head and a winch draws it through the pipe. The nose of the bursting head is smaller than the existing pipe to maintain alignment and to ensure a uniform burst. The base of the bursting head is larger than the existing pipe and the liner, if it is larger than the pipe. The cable maintains a constant lateral pressure to keep the bursting head moving forward as the existing pipe wall is crushed. The liner is pulled into the pipe as the bursting head moves forward.

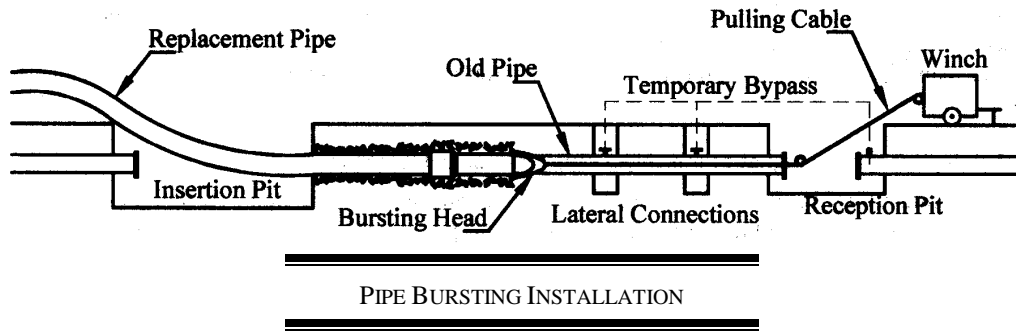

There are three different types of pipe bursting systems. The most popular method of pipe bursting is pneumatic bursting. Pneumatic bursting systems use a pneumatic boring tool to drive the bursting head through the pipe. Pulsating air pressure acts like a battering ram to move the bursting head forward. Hydraulic expansion systems use a hydraulically operated bursting head that expands and closes sequentially crushing the pipe as it advances. This method requires more winch capacity since it takes more effort to pull the head through the pipe.

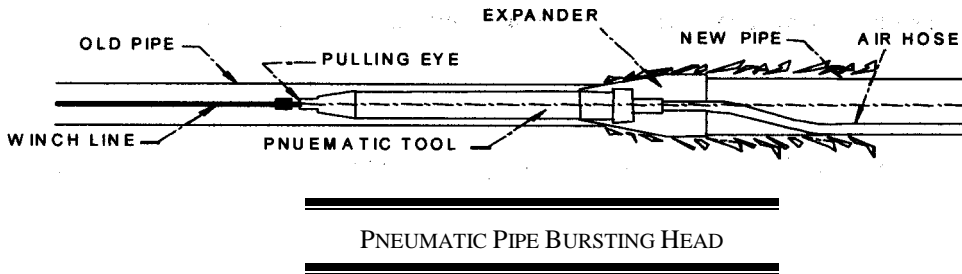

The third type of pipe bursting is the static pull method. Instead of using pneumatics or hydraulics to break up the pipe, it relies on the brute force of the pull winch to draw it through the pipe. It takes a tremendous amount of force to burst pipe using this technique. Even small pipes may require winches rated at fifty tons or more.

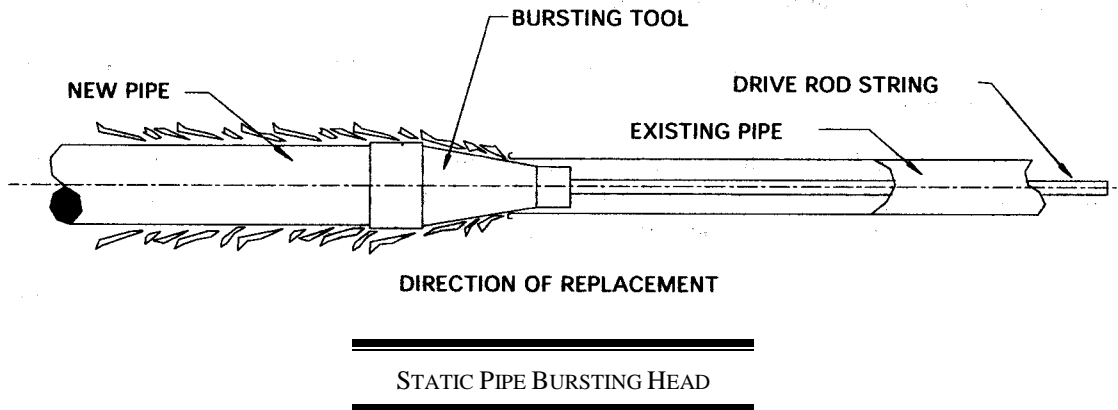

## CURED-IN-PLACE PIPELINING (CIPP)

Sewer lines that are still structurally sound can be lined and sealed with a flexible liner that is inserted in the pipe and then held in place until resins in the fabric harden. This process is known as cured-in-place pipelining or in-situ pipelining. First the pipe must be cleaned and inspected to determine if it is structurally suitable for the process. The resins in the liner will harden and but doesn't provide structural support. A badly deteriorated pipe should slip lined.

The liner is a large tube of synthetic fabric webbing the same diameter as the pipe. An inflatable bladder is placed inside the fabric tube and the liner is saturated with a waterproof epoxy resin. The liner is folded flat and pulled through the pipe by a remote downstream wench. The bladder is inflated to push the liner out against the pipe wall. The liner is held in place for thirty to sixty minutes until the epoxy resin hardens and bonds the liner to the inside of the pipe. Hot water is circulated through the bladder in some systems. The heat can dramatically decrease the curing time for the resin.

This method of rehabilitation is used in very large diameter concrete lines and oddly shaped brick sewers. It can seal them and protect them from crown corrosion caused by acid formation.

An in-situ lining process only requires an excavation the size of a manhole, instead of the long pull trenches needed for slip lining. The biggest disadvantage is the special equipment and expertise required to install the lining correctly means that only a few large contracting firms will be able to do these jobs. The installation costs are therefore normally higher than with slip lining.



## BASIC STUDY QUESTIONS

1. What are some of the components of a wastewater collection system?
2. What is the minimum velocity requirement for gravity sewers?
3. What are the two types of lift stations?
4. What is the main disadvantage of concrete sewer piping?
5. Where are manholes located?
6. Where are inverted siphons used?
7. What are the three most common types of lift station pump?

### **BASIC SAMPLE TEST QUESTIONS**

1. Vitrified clay pipe is usually joined using:
  - A. Mechanical joints
  - B. Bell and Spigot joints
  - C. Threaded fittings
  - D. Glue
2. Sewer gases in collection systems:
  - A. Represent a health hazard
  - B. Can corrode concrete pipe
  - C. Create odor complaints
  - D. All of the above
3. The problem with sewer balls and scooters is:
  - A. Flooding of upstream residences
  - B. Odor complaints
  - C. Equipment costs
  - D. All of the above
4. The discharge line from a lift station is called a:
  - A. Flow vent
  - B. Return line
  - C. Force main
  - D. Station overflow
5. A service line should slope at least:
  - A. 1/8" per foot
  - B. 1/4" per foot
  - C. 1/2" per foot
  - D. 1" per foot
6. The crown of a pipe is:
  - A. Outside top of the pipe
  - B. Inside top of the pipe
  - C. Inside bottom of the pipe
  - D. Left side of the pipe

4. Illegal taps can be found by doing:

- A. A smoke test
- B. A pressure test
- C. A flow test

### **ADVANCED STUDY QUESTIONS**

1. When is a drop manhole installed?
2. What should be done to control roots in the system?
3. What happens when a lift station pump check valve gets clogged?
4. What are the disadvantages of using a rodding machine?
5. How do you calculate the slope of a pipe?
6. What is the procedure for cleaning a line with a jet cleaner?
7. At what depth is an engineer required to design shoring for an excavation?
8. What are the three types of pipe bursting processes?
9. What types of pipe are used for slip lining?
10. What are the disadvantages of CIPP pipe lining?

## ADVANCED SAMPLE TEST QUESTIONS

1. When connecting a water line to a wastewater pump always install:
  - A. A vacuum breaker
  - B. An air gap
  - C. A double check valve
  - D. All of the above
2. Class "A" bedding material is:
  - A. Sand
  - B. Gravel
  - C. Concrete
  - D. Rocks
3. The best way to determine the condition of a sewer line is:
  - A. A smoke test
  - B. A closed circuit TV inspection
  - C. A flow test
  - D. A pressure test
4. The only place smoke should be seen during a smoke test is:
  - A. The floor drains
  - B. In the yard
  - C. Roof gutters
  - D. Roof vents
5. Which type of pipe is likely to have crown corrosion due to hydrogen sulfide gas?
  - A. PVC
  - B. VCP
  - C. Concrete pipe
  - D. All of the above
6. Which sewer line rehabilitation process requires the smallest excavation?
  - A. CIPP process
  - B. Pipe bursting
  - C. Slip lining
7. Which slip lining process requires the most wench capacity?
  - A. Static pull bursting
  - B. Pneumatic bursting
  - C. Hydraulic bursting



## PUMPS

Pumps provide the means for moving water through the system at usable working pressures. The operation and maintenance of these pumps are some of the most important duties for many water utility operators. There are two basic types of pumps used in water and wastewater systems. The most common type of pump is the centrifugal pump. The other type is the positive displacement pump.

All pumps are rated by the flow they produce and the pressure they must work against. Centrifugal pumps are used for high flow and low head pressure applications. Lift station pumps or primary service pumps are required to move high volumes of water but normally lift water less than fifty feet. Centrifugal pumps are ideally suited to these types of applications and are much more efficient than positive displacement pumps of comparable size.

Positive displacement pumps are used for low flow and high pressure applications. High pressure water jet systems like those used for sewer line cleaning use positive displacement pumps. They generate pressures in excess of 2000 psi and the flows seldom exceed 100 gpm. Sludge pumps and chemical feed pumps are also likely to be positive displacement pumps. Piston pumps, diaphragm pumps, and progressive cavity screw pumps are the most common types of positive displacement pumps.

Another difference in centrifugal and positive displacement pumps has to do with how they react to changes in discharge pressure. If the pressure a centrifugal pump works against changes the flow from the pump changes. As the pressure increases the flow from the pump will decrease and when the pressure drops the flow will increase. Positive displacement pumps do not react to changes in pressure. The flow does not change when the discharge pressure changes. This is the main reason that positive displacement pumps are used for chemical feeding and sludge pumping. The operator knows that every time the pump stroke, it is pumping the same amount of fluid. This is important if accurate records are to be kept of chemical dosages and pounds of solids that are moving through the system. The most common positive displacement pump is the reciprocating pump.

<b>TYPE OF PUMP</b>	<b>PRESSURE/FLOW RATING</b>	<b>CHARACTERISTICS</b>
Centrifugal	Low Pressure/High Flow	Flow changes when pressure changes
Positive Displacement	High Pressure/Low Flow	Flow doesn't change when pressure changes

## CENTRIFUGAL PUMPS

A centrifugal pump moves water by centrifugal force. Any time an object moves in a circular motion there is a force exerted against the object in the direction opposite the center of the circle. This would be easier to explain if we use an example consisting of a person with a bucket full of water. If the person swings the bucket in a circle fast enough, the water will stay in the bucket even when it is upside down. The force that holds the water in the bucket is called centrifugal force. If a hole is made in the bottom of the bucket, and it is swung in a circular motion, the centrifugal force will push the water out of the bucket through the hole. The same principle applies when water moves through a centrifugal pump.

An impeller spins inside a centrifugal pump. It is the heart of the pump. Water enters at the center or the eye of the impeller. As the impeller rotates the veins pick up the water and sling it out into the pump body under pressure. It is the pressure exerted by the vanes that moves the water out of the pump. The suction created as the water leaves the impeller draws more water into the impeller through the suction eye.

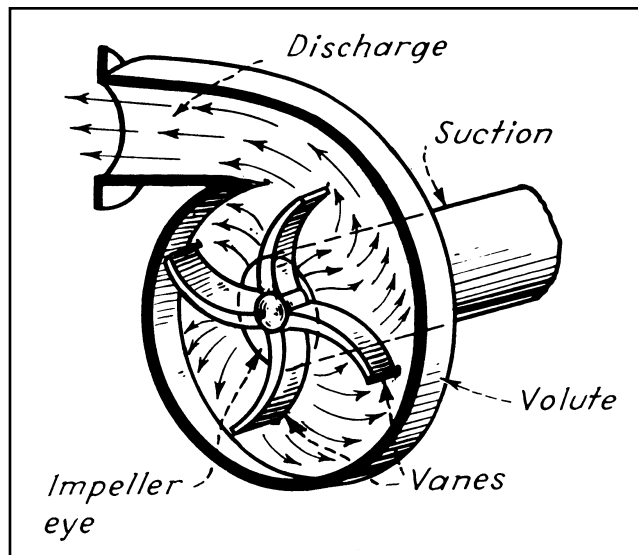

### IMPELLER ROTATION AND CENTRIFUGAL FORCE

The number of vanes and the sweep of the veins determine the performance characteristics of the impeller. As vanes are added the impeller will produce higher discharge pressures and lower flows. The same situation applies to increasing the length or sweep of the vanes. Reducing the number of vanes or the sweep of the vanes will increase the flow and reduce the pressure.

## TYPES OF CENTRIFUGAL PUMPS

There are three basic types of centrifugal pumps. Although they differ in design, all three have the same basic components. The first centrifugal pumps were called horizontal split case pumps. The shaft was horizontal and the casing was split in half. With the top half of the casing removed, the entire rotating assembly can be removed for maintenance. The problem with horizontal pumps is the floor space they require.

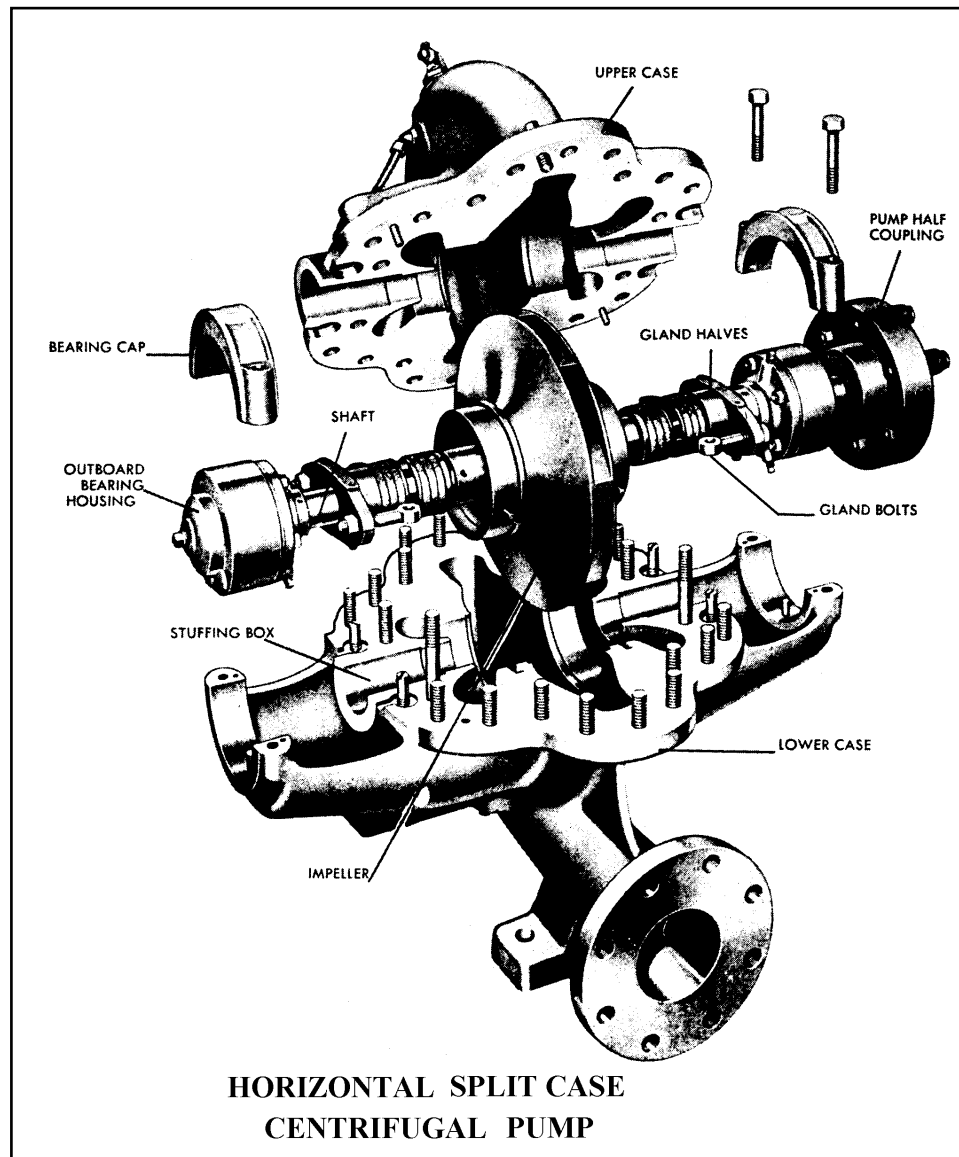

End suction centrifugal pumps were designed to take up less floor space. The suction piping enters at the end of the pump and discharges at a 90° angle to the suction. This allows more flexibility in installation and, since the pump could be mounted vertically, more pumps in a given floor space.

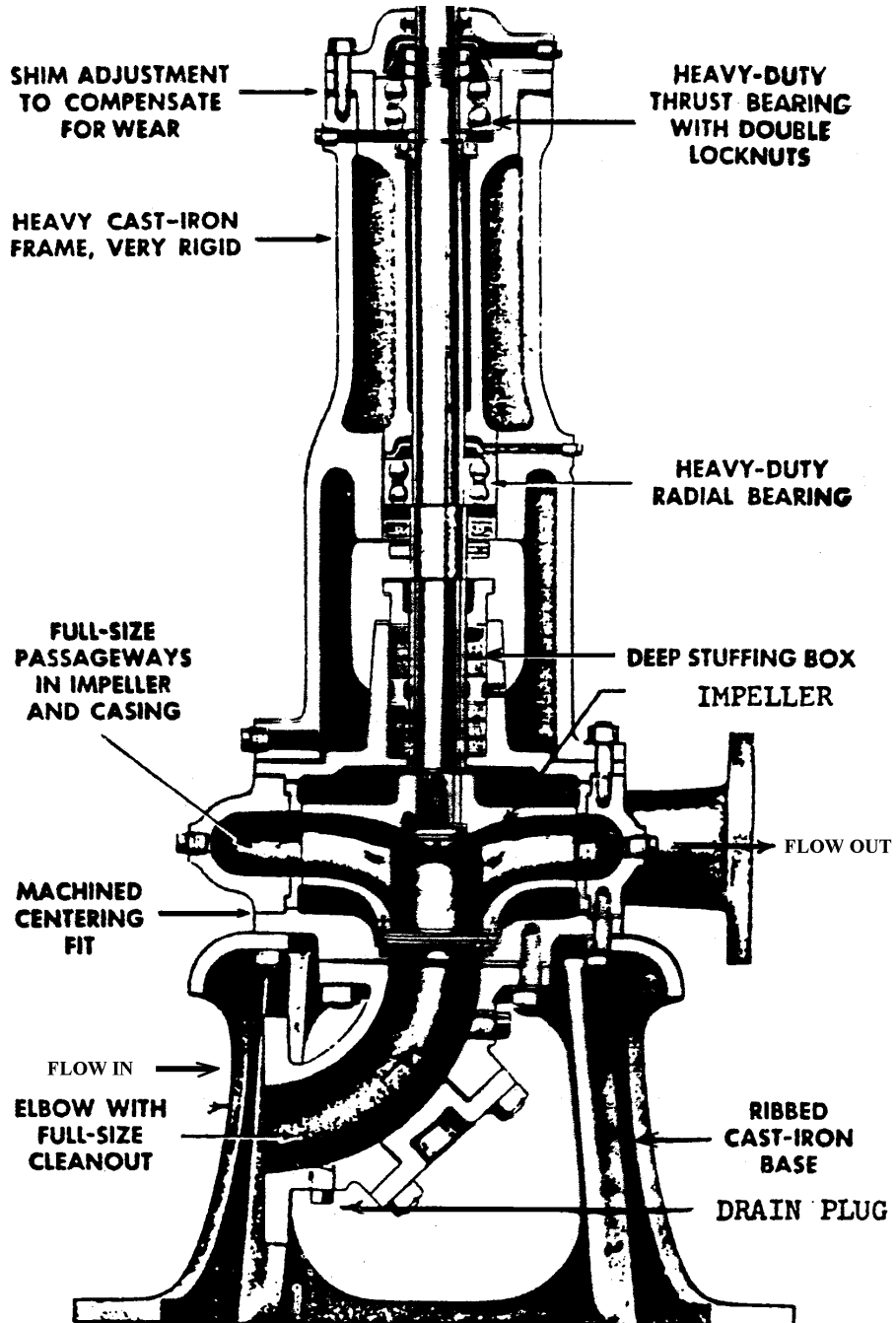

**END-SUCTION CENTRIFUGAL PUMP**

A vertical turbine centrifugal pump consists of multiple impellers that are staged on a common vertical shaft. The impellers are designed to bring water in the bottom and discharge it out the top of the pump. This results in axial flow as water is discharged up through the column pipe. Staging the impellers in these pumps can create very high discharge pressures, since the pressure increases as the water moves through each stage.

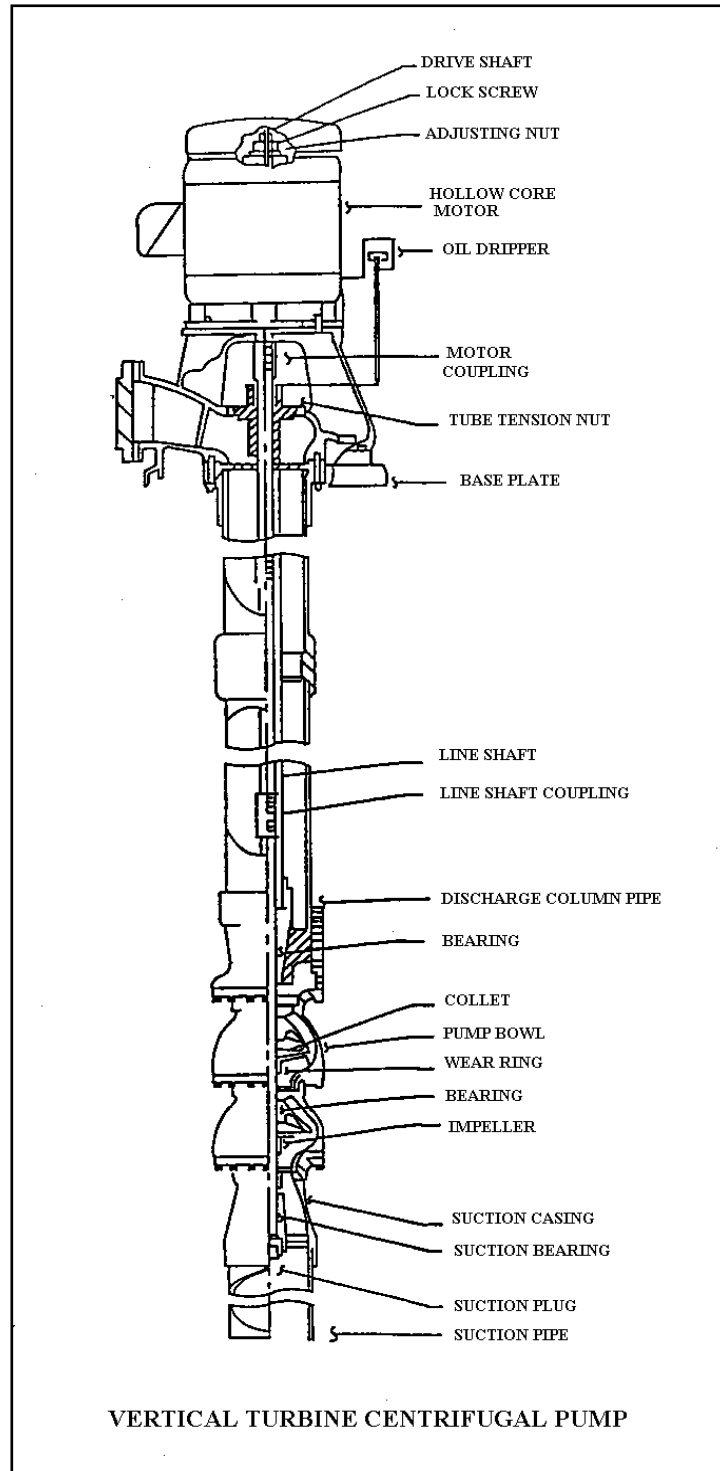

## CENTRIFUGAL PUMP COMPONENTS

Before we can discuss operations and maintenance of a centrifugal pump, it is important to understand how a pump is put together and the role of each of the pump components. A centrifugal pump is constructed from only a handful of major components. Let's take a look at how these pieces fit together to make a pump.

The impeller is attached to the pump shaft. The shaft must be straight and true so that it will not cause vibration when it rotates. The shaft should be protected from potential damage caused by the failure of other pump parts. A shaft sleeve is used to protect the shaft in the area where the shaft passes through the pump casing.

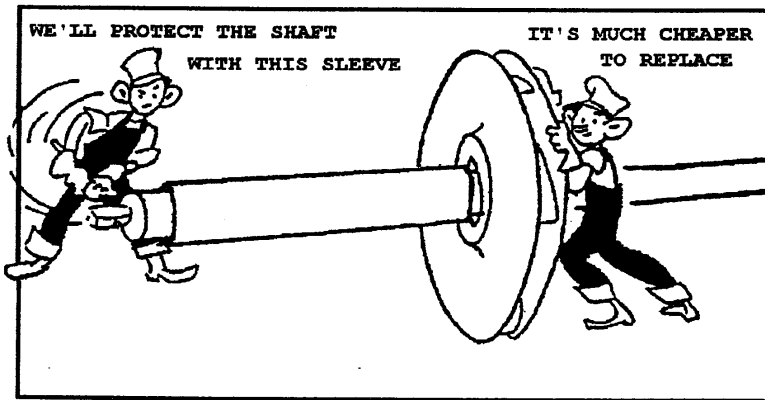

This rotating assembly must be supported as it spins in the pump. Bearings hold the spinning shaft in place. There are two types of anti-friction bearings normally found in centrifugal pumps. One type of bearing is designed to keep the shaft from wobbling from side-to-side as it spins. This side-to-side motion is referred to as radial movement. The bearings used to prevent radial movement of the shaft are called radial bearings. The most common variety of radial bearing is the standard ball-type roller bearing

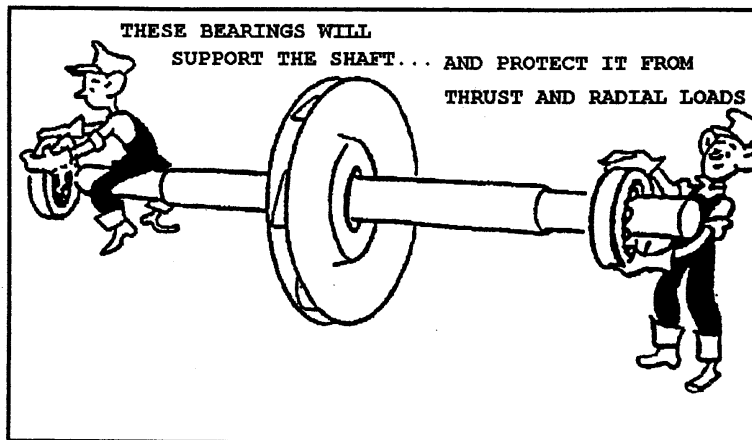

Water entering the suction eye pushes against the top of the impeller exerting force in the same axis as the pump shaft. This is referred to as upthrust. The pressure developed inside the pump also pushes against the impeller in the opposite direction. This downward force is referred to as downthrust. Bearings designed to support the shaft against this type of force are called thrust bearings. The most common variety of thrust bearing is an angular contact ball bearing.

The rotating assembly is placed in a pump casing. Part of the pump casing is specially designed to collect and direct the flow of water as it enters and leaves the impeller. This part of the pump casing is called the volute.

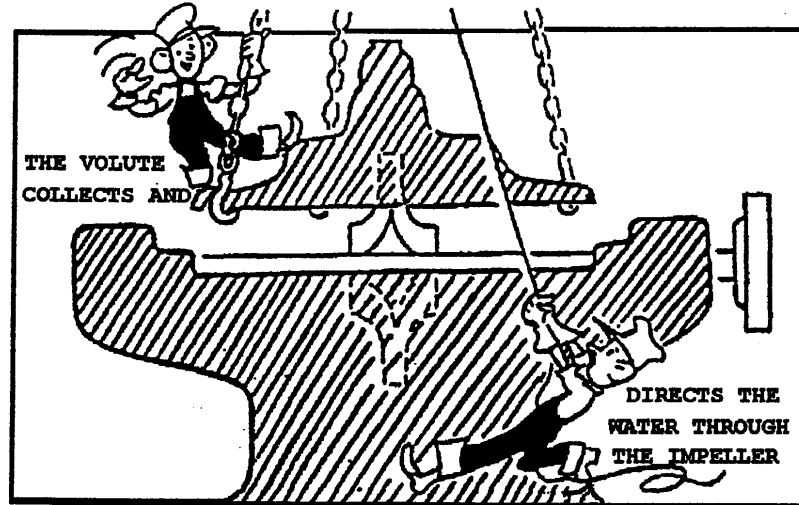

The suction and discharge piping are attached to the pump casing. The suction piping will always be larger than the discharge piping. Suction piping is designed to bring water into the pump at 4 feet per second in order to minimize the friction loss on the suction side of the pump. The discharge piping is designed to carry water away from the pump at seven feet per second.

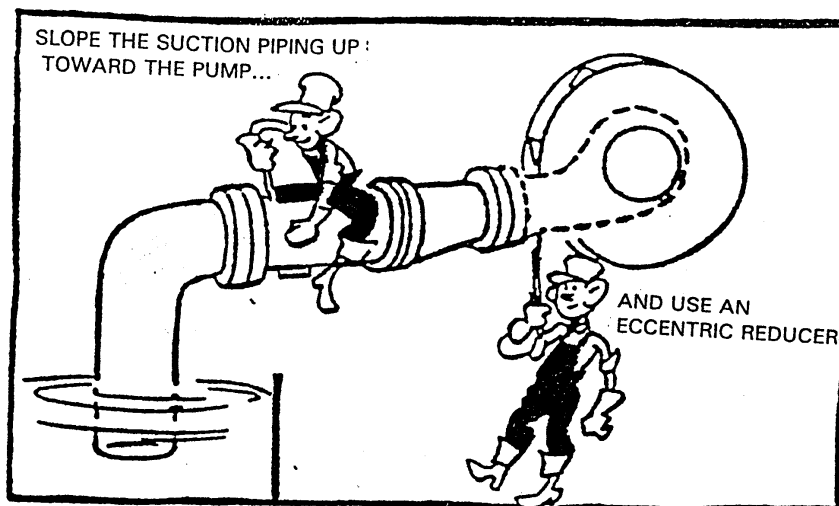

There are several important aspects to suction piping installation. Horizontal runs of piping should slope upward toward the pump. Any reducers on the line should be horizontal across the top instead of tapered. A reducer that is flat on one side is known as an eccentric reducer. A reducer that is tapered on both sides is called a concentric reducer.

These installation practices prevent the formation of air pockets in the suction piping. Air trapped in the suction piping can create restriction of flow into the pump. It is also important to make sure there are no leaks in the suction piping that might allow air to be drawn into the pump. The pump must never support the piping. Placing that kind of stress on the casing can cause it to crack or distort enough to cause damage to the rotating assembly.

Now that the casing is assembled and the piping is in place, we can spin the impeller and begin moving water. Water will enter from the suction side of the volute and will be slung out of the impeller. Unfortunately, the water will try to pass from the high pressure side back to the suction side of the pump and recirculate through the impeller again.

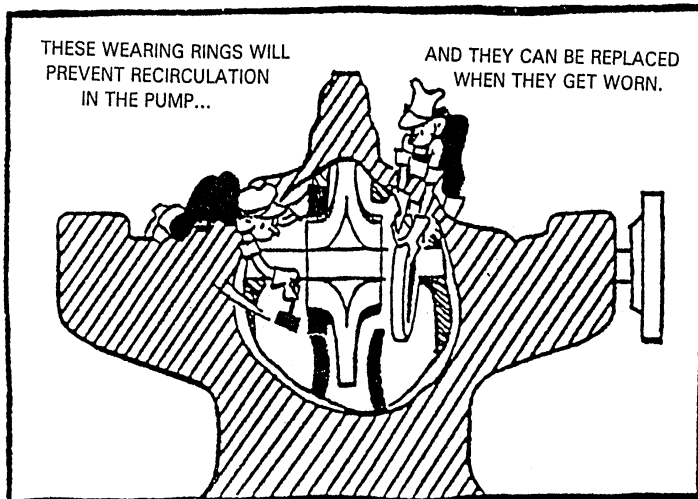
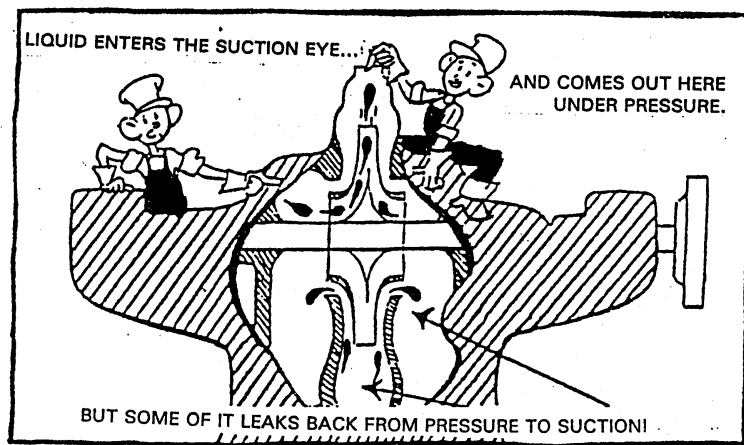

The pump casing could have been machined to close this gap. But the fit would become worn and widened over time. Wearing rings are installed in the pump and the impeller that reduce the clearance between them to as little as 0.010". These rings are removable and can be replaced when they become worn. Always measure the wearing ring diameters whenever the pump is disassembled. If the gap is too large they should be replaced

There is another area of the pump that will require some attention. Something must be done to plug the hole where the shaft enters the pump casing. This is a place where water can leak out and air can leak into the pump. The part of the pump casing that the shaft passes through is called the stuffing box. It's called the stuffing box because we are going to stuff something in the box to keep the water in and the air out.

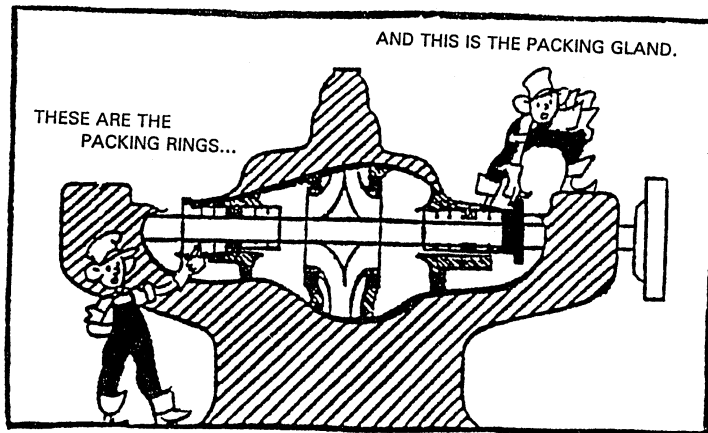

This will usually be rings of pump packing. Several rings of packing are placed in the stuffing box. A metal insert ring fits on top of the stuffing box and is used adjust or tighten the packing down to minimize water leakage. It is called a packing gland.

The packing rings are in contact with the shaft sleeve as it rotates. Friction and heat are generated in the stuffing box when the pump is running. Water is generally used to cool the packing rings during operation. This means that some water must leak out of the stuffing box when the pump is running. Water may simply be allowed to leak through the packing rings from inside the pump to cool them.

This water may be come from the low pressure side of the pump and may not be under enough pressure to leak past the packing rings when the packing gland is properly adjusted. If this is the case, high pressure water from the discharge side of the pump may have to be piped into the stuffing box. Seal water piping is used to supply this water to the packing.

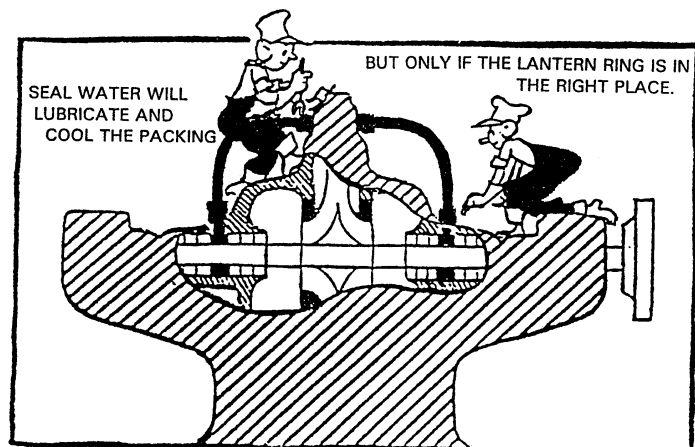

A lantern ring is used to get the water to the inside of the packing rings where the heat is being generated. The lantern ring is a metal ring that has holes in it. Water circulates around the outside of the lantern ring and passes through the holes to get to the inside of the packing rings. The lantern ring must be aligned with the seal water port on the stuffing box to make sure that water will get to the center of the stuffing box. Whenever a potable supply is used for a pump that is pumping wastewater, an air gap must be used to prevent a possible cross-connection.

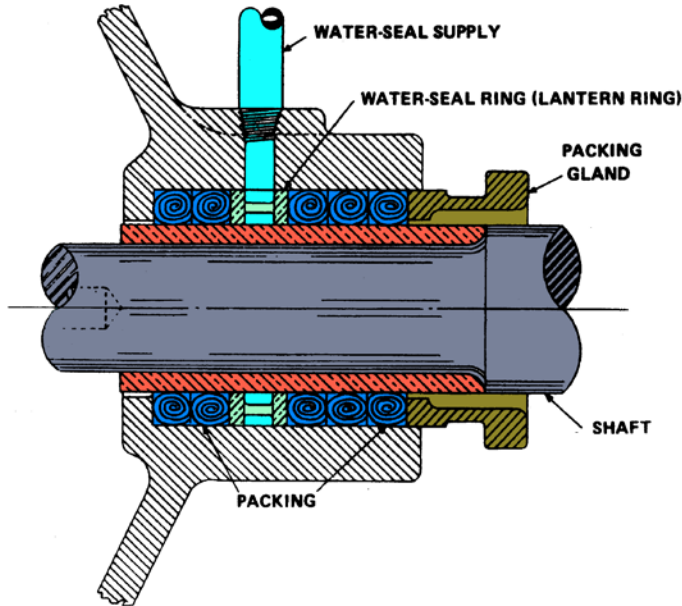

STUFFING BOX WITH LANTERN RING

If there isn't enough seal water moving past the packing and rotating pump shaft to cool them properly, the packing will overheat. If the packing is allowed to overheat, the lubricant in the packing will be driven away from the shaft. The packing will become glazed, much like nylon cord that has been burned at the end. The glazed packing will then start cutting into the shaft sleeve, creating more friction and heat. The result will be packing failure and a severely damaged shaft sleeve.

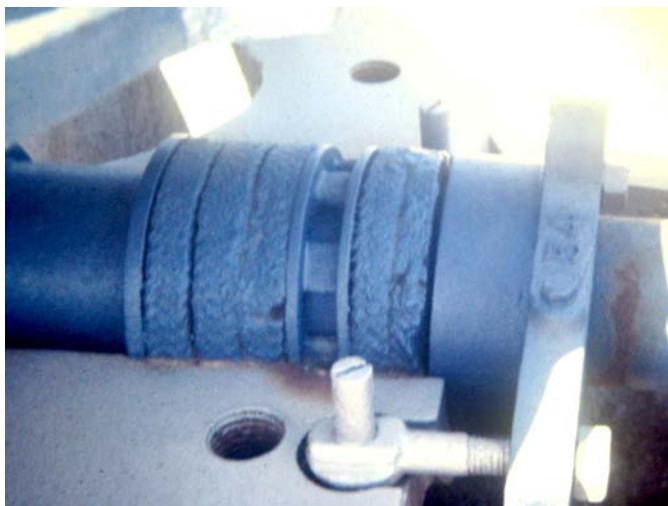

**Stuffing Box on a Horizontal Split Case Pump**

Pumps that do not have packing in the stuffing box will be equipped with a mechanical seal. Mechanical seals are comprised of two highly polished seal faces. One seal face is inserted in a gland ring that replaces the packing gland on the stuffing box. The other seal face is attached to the rotating shaft. It is held in place with a locking collar and is spring loaded so that there is constant pressure pushing the two seal faces together. The seal faces are lapped to mirror finish. The matched faces create a watertight seal without a gasket

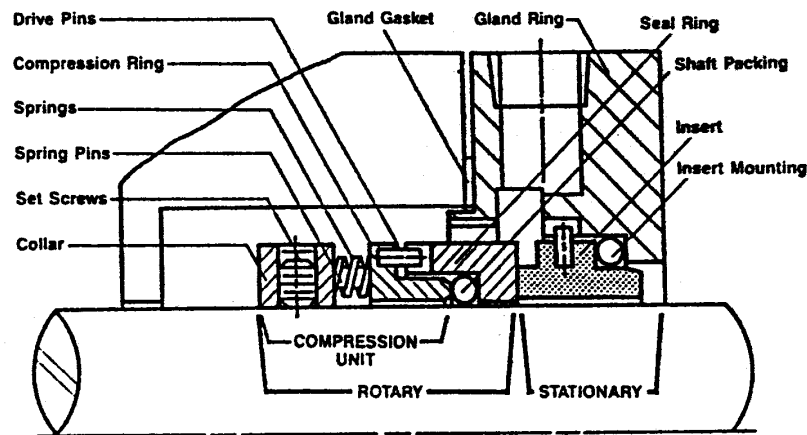

**MECHANICAL SEAL COMPONENTS**

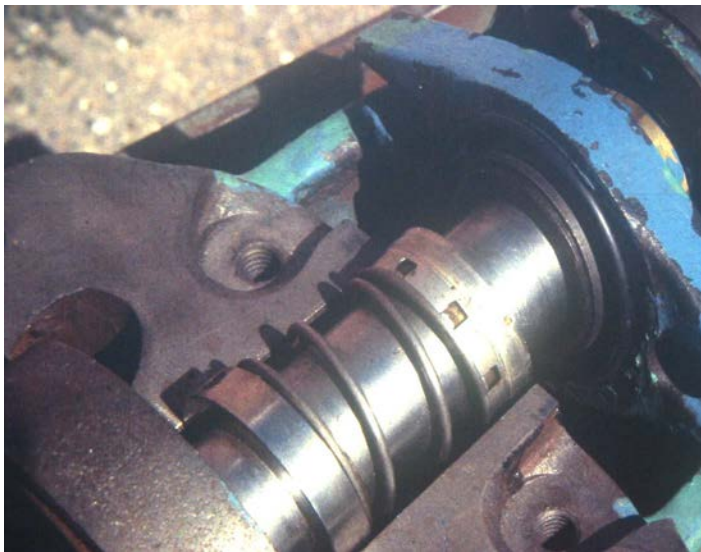

**Mechanical Seal on a Horizontal Split Case Pump**

When the pump runs seal water is piped into the stuffing box under enough pressure to force the seal faces apart. The seal faces don't touch when the pump is running, but the friction loss created as the water pushes them apart and the centrifugal force that is generated prevents any leakage from the seal faces. Failure of the seal water system will result in the seal faces rubbing against each other. The friction that is generated when this happens can destroy a mechanical seal in a matter of seconds.

## **PUMP HYDRAULICS**

When a pump is installed, it is important to make sure that it is designed to pump against the correct head pressure. Pumps that are not properly sized for a specific application will fail to give satisfactory performance. The majority of complaints regarding pump performance usually result from placing a pump in an application that requires it to operate outside its designed flow or pressure ratings.

In order to get the right pump for the job you must know not only how much water must be moved but also how much pressure it is going to pump against. Determining how much water needs to be pumped is the easy part. A pump dealer may have fifteen different pumps that are rated for 500 gpm. Some of them will pump 500 gpm against 500 feet of head and some will only pump 500 gpm at 50 feet of head pressure. The trick is figuring out how much pressure the pump will have to work against.

The following steps should be taken when sizing a pump:

### **1. Determine the gpm:**

The pump should be able to meet the peak daily demand that will be encountered.

### **2. Determine the suction head:**

The suction head is the vertical distance from the surface of the water supply to the centerline of the pump. If the water supply is below the centerline of the pump, the distance is negative suction head, or suction lift. If the water supply is above the centerline of the pump, it is known as positive suction head. The illustration shows both positive and negative suction heads of 20 feet. Atmospheric pressure and the ability of the pump to pull a vacuum limit negative suction head. At sea level the absolute maximum negative suction head is 33.8 feet. For most pumping applications negative suction heads should never exceed 20 feet.

### **3. Determine the discharge head:**

The discharge head is the vertical distance from the centerline of the pump to the overflow of the storage tank. The illustration shows a discharge head of 60 feet.

### **4. Determine the total head:**

The total head can be determined by adding a negative suction head to the discharge head or by subtracting a positive suction head from the discharge head.

### **5. Determine the friction loss:**

The total head represents the vertical distance that the pump must lift the water. The horizontal distance the water must move will also impact the pressure against the pump. As water moves through a pipe, it rubs against the inside of the pipe. This creates friction that will reduce the available pressure at the end of the pipe.

A pump must produce a pressure higher than total head to overcome this friction loss and still lift water at its rated flow. There are four factors to consider when determining friction loss. They are the size of the pipe, the flow through the pipe, the length of the pipe, and the "C factor". The "C factor" is also known as the coefficient of friction. It represents the roughness of the inside of the pipe wall.

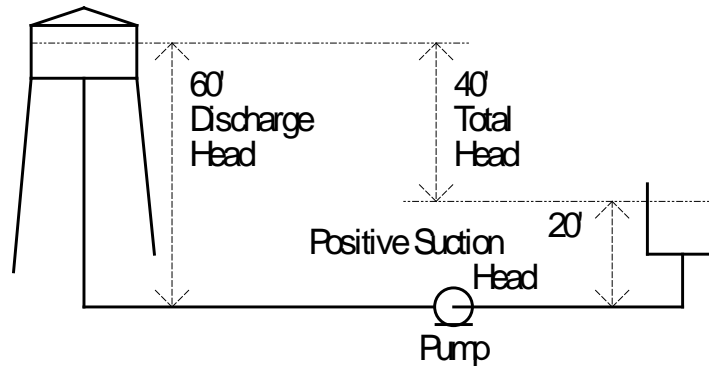

$$\text{Total Head} = \text{Discharge Head} - \text{Positive Suction Head}$$

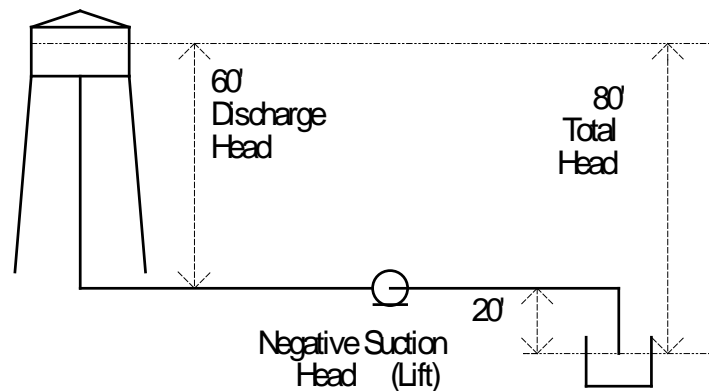

$$\text{Total Head} = \text{Discharge Head} + \text{Negative Suction Head (Lift)}$$

## 6. Determine the Total Dynamic Head

Once the friction loss has been determined, it is added to the total head to calculate the total dynamic head. The total dynamic head, or TDH, is the head at which the pump should be rated. The pump can now be sized for the correct flow and the total dynamic head that it must work against.

$$\text{T.D.H.} = \text{Discharge Head} \pm \text{Suction Head} + \text{Friction Loss}$$

### PUMP CHARACTERISTIC CURVES

Every pump has certain characteristics under which it will operate efficiently. These conditions can be illustrated with pump characteristic curves. The graph of the pump curve should show:

- 1) The head capacity curve (A)
- 2) The brake horsepower curve (B)
- 3) The efficiency curve (C).

The graph may contain a curve labeled NPSH, for Net Positive Suction Head, instead of a brake horsepower curve.

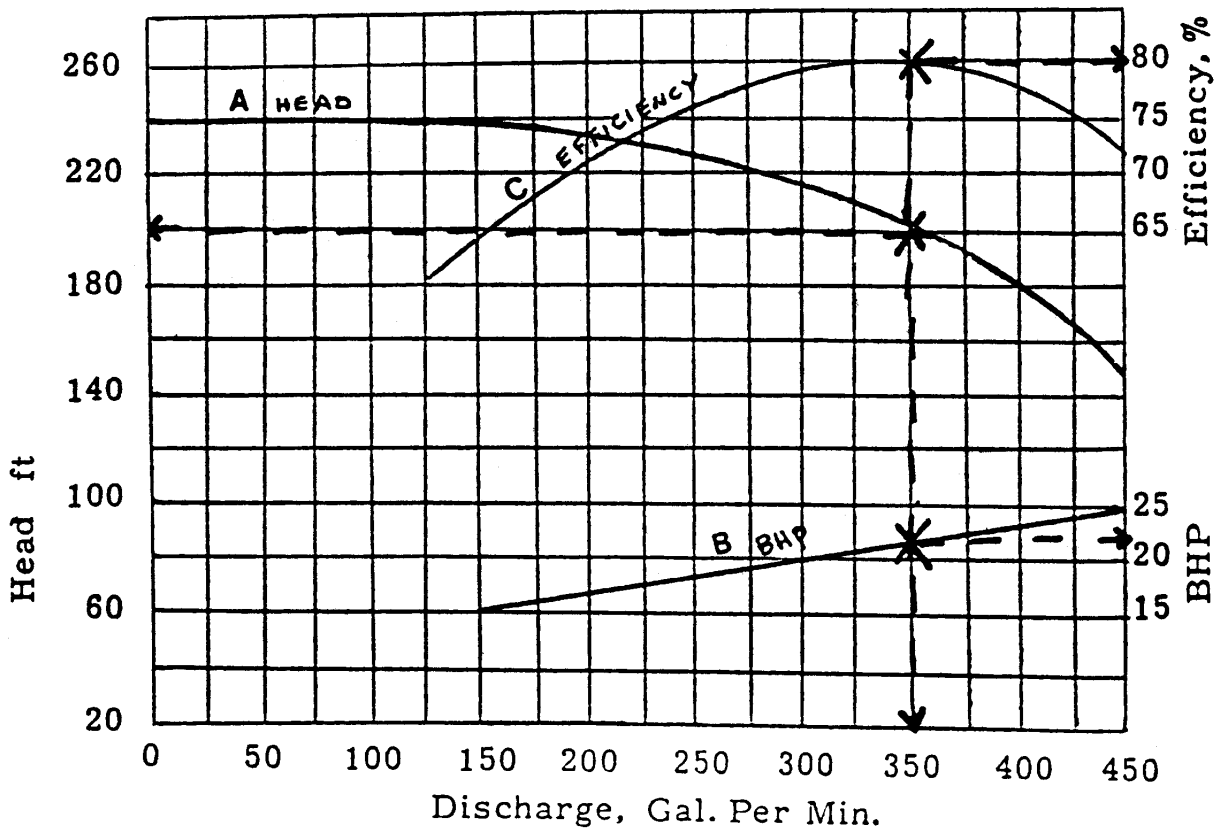

PUMP CURVE

To use the pump curve:

1. Start at the particular head pressure that is desired and then travel across the chart to the point where it crosses the head capacity curve (A).
2. Drop a straight line from this point down to the bottom of the chart to determine the gpm output at that particular head pressure.
3. The brake horsepower can be determined by starting at the point where the vertical line crosses the horsepower curve (B) and going across to the right side of the chart. Use the same procedure for NPSH if it is used instead of BHp.
4. The efficiency of the pump at this flow and pressure is determined by starting at the point where the vertical line crosses the efficiency curve (C) and going over to the right side of the chart.

When the head pressure of the pump represented by this curve is 200 feet, the output is 350 gpm. The brake horsepower under these conditions is about 22 BHp and the efficiency is 80%. If the speed of the pump changes all of the pump's characteristics will also change.

If the pressure is increased to 220 feet of head the flow will drop to about 275 gpm. At this point on the curve the BHp requirement drops to 19 brake horsepower and the efficiency drops to about 78%. If the pressure drops to 180 feet of head the flow goes up to 400 gpm. Now the BHp requirement goes up to about 23 brake horsepower and the efficiency again drops to about 78%.

## **SHUTOFF HEAD**

The highest head pressure that the pump will develop is called the shutoff head of the pump. The shutoff head for the pump in this curve is 240 feet of head. When a pump reaches shutoff head, the flow from the pump also drops to zero. This is a valuable piece of information for conducting a quick check of the pump's performance. If the pump cannot generate its rated shutoff head, the pump curve is no longer of any real value to the operator. A loss of shutoff head is probably caused by an increase in recirculation inside the pump due to worn wear rings or worn impellers.

There is another factor that might affect the shutoff head of the pump. The pump curve assumes that the pump is running at design speed. If a pump that is supposed to spin at 1750 rpm and it is only turning at 1700 rpm, the shutoff head will be lower than the pump curve too. However, if the pump speed is checked with a tachometer and found to be correct, the wear rings or impellers are probably in need of repair.

## CHECKING SHUTOFF HEAD

It is fairly easy to check the shut-off head on a pump if it has suction and discharge pressure gauges:

1. Start the pump and close the discharge isolation valve. This will create a shut-off head condition since the flow has been reduced to 0 gpm. The pump should not operate at shut-off head for more than a minute or it will begin to overheat.

**NOTE:** NEVER attempt to create shutoff head conditions on a multi-staged turbine well. The shutoff head may be several hundred feet higher than normal operating pressure, which can cause damage to piping.

2. With the pump running at shutoff head, read the suction and discharge pressure gauges. Subtract the suction pressure from the discharge pressure to get the shut-off head. Compare the field readings to the pump curve to see if the wear rings are in need of replacement.

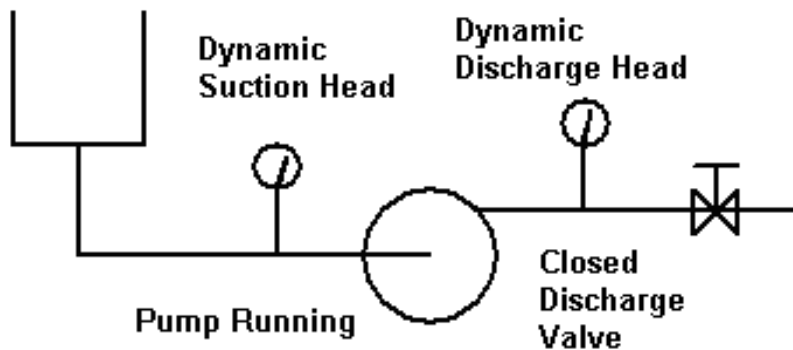

### SHUTOFF HEAD = DYNAMIC DISCHARGE HEAD - DYNAMIC SUCTION HEAD

If the shutoff head matches the curve, the same calculation can be used, when the pump is running normally, to estimate the Total Dynamic Head (TDH) and determine the flow when a meter is not available.

## NET POSITIVE SUCTION HEAD

There is a minimum suction pressure required to move water into the pump at the rated flow. This value is known as the Net Positive Suction Head (NPSH). It is the pressure on the suction side of the pump when it's running. If a pump is allowed to run with the suction pressure below the required NPSH it will cavitate. It is important to always make sure the "Stop" level switch in the storage tank is set above the minimum NPSH requirement.

## COMMON OPERATIONAL PROBLEMS

The operator should check all pumps and motors every day to insure proper operation. After spending a certain amount of time with these pumps and motors an operator should be able to tell just by listening to them whether they are working properly. The vast majority of pumping problems are either a result of improperly sizing a pump for the job or one of the three following operational problems.

### CAVITATION

One of the most serious pumping problems an operator will encounter is cavitation. It can be identified by a noise that sounds like marbles or rocks are being pumped. The pump may also vibrate and shake to the point that piping is damaged in some severe cases. Cavitation occurs when the pump attempts to discharge water faster than it can be drawn into the pump. This situation is normally caused by the loss of discharge head pressure or an obstruction in the suction line. When this happens a partial vacuum is created in the impeller causing the flow to become very erratic. These vacuums are formed on the backside of the impeller vanes.



As the water surges into the impeller the vacuum collapses. These cavities form and collapse several hundred times a second. As they collapse, they draw the water behind them into the impeller at the speed of sound. The impact created by the water slamming into the impeller is so great that pieces of the impeller are eventually chipped away. The impeller on the left has been damaged by cavitation

When cavitation occurs immediate action must be taken to prevent the impeller, pump and motor bearings, and piping from being damaged. Cavitation can be temporarily corrected by throttling the discharge valve. This action prevents damage to the pump until the cause can be determined and corrected. Remember that the discharge gate valve is there to isolate the pump, not control its flow. If it is left in a throttled position the valve face will become worn to the point that it won't seal when the pump must be isolated for maintenance.

#### CAUSES OF CAVITATION

- Loss of Discharge Pressure
- Closed Suction Valve
- Low Suction Head Due to Drop in Water Level
- Obstruction in the Suction Line

## **AIR LOCKING**

Air locking is another common problem in centrifugal pumps. It occurs when air or other gases becomes trapped in the volute of the pump. As the gas collects it becomes compressed and creates an artificial head pressure in the pump volute. As more air collects in the pump the pressure will continue to build until a shutoff head condition is reached.

Air locking is most often caused by leaks in the suction line. Pumps that are rotated in and out of service each week may become air locked when anaerobic decomposition releases sewer gases in the pump. The failure of a low level shutoff switch, allowing air in from the wet well, may also cause air locking.

An air locked pump will overheat in a matter of minutes. The shutoff head condition means that no water is moving through the pump. Vertical pumps that use internal leakage to cool packing may also experience packing ring failure since the trapped air can prevent water from reaching the packing.

Air relief valves are used to prevent air locking. They are located on the highest point on a water pump volute and automatically vent air as it accumulates in the pump. Wastewater pumps have manual bleeder valves. Always repair leaking gaskets and joints on the suction piping. If the pressure in the line drops below atmospheric pressure when the pump is running, air will leak in instead of water leaking out.

## **LOSS OF PRIME**

Loss of prime occurs when water drains out of the volute of the pump. The impeller can't create any suction at the impeller eye unless it is filled with fluid. This occurs only when negative suction head conditions exist. Pumps that operate with negative suction head are usually installed with a foot valve or check valve at the bottom of the suction pipe. This valve holds the water in the suction pipe and pump when the pump is off.

When a pump loses its prime it must be shut down, reprimed, and all the air bled out of the suction line before starting the pump again. Worn packing and a defective foot valve normally cause loss of prime. The best way to prevent loss of prime is to always design a pump installation with positive suction head on the pump.

## **CENTRIFUGAL BLOWERS**

Centrifugal blowers used in aeration systems operate on the same principles as a centrifugal pump. They must move air to avoid overheating. The airflow drops as the pressure against the blower increases. They will also cavitate. This is why it is important to clean and replace intake filters as they get dirty. It is also why the suction valve should never be throttled. The discharge can be throttled using shims as long as the reduction in airflow does not cause overheating. Air filters on blowers need to be replaced before the pressure drop across the dirty filter restricts the airflow to the point that cavitation can occur. Large air handlers have a pressure differential indicator on the intake filter to indicate when it is time to change the filter element.

**BASIC STUDY QUESTIONS**

1. What kind of load creates wobble as the shaft spins?
2. Where are wearing rings found in a pump?
3. What are the three factors that are needed to determine total dynamic head?
4. What device is used to prevent air locking in a pump?
5. What is shutoff head?
6. What happens when you increase the pressure on a centrifugal pump?
7. What are some of the possible causes of cavitation?
3. Air trapped in the volute of the pump will cause:
  - A. Cavitation
  - B. Air locking
  - C. Loss of prime
  - D. All of the above
4. Which type of pump would be used in a lift station?
  - A. Vertical turbine centrifugal
  - B. Split case horizontal centrifugal
  - C. End suction centrifugal
  - D. Positive displacement
5. If the pressure against a positive displacement pump increases:
  - A. The flow increases
  - B. The flow decreases
  - C. The flow stays the same

**BASIC SAMPLE TEST QUESTIONS**

1. A lantern ring:
  - A. Must be located in line with the seal water port
  - B. Is used to direct cooling water to the center of the stuffing box
  - C. Will be found in the stuffing box
  - D. All of the above
2. The discharge piping of a centrifugal pump will be larger than the suction piping.
  - A. True
  - B. False
6. Pump packing must leak a little.
  - A. True
  - B. False
7. Priming a pump means:
  - A. Starting it slowly
  - B. Draining it
  - C. Filling the volute with water
  - D. None of the above
8. Pumps are usually rated to run at the most efficient point on the pump curve.
  - A. True
  - B. False

### ADVANCED STUDY QUESTIONS

1. What does the term “C factor” refer to?
2. What is the best way to prevent loss of prime?
3. What are four conditions that could cause cavitation in a centrifugal pump?
4. What kind of information is found on a pump curve?
5. What is NPSH?

### ADVANCED SAMPLE TEST QUESTIONS

1. The maximum pressure a centrifugal pump can generate is called:
  - A. Shutoff head
  - B. Total dynamic head
  - C. Total head
2. Negative suction head should never exceed:
  - A. 10 feet
  - B. 20 feet
  - C. 30 feet
  - D. 40 feet
3. Which of the following would make a centrifugal pump stop cavitating?
  - A. Throttle the suction valve
  - B. Throttle the discharge valve
  - C. Decrease the TDH
  - D. Decrease the NPSH

4. Which of the following will not cause cavitation?
  - A. Low discharge pressure
  - B. Throttling the suction valve
  - C. Low water level in the wet well
  - D. High discharge pressure
5. When a pump runs at shutoff head:
  - A. The flow increases
  - B. It will overheat
  - C. It vibrates
6. How can you prevent loss of prime?
  - A. Air release valves
  - B. Maintain negative suction head
  - C. Maintain positive suction head
7. A dirty air filter on a centrifugal blower can cause:
  - A. Overheating
  - B. Cavitation
  - C. Vibration
  - D. All of the above

## MAINTENANCE AND INSTRUMENTATION

Collection systems and wastewater treatment plants are expensive to build and maintain. A maintenance program is essential to insuring that the mechanical components of the system stay in good working order and provide the longest possible service life. A preventive maintenance schedule should be maintained to make sure that each piece of equipment gets the proper attention. Most preventive maintenance consists of inspecting, cleaning, and lubricating the equipment. The equipment operators can usually complete these tasks. Specially trained personnel that possess the necessary mechanical skills should handle major maintenance tasks like component replacement or overhaul.

### PUMP MAINTENANCE

The most common piece of equipment in a wastewater system is the centrifugal pump. There are several maintenance procedures that must be performed periodically for any centrifugal pump. Pump packing wears out, bearings must be lubricated or replaced, mechanical seals need replacing, couplings must be maintained and motor and pump shafts must be aligned. These procedures are not difficult to learn. Some of the procedures may require the use of a few special tools. Once an operator understands the basic procedures and has a chance to put the theories into practice, it doesn't take long to become proficient at each task.

### PUMP PACKING

Pump packing is one of the biggest problem areas for operators in charge of pump maintenance. Poor maintenance of pump packing is responsible for more pump damage than any other maintenance item. Poorly maintained packing can cause several problems including:

#### DAMAGE CAUSED BY PACKING FAILURE

- Loss of prime with negative suction head
- Shaft and sleeve damage
- Water contamination of bearings

The most common type of pump packing comes in a square braided stock. There are a number of different kinds of braided packing. It can be manufactured from jute, asbestos, nylon, Teflon or other synthetics. It can be lubricated with graphite, grease, or other synthetic lubricants such as Teflon. Prices for packing range from several dollars a pound for graphite impregnated nylon to hundreds of dollars a pound for pure Teflon and other synthetics.

A rule of thumb is to buy the most expensive packing that you can afford, provided that you are taking care of the rest of the pump properly. If scored or damaged shaft sleeves and out of round or bent shafts are not going to be repaired, use the cheapest packing you can get. Expensive packing will not last any longer than the cheap stuff if the sleeve is scored or the shaft is bent. If the rest of the pump is properly maintained, the more expensive types of packing will last several times longer than the cheap packing and will usually pay for itself with a longer service life.

## **REMOVING OLD PACKING**

It's time to replace the packing when there is no more adjustment left in the packing gland and there is too much leakage from the stuffing box. When this occurs, all of the packing rings must be replaced. Adding an additional ring or just replacing one or two rings will only lead to premature packing failure and damage to the shaft and sleeve. Use the following procedure to remove the old packing:

1. Tag the pump in the "OFF" position and lock it out so that it can't be accidentally restarted. Always try to start the pump to insure it is properly isolated.
2. Isolate the pump by closing the suction and discharge valves.
3. Drain the pump by opening the drain cock or removing the drain plug in the bottom of the volute.
4. Remove the packing gland. If it is not split so it can be removed, it should be tied off so that it is out of the way.
5. Remove the packing rings with a packing puller. It looks like corkscrew on the end of flexible T-handle. Take care not to score the shaft sleeve.
6. Measure the distance to the lantern ring and then remove it with the hooks made from stiff wire. If the lantern ring is split, it can be removed from the shaft. If you're not sure the lantern ring was in the right place to begin with measure the distance from the face of the stuffing box to the seal water port or refer to the vendor's engineering drawing of the stuffing box for the correct position.
7. Remove the remaining packing rings and clean the stuffing box and shaft.
8. Disconnect, inspect, and clean the seal water line and seal water port.
9. Inspect the shaft or shaft sleeve. If it is scored or grooved, the pump should be dismantled and the shaft dressed or repaired by a machine shop.

## REPACKING THE PUMP

Before new rings are cut it is important to determine the size and number of packing rings that are needed for the stuffing box. This information should be available in the vendor's engineering drawings. If these drawings are not available, measurements of the stuffing box and shaft can be used to make the determination. The correct packing size is determined using the following procedure:

1. Measure the inside diameter of the stuffing box and the outside diameter of the shaft.
2. Subtract the shaft diameter from the stuffing box diameter.
3. Divide the difference by two.

The correct number of rings can be determined using the following procedure:

1. Measure the depth of the stuffing box.
2. Divide the depth of the stuffing box by the size of the packing to get the total number of rings.
3. Subtract one from this total if a lantern ring is used in the stuffing box.

Once the size and number of rings has been determined, the new packing can be cut and installed. Great care should be taken to keep the packing material clean and free from dirt. Packing spools should be stored in plastic bags to prevent contamination. Dirt and grit in the packing rings will lead to serious shaft and sleeve damage. The two most important aspects of cutting packing rings involve cutting them the right length and cutting them so the ends will butt together squarely.

Cut and replace the packing rings using the following procedure:

1. Cut the packing to the proper length and shape using a very sharp knife or carton cutter. Wrap the packing material around the shaft, an old sleeve, or even a piece of hardwood turned to the proper diameter. Cut all of the rings at once with the packing on the shaft to insure that the ends will butt together squarely.
2. Wrap each ring of packing around the shaft and seat it in the stuffing box completely before adding the next ring. Open the ring by twisting it instead of pulling the ends apart. A light coat of grease on the outside of the ring will make it much easier to push into the stuffing box. Stagger the joints of the rings so that they are 90 degrees apart. Make sure the lantern ring lines up with the seal water port.
3. Install the packing gland. Make sure the gland is tightened down evenly.

## ADJUSTING THE PACKING GLAND

The final adjustment of the packing gland is made while the pump is running. The pump can be restarted once the locks and tags have been removed and the discharge and suction valves are completely opened. Vent air from the air release valve to insure the pump is primed.

More packing jobs have been ruined by improper gland adjustment than any other single reason. Adjust the packing gland using the following procedure:

1. Tighten the gland one half turn a time on each side until it just begins to put pressure on the packing.
2. Start the pump and tighten the gland until the flow of water is reduced just enough to prevent flooding the drain line. Allow the pump to run for at least five minutes while the packing rings begin to seat. Never allow the packing to get hot during this break in period.
3. After five minutes, adjust the packing slowly until the leakage is reduced to the desired level. The appropriate amount of leakage will vary with the size of the pump and type of packing, but a general rule of thumb is 20-60 drips per minute. Tighten the gland and check the water temperature periodically. When the water turns lukewarm there is not enough flow to cool the packing properly.

Loosen the packing gland just enough to cool the water back down to room temperature. The packing gland will probably need to be checked again as the packing rings get properly seated. This may have to be done several times over the next 24 hours of run time.

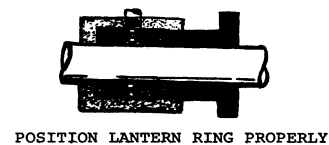
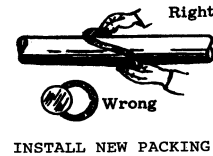
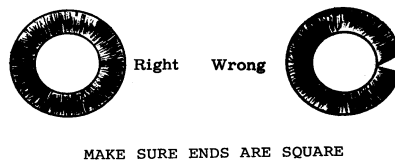
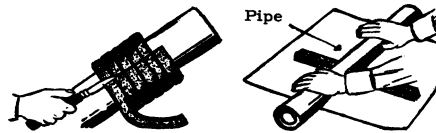
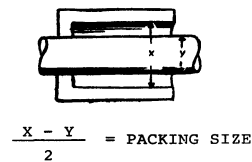
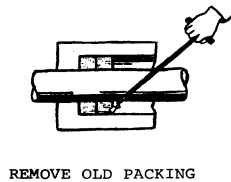

## BEARING MAINTENANCE

Proper bearing lubrication is a critical part of getting the proper service life out of pump and motor bearings. As strange as it may sound, more bearings have failed from over-lubrication than from lack of lubrication. In fact, some bearings never require lubrication and may fail if they are greased. Shielded and sealed bearings have sufficient lubricant to last the life of the bearing. Shielded bearings have a metal skirt that is attached to the outer race. It covers the rollers but doesn't touch the inner race. Sealed bearings have a rubber skirt that does touch the inner race. Bearings that do require periodic grease lubrication use a surprisingly small amount of grease when compared to the bearing housing size. A properly greased bearing will have a bearing housing that is never more than twenty five to thirty percent full. The grease is responsible for lubricating and cooling the bearing.

Grease that is inside the bearing will get hot as the bearing heats up. When the grease gets hot it becomes more fluid and is thrown out of the bearing and onto the wall of the bearing housing, where it cools. Grease that is outside the bearing is drawn into the race where it again heats up and is thrown out. This process keeps the bearing lubricated and removes heat from the bearing. If the bearing housing is full of grease there is no way for the hot grease to get out of the bearing. The lubricant inside the bearing overheats and breaks down. The grease will build up in front of the rollers and prevent them from rolling. Then they slide around the race and generate even more heat. This condition is called churning.

As bearings heat up and cool down the races and rollers expand and contract. Bearings are heat stabilized to 250°F. This means when they cool down they will assume their original dimensions as long as the temperature does not rise above 250°F. This is the reason small electric motors should not operate above 220°F or 105°C. Lubrication schedules for low-speed (under 2500 rpm) anti-friction bearing applications are based on the operating temperature of the bearing. Always refer to the vendor recommendations for the proper lubricant and lubrication frequency.

## COUPLINGS

Couplings connect the motor shaft to the pump shaft. The exception to this would be a close-coupled pump. A close-coupled pump will have the impeller mounted directly to the motor shaft. Couplings can be rubber or steel. Steel couplings are most commonly gear-type or grid couplings.

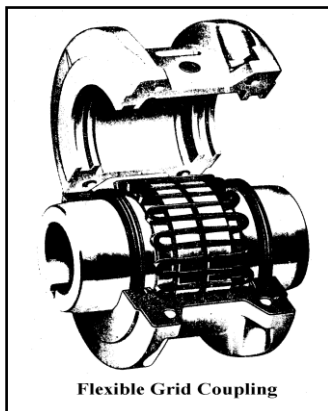

Couplings are mounted and removed by pressing or heating the coupling. They should never be mounted using a hammer. The halves of the coupling should be separated by a gap large enough to accept the thermal expansion as the shaft and motor heat up. Couplings flex as the two shafts spin. This movement generates friction and heat in the coupling and requires grease lubrication. The main problem with lubrication in a coupling is centrifugation. As the coupling spins, it tries to throw the grease out of the housing.

Couplings should be inspected periodically. The grease is changed the same way a bearing is lubricated. Broken or worn teeth and wear or pits on the grids are indicators that the coupling should be replaced. This type of wear occurs in a coupling when it is misaligned. Gear-type housings are usually made of cast material. The housing bolts must be tightened carefully in a crossing pattern to avoid cracking the assembly.

## MOTOR ALIGNMENT

Maintenance of electrical equipment is important in order to reduce downtime and maintain proper process control in wastewater facilities. One of the most important parts of equipment maintenance involves aligning the motor to the driven equipment.

If the pump and motor shafts are not aligned properly, the result will be vibration and subsequent damage to the pump coupling, mechanical seals, and the pump and motor bearings. Misalignment can be angular and parallel or offset. Angular misalignment means that the motor is crooked when it lines up with the pump shaft. Parallel misalignment means that the shafts are in a straight line but one of them is too high or too low. Misalignment can also be in the horizontal plane, requiring a side-to-side movement of the motor. It can also be in the vertical plane, requiring raising the motor with shims. This means that measurements must be taken at the top, bottom, and both sides of the coupling.

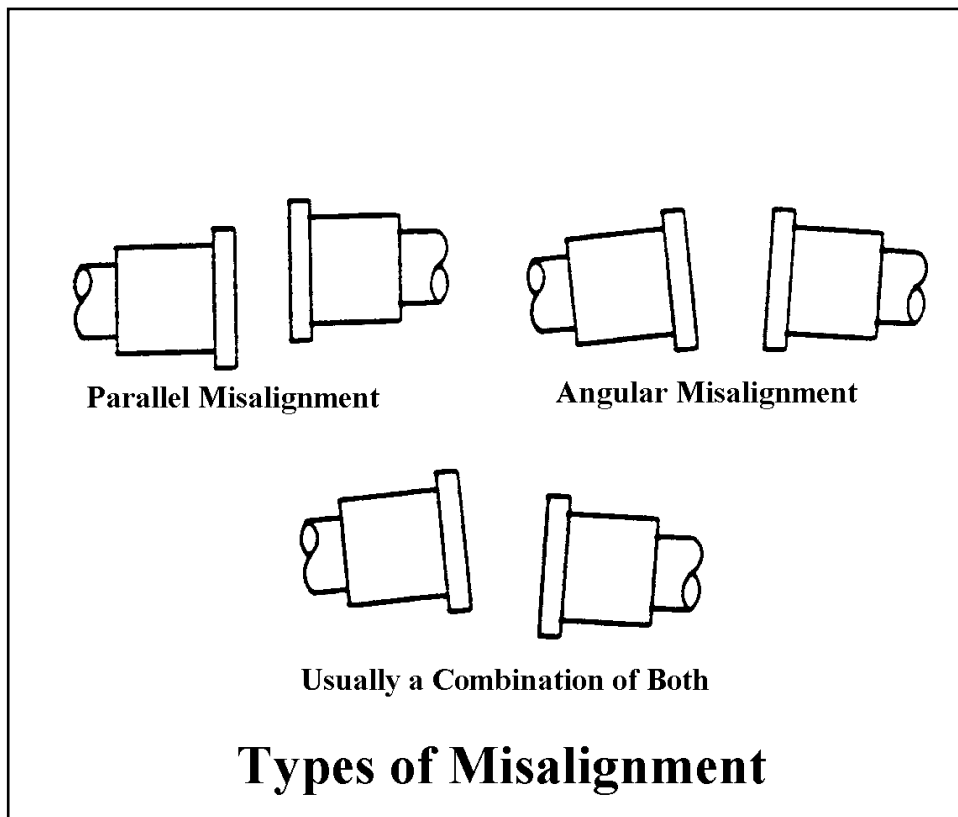

A crude check of the misalignment can be done using a straight edge and feeler gauge on the coupling halves. A dial indicator or laser system can be used to more accurately gauge the amount of offset or angularity. These methods are capable of precise measurements down to one thousandth of an inch.

## **ELECTRIC MOTORS**

Very few operators do electrical repairs or trouble shooting because this is a highly specialized field and unqualified operators can seriously injure themselves or damage costly equipment. For these reasons the operator must be familiar with electricity, know the hazards, and recognize his own limitations when working with electrical equipment. Most wastewater systems hire a licensed electrician for major problems.

Electric motors are used to convert electrical energy into mechanical energy. A motor consists of a stator, a rotor, end bells, and field windings. Most large motors will be three phase motors rated from 220 or 4160 volts.

Electrical terms like watts and volts have counterparts in fluid hydraulics. Voltage is the electrical equivalent to hydraulic pressure. Hydraulic pressure is measured in psi and electrical pressure is measured in volts. The electrical equivalent of friction loss is resistance or ohms. Hydraulic flow is measured in gpm and electrical current flow is measured in amps. Hydraulic horsepower is determined by multiplying flow by the pressure. The electrical equivalent of horsepower is a watt. Watts are determined by multiplying amps by the voltage.

## **PHASES**

The term phase applies to alternating current (AC) systems and describes how many external winding connections are available from a generator, transformer, or motor for actual load connections. Motors are either single phase or three phase.

## **SINGLE PHASE MOTORS**

Single-phase motors are normally operated on 110-220 volt AC single phase systems. A straight single phase winding has no starting torque so it must incorporate some other means of spinning the shaft. A single phase motor requires a special start circuit within the motor to make sure it runs in the right direction. Several different types of starter windings are available in these motors. Single phase power leads will have three wires, like a three-prong extension cord. The third wire is the ground.

## **THREE PHASE MOTORS**

Three phase systems refer to the fact that there are three sets of windings in the motor and three legs of power coming in from the power grid. This type of motor is used where loads become larger than single phase circuits can handle. Three phase power is also more efficient than single phase power. With three legs to carry power more amps can be delivered to the motor.

Vertical turbine pumps have hollow core motors. The shaft slides into the rotor. Impeller clearance is adjusted by raising and lowering the shaft. This is accomplished by tightening or loosening the adjusting nut or thrust nut on the top of the motor. This procedure is called a lateral adjustment.

The squirrel cage induction motor is widely used because of its simple construction and relative low maintenance requirements. The windings are stationary and are built into the frame of the motor. The power supply is connected to the windings in the stator which creates a rotating magnetic field. The rotor is made up of bars arranged in the shape of a cylinder that resembles a squirrel cage. Squirrel cage induction motors make up approximately 90% of all motors used in industry today.

A megger is a device that is used to determine the condition of the insulation in the motor windings of a squirrel cage motor. It produces a very high voltage used to check for potential weaknesses in the insulation. It is the electrical equivalent of a pressure test on a water or sewer pipe. The megger generates hundreds of thousands of volts of electrical pressure, but no current.

Three-phase motors do not use a start circuit. The direction of rotation is determined by how the three leads are wired to the motor. If any two of the leads are switched, the motor rotation will be reversed.

## **SINGLE PHASING**

Anytime a lead becomes grounded, a dead short develops, or one set of the contacts opens in a three phase motor, single phasing will result. When this occurs, the speed of the motor will drop and it will begin to overheat. The single phase will draw too many amps and it will quickly burn up. When single phasing occurs while the motor is not running, it simply will not start up again. Special circuit protection is available that will shut the motor off if single phasing occurs.

## **CIRCUIT PROTECTION**

Motors need to be protected from power surges and overloads. Fuses and circuit breakers are designed to open the circuit when the current load threatens to damage the motor. Fuses are generally sized at 120-150% of motor capacity. Circuit breakers can be reset when they trip, instead of being replaced like a fuse. Circuit breakers can react faster than fuses and are usually sized closer to the current rating of the motor. They are normally found on single phase 110 or 220 volt motors.

## **CHEMICAL FEED SYSTEMS**

Chemical feeders are necessary to assure that the proper amount of each chemical is added to the water on a continuous basis. Each feeder must have chemical storage, a device that feeds the chemical into a solution tank where it is dissolved, and a delivery system to add the chemical at the proper point in the treatment process. Chemical feeders are either gravimetric or volumetric. Gravimetric feeders usually have a conveyor that uses a set of scales to maintain a constant weight of material on the belt. They are not used in wastewater treatment because most treatment chemicals are corrosive and will damage the scale mechanism. Volumetric feeders are more common. The most common type of volumetric feeder is the positive displacement reciprocating diaphragm pump.

Volumetric dry chemical feeders must be calibrated. The first step is catching and weighing the feed chemical at different speeds and converting the weights to pounds per day. This data can be used to create a feed rate table for that particular feed machine. The feed chamber must be cleaned routinely in order to maintain accurate feed rates.

Chemical feed pumps are positive displacement pumps. They are usually diaphragm pumps, but peristaltic pumps are becoming popular for very small systems. The major components of a peristaltic pump include a circular pump head that contains a piece of flexible tubing and a roller assembly. As the pump motor turns the roller, fluid is squeezed out of the tube. These pumps can meter flows as low as 3-4 drips per minute (0.1-0.15 ml/min).

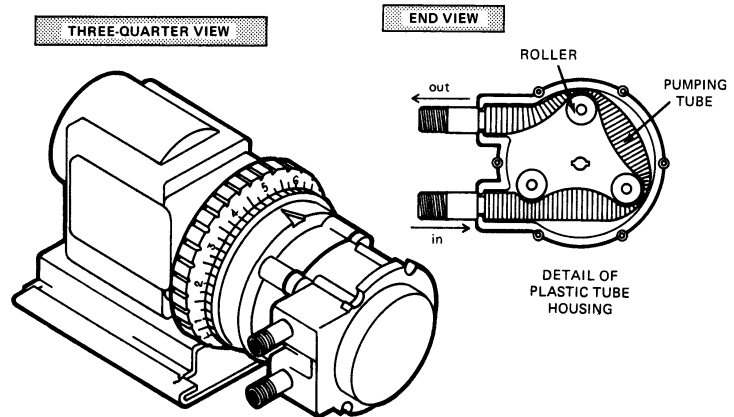

Peristaltic Pump

The components of a diaphragm feed pump include a diaphragm driven pump chamber, and suction and discharge check valves. The check valves, that provide the one way flow through the pump, can get clogged with grit, scale, or lime deposits. The strainer on the pump suction line should be located several inches above the bottom of the solution tank to prevent lime and grit from being drawn into the pump and fouling the check valves.

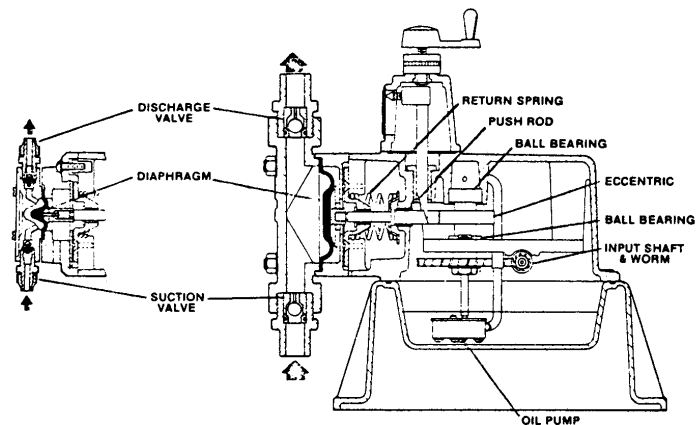

Diaphragm Pump

If the check valves get fouled, the pump will not pump any solution. Flushing the line with clean water or a weak acid, like vinegar, may also correct the problem. In severe cases the valves may have to be disassembled and cleaned. Always make sure the pump is primed before putting it back into service. It may also be advantageous to locate the pump so that it has a positive suction head.

## PROCESS INSTRUMENTATION

There are two basic types of instrumentation in most mechanical processes. There are instruments that are digital in the sense that they are controlling processes that are either on/off or open/closed types of operations. A pump start circuit can be controlled by a simple switch that turns the pump on or off when the water reaches a certain level in a tank. These systems use probes or mercury float switches to send signals to the pump.

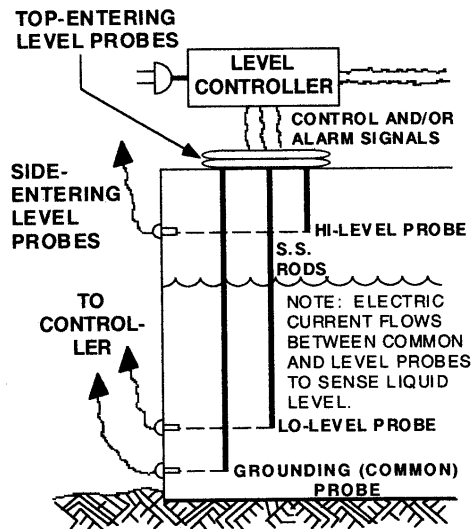

### Electrode Level Control System (Digital)

Reproduced by permission of California State University, Sacramento Foundation Water Treatment Plant Operation Volume 2

Float switch systems are used primarily in lift stations. As the float rises or falls with the water level, high level or low level switches are tripped activating the pump control circuit. This type of level control will have to be checked on a regular basis to prevent malfunctions.

Alarm sensors are also digital devices. They open a circuit and stop a piece of equipment when a preset alarm condition occurs. These protective devices can monitor temperatures, pressures, vibration and electrical conditions in the system and shutdown equipment when values are outside acceptable ranges.

The other kind of instrumentation makes use of analog devices. Analog instruments produce a value that can be displayed remotely. Pneumatic systems that use air bubblers and pressure transducers are analog devices that can be used to monitor water levels. Flow meters are another example of analog instrumentation.

Float systems are usually located inside a conduit or stilling well. The stilling well keeps the float from becoming tangled on interior supports. Bubbler systems and pressure transducers can be located outside the tank where they are easier to maintain and calibrate.

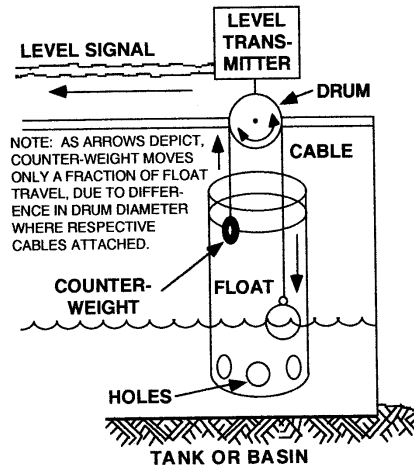

### Float System Level Controls (Analog)

Reproduced by permission of California State University, Sacramento Foundation Water Treatment Plant Operation Volume 2

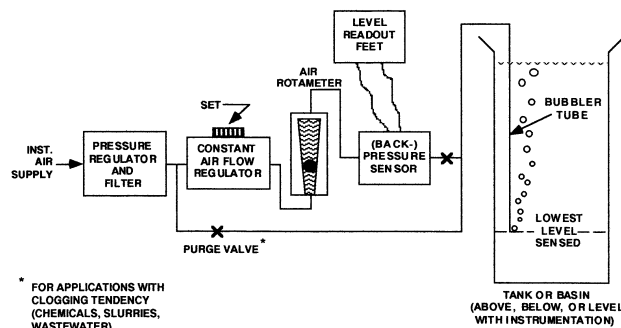

FUNCTIONAL DIAGRAM

### Bubbler System Level Controls (Analog)

Reproduced by permission of California State University, Sacramento Foundation Water Treatment Plant Operation, Volume 2

Pressure sensing controls are normally located near the bottom of the storage tank. This type of control is activated by the amount of head pressure in the tank. As the pressure increases, a spring or metal band is expanded tripping a micro switch or a mercury switch that then activates the pump. The on and off levels on these switches are set by applying or decreasing the tension on the spring, or by setting manual control points on a dial for the mercury switch. These switches must be protected from freezing and extreme vibrations for proper operation. Pressure transmitters can also be used to control multiple wells or pumps and the signal can be converted into a tank level reading.

Other examples of analog instrumentation include flow controllers and chemical feed systems. A flow meter sends a flow signal to a recorder and a device controller. The controller changes the valve position (as seen below) or the speed of a variable speed pump.

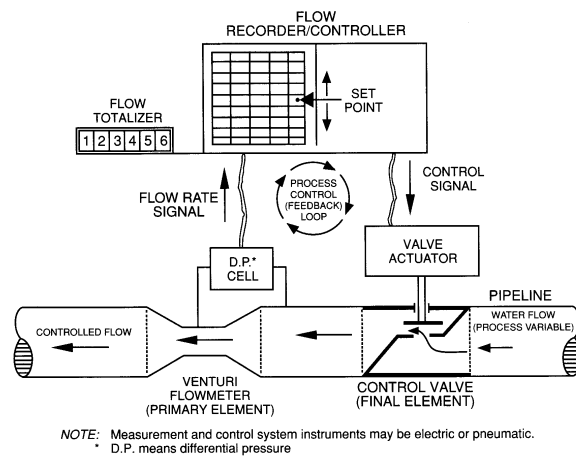

## Flow Control Instrumentation Loop

Reproduced by permission of California State University, Sacramento Foundation Water Treatment Plant Operation Volume 2

### INSTRUMENTATION LOOPS

Instrumentation is usually set up as either a “feed forward” or a “feedback” loop. An example of a feedback loop would be a venturi flow meter sending a signal to a control valve in order to maintain a set flow rate. The meter would be located downstream of the control valve and would feed a signal back upstream to the control valve. Another example of a feedback loop would be a chlorine analyzer changing the chlorine dosage based on a change in residual downstream of the chlorinator. It would be located downstream and feed the information back to the chlorinator.

Three things determine the rate at which an instrument makes a change in the process. One is the amount of change for each reading. This is referred to as the span. Another is how often readings are taken. This is called the rate. The third is the dead band. Dead band means that there is a range around the set point where no action is taken. For instance, a chemical feed instrument may be set to maintain a pH of 7.0. But the dead band may be set so that no action is taken until the pH rises to 7.2 or falls below 6.8. If the rate is too fast or the span too large, the process conditions may fluctuate as the instrumentation “hunts” for the set point.

Instrumentation loops commonly operate with a 4-20 milliamp signal range. The instrument sends a signal between 4 and 20 milliamps to the controller. The controlling device will then convert the milliamp signal into a 0-100% value for the process variable. If a 4ma signal is sent, it represents a 0% or off condition. A 20ma signal represents a 100% condition. A signal between 4 and 20 milliamps is converted into the appropriate percentage variable by subtracting 4 from the signal and dividing the difference by the 16ma span of the signal. For example, an 8ma signal represents a 25% process value ( $8-4=4$  and  $4/16=25\%$ .) A 14.3ma signal represents a 64% value ( $14.3-4=10.3$  and  $10.3/16=64\%$ .)

## **SCADA SYSTEMS**

Many large and small systems are controlled by computerized SCADA systems. SCADA stands for Supervisory Control and Data Acquisition. The SCADA system is comprised of a central control computer and a number of satellite processors at different points in the processes at a wastewater treatment plant. The satellite processors are known as Remote Terminal Units (RTU.) The central computer will contact each remote terminal unit by radio or telephone every twenty to thirty seconds. The RTU will upload any new data at its location to the central computer. The central computer will log the data for future access and decide if any new equipment actions should be taken.

If new action is required, the central computer will issue a command to the RTU. The RTU will be responsible for initiating a startup or shutdown sequence for the equipment or change a control adjustment. The central computer cannot start pumps or open valves. It can only issue the supervisory command to the RTU. The other part of SCADA system, the data acquisition part, includes logging each data point or process variable in a database. This information can be archived or accessed to evaluate system conditions or control responses for the control system.

Security issues for SCADA systems include the need to backup the database to a separate secure hard drive regularly. This is important because the data may be needed to reload and restart the system if it should crash. Access to the system must also be protected by passwords, encrypting data, and firewalls. Wireless systems that rely on radio transmission to relay data are more susceptible to security breaches than hardwired systems.

### **BASIC STUDY QUESTIONS**

1. Why is a preventive maintenance program important?
2. Why would a bearing that has just been lubricated run too hot?
3. What condition would indicate that the pump and motor might be misaligned?
4. What is the most common maintenance problem on a diaphragm or piston pump?

### **BASIC SAMPLE TEST QUESTIONS**

1. Packing must be allowed to drip in order to cool the stuffing box.  
  
A. True  
B. False
2. Which of these statements is true regarding changing pump packing?  
  
A. The joints should be staggered.  
B. All of the rings must be replaced.  
C. The lantern ring must be in line with the seal water port.  
D. All of the above
3. A coupling connects  
  
A. The lantern ring to the packing gland  
B. The impeller to the wear rings  
C. The motor to the pump  
D. The thermal overload to the starter
4. If any two leads on a 3-phase motor are switched:  
  
A. It will run faster  
B. It will overheat  
C. It will run in the opposite direction  
D. Nothing will happen

### **ADVANCED STUDY QUESTIONS**

1. Which pump and motor parts may be damaged by misalignment?
2. Why should fuses be sized for more than the running load amps on the motor?
3. What type of meter measures resistance in a conductor?
4. Why would an instrument hunt for a control setpoint?
5. What does SCADA stand for?
6. Which type of telemeter system is most secure?
7. What is a 4-20ma signal used for?

### **ADVANCED SAMPLE TEST QUESTIONS**

1. Which of these devices is used to test the insulation of motor windings?  
  
A. Amp meter  
B. Volt meter  
C. Ohm meter  
D. Megger
2. When a motor single phases, what is the result?  
  
A. It will run cooler  
B. It will overheat  
C. It will use less energy  
D. It will stop running

3. Which of the following is not an analog instrument?
  - A. Flow meter
  - B. Level indicator
  - C. High level probe
  - D. pH meter
  
4. A pneumatic level sensing system uses:
  - A. A float and tape
  - B. Electrodes
  - C. A bubbler and pressure transducer
  - D. None of the above
  
5. Which of the following is a volumetric feeder?
  - A. Reciprocating pump
  - B. Peristaltic pump
  - C. Auger
  - D. All of the above
  
6. RTU stands for:
  - A. Ready To Use
  - B. Remote Terminal Unit
  - C. Relay Technical Update
  - D. Remote Training Unit



## **SAFETY**

Based on past studies, the water and wastewater industries have the highest injury rates in the nation. Workers in these areas are involved in construction and excavations, confined spaces, hazardous chemicals, and mechanical equipment that pose a serious injury risk when proper training, equipment, and procedures are not utilized. The Occupational Safety and Health Administration (OSHA) is responsible for developing regulations regarding worker safety and protection.

Employers are responsible for providing employees with the proper safety equipment and training in its use. They are also responsible for development and implementation of safety policies for their workplace. The employees, after proper training, are responsible for recognizing the safety issues: following approved safety procedures, and properly utilizing the associated safety equipment.

### **LOCK OUT/TAG OUT (LOTO)**

Lock out/tag out regulations deal with the need to isolate a machine from its energy source to prevent it from starting while work is being done in and around the equipment. Energy sources can include electrical, hydraulic, pneumatic, thermal, and chemical. This can be either active or stored energy. Stored energy can take many forms. Some examples of stored energy are electrical energy stored in capacitors, pneumatic energy stored in a compressor tank, and hydraulic water pressure in an isolated line. Stored energy must be dissipated prior to working on the equipment. Employers are responsible for establishing an Energy Control Plan for LOTO work and supply each worker with their individual LOTO locking devices. Only trained personnel should conduct lock out/tag out procedures.

LOTO requires each worker to attach their personal LOTO lock to the disconnect or isolation device to isolate and de-energize these sources and lock and tag them prior to working on the equipment or process. This assures that the equipment cannot be restarted until each individual is finished with their task and is clear of the equipment.

Any isolation that can be locked must be locked. Lockout devices may also include chains, valve clamps, wedges, jacks, or key blocks. Tags are essentially warnings affixed to energy isolating devices and do not provide the physical restraint provided by a lock. Lockout devices and tag out devices must indicate the identity of the employee.

Anyone who enters a LOTO work area must be informed that a LOTO situation exists. If they are to be involved in the work, they must also apply their own LOTO locks. The employee who applied the device shall remove each lockout or tagout device from each energy-isolating device. If that employee is not available, the supervisor may remove the lock or tag only if reasonable attempts were made to contact the employee. Also, the supervisor must inform the employee as soon as that person returns to work. If equipment must be temporarily restarted, the LOTO must be removed during the restart and reapplied before work can continue.

## **CONFINED SPACE ENTRY**

The water and wastewater industry has one of the highest numbers of confined space injuries per capita in the country. The vast majority of confined space related injuries result in fatalities. Another disturbing fact is that 60% of the confined space related fatalities are people who tried to rescue someone else from a confined space.

A confined space is defined by the following parameters:

- 1) It must be large enough for a person to enter and do work.
- 2) It has openings that make entry or exit difficult.
- 3) It is not intended for continuous occupancy.
- 4) Any open surface tank deeper than four feet.

Confined spaces fall into two categories: permit required and non-permit required. A confined space becomes permit required when it has potential for a hazardous atmosphere, potential for engulfment, a hazardous internal configuration, or other recognized hazards such as dangerous equipment or hot work (welding, cutting torch, etc.) that is in progress.

All employees involved in confined space entries must have the proper training in entry procedures and use of safety equipment. An entry supervisor is responsible for conducting the testing and completing the permit. Atmospheric testing should include oxygen concentration, Lower Explosive Limit (LEL) for explosives, and any toxic gases that may be present. The oxygen concentration must be between 19.5-23.5%. The alarm point for explosives is 10% of Lower Explosive Limit. The alarm point for hydrogen sulfide gas is 10 ppm. The alarm point for carbon monoxide is 35 ppm.

An attendant must be present and stationed outside the confined space to monitor the entrants while they are working. The attendant must maintain constant verbal and visual communications with the entrants. The attendant must also be prepared to instruct the entrants to exit the confined space should the equipment fail or the entrants exhibit impaired judgement.

Any confined space must be tested for a hazardous atmosphere before the entry. Monitoring must continue while the entrants are in the confined space. Permit required confined spaces also require ventilation during the entry and self-contained or supplied air must be used if ventilation fails to produce a safe atmosphere. Permit required confined space entries also require rescue equipment such as a harness and tripod for emergency rescues. If the space is configured in a way that prevents the use of self-rescue equipment, an emergency rescue team must be on-site during the entry. When the entry is completed, the entry supervisor must complete the permit form and file a copy with the appropriate supervisor and a confined space entry master file. Non-permit confined spaces must be reassessed periodically. Any non-permit space can be reclassified, as permit required, based on the results of these assessments.

## **HAZARD COMMUNICATION STANDARD**

OSHA established the Hazard Communication Standard in 1986. The standard was created to provide an information system on hazardous chemicals for both employers and employees. The Haz-Com Standard requires employers to ensure their employees know what hazardous materials exist in the workplace, how to safely use these materials, and how to deal with any emergencies that arise during use. Employers are required to provide the proper safety equipment, train employees in the safe use of any hazardous materials on a jobsite, and maintain records of both.

Producers of hazardous materials are required to provide customers with a Material Safety Data Sheet (MSDS) for each individual chemical or material. MSDS's must be kept on file and available to employees. Employee training should also include how to read and understand the information on the MSDS. The hazards that are involved fall into two basic categories.

---

---

### **TYPES OF HAZARDS:**

- Health Hazards**
- Physical Hazards**

---

---

Health hazards refer to immediate or long-term harm to the body caused by exposure to hazardous chemicals. Physical hazards like flammability or corrosivity can also cause injury to skin, eyes and the respiratory system. MSDS's are divided into eight sections.

---

---

### **Material Safety Data Sheet Sections**

---

---

- 1. Manufacturer's Contact Information**
  - 2. Hazardous Ingredients/Identity Information**
  - 3. Physical/Chemical Characteristics**
  - 4. Fire and Explosion Hazard Data**
  - 5. Reactivity Data**
  - 6. Health Hazard/First Aid Information**
  - 7. Precautions for Safe Handling and Use**
  - 8. Control/Cleanup Measures**
- 
-

## NFPA COLOR-CODE WARNING SYSTEM

Hazardous materials stored in tanks or containers require hazard identification labels for plant workers and other personnel. One method of labeling is the NFPA diamond. The NFPA symbol has four color-coded diamond-shaped sections. The top (red) diamond is the Flammability Hazard rating. The left (Blue) diamond is the Health Hazard rating. The right (yellow) diamond is the Reactivity Hazard rating. The bottom (White) diamond contains special symbols to indicate properties not explained by the other categories. A number-based rating system is used for each section, ranging from 0 – least dangerous to 4 – extremely dangerous. Emergency responders, such as firefighters, can quickly assess the hazard when they arrive at a chemical spill at a facility.

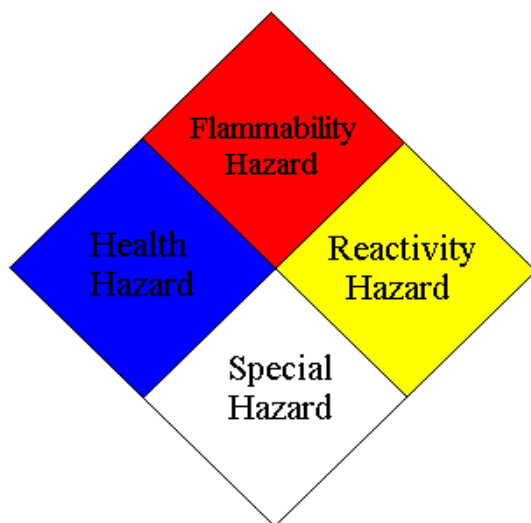

## NFPA Placard

---

### SPECIAL HAZARD SYMBOLS

<b>Acid</b>	<b>Acids</b>
<b>Base</b>	<b>Alkalyes, cyanides</b>
<b>Oxy</b>	<b>Oxidizers</b>
<b>Flam</b>	<b>Flammables</b>
<b>Rad</b>	<b>Radioactive</b>
<b>W</b>	<b>Use no water</b>

---

## FIRE EXTINGUISHER SAFETY

Different types of fires require different types of fire extinguishers. Fire extinguishers are all rated based on the type of fire they can put out. **Class A** fires are combustible materials like wood or paper. **Class B** fires are flammable liquids like gasoline, oil, or organic solvents. **Class C** fires are electrical fires. Many fire extinguishers are rated for multiple uses. **A-B-C** fire extinguishers can be used on any of these three types of fires

Fire extinguisher use has been simplified to an acronym, **P. A. S. S.**

- **P**ull the pin
- **A**im at the base of the fire
- **S**queeze the trigger
- **S**weep the area

## EXCAVATION SAFETY

Proper shoring or sloping of trenches and excavations is a major safety issue for many distribution system operators. New construction usually involves more controlled conditions than emergency repairs. Excavations for emergency repairs almost always involve digging and shoring in saturated soils and flooded trenches. A "competent person" must supervise all excavation operations. A competent person is someone who has extensive training in soil mechanics and shoring operations.

All trenches over 4 feet deep must have ladder from entry and exit. The ladders must extend at least 3 feet above the top of the trench and ladders must not be stationed more than 25 feet apart. Trenches over 5 feet deep must be properly shored or sloped to protect entrants from trench wall collapse and cave-ins. The competent person must determine the proper Maximum Allowable Slope, formerly referred to as Angle of Repose, for the given soils type. Soils are classified as Stable Rock or Type A, B, or C. Stable rock is natural solid mineral material that can be excavated with vertical sides and remain intact while exposed. Type C soils are the least stable and require the shallowest Maximum Allowable Slope. Repair excavations are almost always in wet soils. Soils that are saturated with water are considered to be Type C soils.

### Soil Types and Maximum Allowable Slope

<b>Stable Rock</b>	<b>Vertical 90°</b>
<b>Type A</b>	<b>¾:1 53°</b>
<b>Type B</b>	<b>1:1 45°</b>
<b>Type C</b>	<b>1½:1 34°</b>

Shoring must be installed without worker entry into the excavation. Screw jacks or cross braces must be installed from the top down and removed from the bottom up. This prevents entrants from working in an unprotected area. Jacks and cross braces must be anchored by nailing the foot to the vertical timbers. Hydraulic or pneumatic shoring can be installed without requiring worker entry into the trench. If water is used for hydraulic shoring, antifreeze should be added to prevent freezing in cold weather.

Trench boxes are useful for long trenches where it can be moved along the trench. This saves some of the setup and breakdown time required with shoring. When the excavation is deeper than the trench box, the portion above the box must be sloped based on the soil type. The trench box must extend at least 18 inches above the beginning of the sloped wall. Excavation below the trench box is allowed, but the maximum depth is 24 inches. Ladders must be positioned so that workers can enter and exit without stepping outside the shoring or trench box.

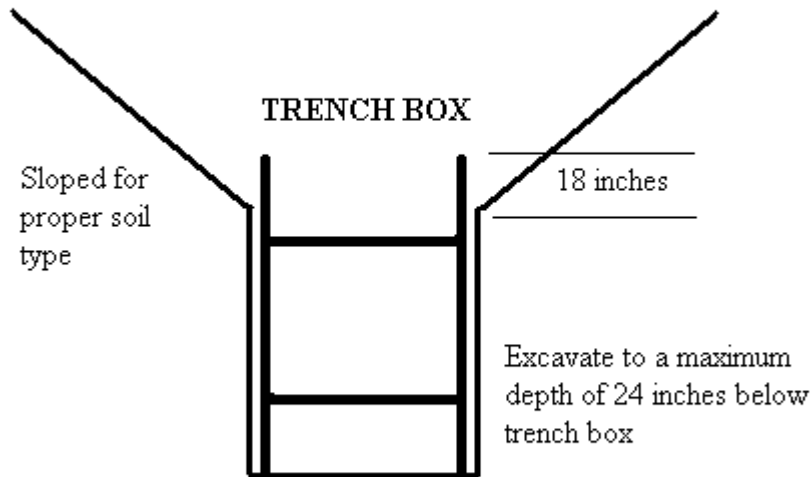

## Trench Box Placement

Excavations may become confined spaces if they are located close to a source of potentially hazardous gases (underground gas tanks, landfills, etc.) Spoil from the excavation must be placed at least 2 feet from the edge of the excavation (farther with more unstable soils.)

**BASIC STUDY QUESTIONS**

1. What does locking out a piece of equipment mean?
2. What must be done prior to entering a confined space?
3. What is the maximum allowable depth of an unshored excavation?

**BASIC SAMPLE TEST QUESTIONS**

1. Ladders must extend at least \_\_\_ feet above the trench?
  - A. 1
  - B. 2
  - C. 3
  - D. 4
2. An attendant must be stationed outside every confined space entry.
  - A. True
  - B. False
3. Each worker must attach a LOTO lock on a locked out machine.
  - A. True
  - B. False

**ADVANCED STUDY QUESTIONS**

1. How many locks must be attached to an energy isolation device?
2. What types of gases are included in confined space atmosphere testing?
3. What are the maximum allowable slopes for Types A, B, and C soils?

**ADVANCED SAMPLE TEST QUESTIONS**

1. Oxygen levels in a confined space must be between \_\_\_\_\_ before the space can be entered.
  - A. 10.5-13%
  - B. 16-18.5%
  - C. 19.5-23.5%
2. The maximum excavation depth below a trench box must not exceed:
  - A. 12 inches
  - B. 18 inches
  - C. 24 inches
  - D. 36 inches
3. Which of the following are potential sources of energy that must be isolated during LOTO procedures?
  - A. Hydraulic energy
  - B. Electrical energy
  - C. Pneumatic energy
  - D. All of the above
4. Ladders must be located no more than \_\_\_ feet from workers.
  - A. 10
  - B. 25
  - C. 35
  - D. 40
5. A standby attendant for a confined space entry must:
  - A. Be in visual and verbal contact with the entrants
  - B. Be able to communicate with emergency responders in case of an accident
  - C. Terminate the entry if problems develop
  - D. All of the above



## Mathematics For Wastewater Operators

The understanding of the mathematics of wastewater treatment is an important tool for all wastewater system operators. This chapter covers most of the major categories of math calculations that are important to know for both certification and daily operations of wastewater systems. The examples range from basic problems like flows, velocities and detention times, that might appear on Grade 1 or 2 exams, to more complex problems that could be found on Grade 3 or 4 exams. The advanced levels will also have more problems related to wastewater treatment process control (F:M, SVI, and MCRT).

### FLOW

The amount of water moving through the system can be measured in one of three different units. They are gpm (gallons per minute), mgd (millions of gallons per day), and cfs (cubic feet per second). The conversions are listed below.

$$\begin{array}{l} \text{mgd} \times 700 = \text{gpm} \qquad \frac{\text{gpm}}{700} = \text{mgd} \\ \text{cfs} \times 449 = \text{gpm} \qquad \frac{\text{gpm}}{449} = \text{cfs} \end{array}$$

Examples:

1. A system averages 2.0 mgd. How many gallons per minute is the daily average?

A. Convert mgd to gpm  
 $2.0 \text{ mgd} \times 700 = \mathbf{1400 \text{ gpm}}$

2. A pipeline has a carrying capacity of 3 cfs. What is the flow in gpm?

A. Convert cfs to gpm  
 $3 \text{ cfs} \times 449 = \mathbf{1347 \text{ gpm}}$

3. A lift station pumps 350 gpm. How many mgd will it pump?

A. Convert gpm to mgd  
 $\frac{350 \text{ gpm}}{700} = \mathbf{0.5 \text{ mgd}}$

### AREAS

In order to calculate volumes of circular tanks and velocities in pipes, the area of the circle must first be determined. There are two basic formulae used to calculate the area of a circle.

$$\begin{array}{l} \text{Area} = 3.1416 \times r^2 \qquad \text{Area} = d^2 \times 0.785 \\ r = \text{radius} \qquad \qquad \qquad d = \text{diameter} \end{array}$$

Examples:

1. A sedimentation basin is 60 feet in diameter. What is the surface area of the tank?

A. Calculate the area  
 $3.1416 \times 30' \times 30' = \mathbf{2830 \text{ square feet}}$   
 $60' \times 60' \times 0.785 = \mathbf{2830 \text{ square feet}}$

2. A pipeline has diameter of 12 inches. What is the area of the pipe?

A. Calculate the area

$$3.1416 \times 6'' \times 6'' = \mathbf{113 \text{ square inches}}$$

$$12'' \times 12'' \times 0.785 = \mathbf{113 \text{ square inches}}$$

## VOLUMES

The volume of a rectangular tank can be determined by multiplying the length, height, and width together.

$$\text{Volume of rectangular tank (ft}^3\text{)} = L' \times H' \times W'$$

Example:

1. A sedimentation basin is 60' long by 40' wide and 10' deep. What is the volume of the tank in cubic feet?

A. Calculate the volume

$$60' \times 40' \times 10' = \mathbf{24,000 \text{ cubic feet (ft}^3\text{)}}$$

The volume of a circular tank can be determined by multiplying the area of the by the height (or depth) of the tank.

$$\text{Volume of circular tank (ft}^3\text{)} = 3.1416 \times r^2 \times H'$$

Or

$$\text{Volume of circular tank (ft}^3\text{)} = d^2 \times 0.785 \times H'$$

Example:

1. A sedimentation basin is 60'in diameter and 12' deep. What is the volume of the tank?

A. Calculate the volume

$$3.1416 \times 30' \times 30' \times 12' = \mathbf{33,900 \text{ cubic feet (ft}^3\text{)}}$$

$$\text{or } 60' \times 60' \times 0.785 \times 12' = \mathbf{33,900 \text{ cubic feet (ft}^3\text{)}}$$

## VOLUMES IN GALLONS

It is often necessary to calculate a volume of a tank or pipe in gallons rather than cubic feet. In most cases the volume must be calculated in cubic feet and then converted into gallons. This is determined by multiplying cubic feet by 7.48.

$$\text{Cubic feet} \times 7.48 = \text{gallons}$$

Example:

1. A sedimentation basin is 60' long by 40' wide and 10' deep. What is the volume of the tank in cubic feet?

A. Calculate the volume

$$60' \times 40' \times 10' = 24,000 \text{ ft}^3$$

B. Convert cubic feet to gallons

$$24,000 \text{ ft}^3 \times 7.48 = \mathbf{179,500 \text{ gallons}}$$

2. A circular tank has a diameter of 40 feet and is 10 feet deep. How many gallons will it hold?

A. Calculate the volume

$$3.1416 \times 20' \times 20' \times 10' = 12,600 \text{ ft}^3$$

B. Convert cubic feet to gallons

$$12,600 \text{ ft}^3 \times 7.48 = \mathbf{94,200 \text{ gallons}}$$

## DETENTION TIME

Detention time is the length of time in minutes or hours for one gallon of water to pass through a tank. To calculate detention time, the capacity of a tank in gallons is divided by the flow in gallons per minute (gpm) or gallons per day (gpd). If gpm is used, the answer will be in minutes and must be divided by 60 minutes to get hours. If gpd is used, the answer will be in days and must be multiplied by 24 hours. The detention time formula can also be used to calculate how long it will take to fill a tank.

Examples:

1. A 50,000 gallon tank receives 250,000 gpd flow. What is the detention time in hours?

A. Find detention time in days

$$\frac{50,000 \text{ gal.}}{250,000 \text{ gal/day}} = 0.2 \text{ days}$$

B. Change days to hours

$$0.2 \text{ days} \times 24 \text{ hrs/day} = \mathbf{4.8 \text{ hours}}$$

2. A tank is 60' x 80' x 10' and the flow is 2.0 mgd? What is the detention time in hours?

A. Find Volume in cubic feet

$$60' \times 80' \times 10' = 48,000 \text{ cu.ft.}$$

B. Change cubic feet to gallons

$$48,000 \text{ cu.ft.} \times 7.48 \text{ gal/cu.ft.} = 359,000 \text{ gal.}$$

C. Change mgd to gal/day

$$2.0 \text{ mgd} = 2,000,000 \text{ gal/day}$$

D. Find D.T. in days

$$\frac{359,000 \text{ gal.}}{2,000,000 \text{ gal/day}} = 0.18 \text{ days}$$

E. Change days to hours

$$0.18 \text{ days} \times 24 \text{ hrs/day} = \mathbf{4.3 \text{ hours}}$$

3. A tank is 100' in diameter and 12 feet deep. If the flow into the tank is 2500 gpm, how many hours will it take to fill the tank?

A. Calculate the volume in cubic feet

$$3.1416 \times 50' \times 50' \times 22' = 94,300 \text{ ft}^3$$

or  $100' \times 100' \times 0.785 \times 22' = 94,300 \text{ ft}^3$

B. Change cubic feet to gallons

$$94,300 \text{ ft}^3 \times 7.48 = 705,000 \text{ gallons}$$

C. Calculate how long until full (detention time)

$$\frac{705,000 \text{ gal}}{2500 \text{ gpm}} = 282 \text{ minutes}$$

$$2500 \text{ gpm}$$

E. Change minutes to hours

$$\frac{282 \text{ min}}{60 \text{ min/hr}} = \mathbf{4.7 \text{ hours}}$$

$$60 \text{ min/hr}$$

## DOSAGE

Chemical dosages are measured in ppm (parts per million) or mg/L (milligrams per liter.) Parts per million (ppm) is always a comparison of weight (pounds per million pounds). One pound of chemical added to one million pounds of water would be a dosage of 1 ppm. Since each gallon of water weighs 8.34 pounds, one million gallons of water weighs 8.34 million pounds and would require 8.34 pounds of chemical to obtain a dosage of 1 ppm. A milligram per liter (mg/L) is the metric term for a dosage equal to ppm.

$$1 \text{ gallon} = 8.34 \text{ lbs.}$$

$$1 \text{ ppm} = 1 \text{ mg/L}$$

The number of pounds of chemical needed to achieve a certain dosage can be determined by multiplying the ppm by the number of millions of gallons treated and then by 8.34 lbs/gal. The amount of water to be treated must always be in terms of millions of gallons (mgd).

$$\text{mg/L} \times \text{mgd} \times 8.34 = \text{pounds per day}$$

Examples:

1. How many lbs/day of chlorine are needed to provide a dosage of 2.2 mg/L in 800,000 gal/day?

A. Change gal/day to mgd

$$800,000 \text{ gpd} = 0.8 \text{ mgd}$$

B. Calculate lbs/day

$$2.2 \text{ mg/L} \times 0.8 \text{ mgd} \times 8.34 = \mathbf{14.7 \text{ lbs/day}}$$

If HTH is used, instead of chlorine gas, only 65-70% of each pound will be chlorine. Therefore, the amount of HTH must be calculated by dividing the pounds of chlorine needed by 0.65 or 0.70.

2. A tank is 44' in diameter and 22' high and is dosed with 50 ppm of chlorine. How many pound of 70% HTH is needed?

- A. Find the volume of the tank in cubic feet  
 $22' \times 22' \times 3.1416 \times 22' = 33,450 \text{ cu.ft.}$
- B. Change cu.ft. to gallons  
 $33,450 \times 7.48 = 250,000 \text{ gallons}$
- C. Change gallons to mgd  
 $250,000 \text{ gallons} = 0.250 \text{ mgd}$
- D. Find lbs of chlorine  
 $50 \text{ ppm} \times 0.25 \text{ mg} \times 8.34 = 104.25 \text{ lbs of chlorine}$
- E. Change percent available to a decimal equivalent  
 $70\% = 0.70$
- F. Find lbs of HTH  

$$\frac{104.25 \text{ lbs Cl}}{0.70} = \mathbf{149 \text{ lbs of HTH}}$$

## VELOCITIES

The flow in a channel can be determined if the velocity and channel dimensions are known. The area of the channel flow is multiplied by the velocity (fps) determine the flow in cubic feet per second (cfs).

Examples:

1. A channel 4 feet wide has water flowing 2 feet deep. The velocity is 5.0 fps. What is the flow in cfs?

- A. Find area of the channel in sq ft  
 $4 \times 2 = 8 \text{ sq.ft.}$
- B. Find the flow in cfs  
 $5.0 \text{ fps} \times 8 \text{ sq.ft.} = \mathbf{40 \text{ cfs}}$

3. A channel 3.2 feet wide has water flowing 18 inches deep. The velocity is 2.8 fps. What is the flow in cfs?

- A. Convert inches to feet  

$$\frac{18}{12} = 1.5 \text{ ft}$$
- B. Find the area of the channel.  
 $3.2 \times 1.5 = 4.8 \text{ sq ft}$
- C. Find the flow in cfs.  
 $2.8 \text{ fps} \times 4.8 \text{ sq ft} = 13.4 \text{ cfs}$

## PROCESS REMOVAL EFFICIENCY

The removal efficiency of a process can be determined by taking the influent strength and subtracting the effluent strength then dividing that number by the influent strength. The decimal value is multiplied by 100 to convert to a percentage.

$$\frac{\text{BOD (in)} - \text{BOD (out)} \times 100}{\text{BOD (in)}} = \text{Percent Removal}$$

Examples:

1. The influent BOD of a trickling filter is 120 mg/L. The effluent BOD is 20 mg/L. What is the removal efficiency for BOD?

A. Find the removal efficiency

$$\frac{120 - 20 \times 100}{120} = \mathbf{83.3\%}$$

2. A primary clarifier has an influent SS of 250 mg/L. The effluent SS is 90 mg/L. What is the SS removal efficiency?

A. Find the removal efficiency

$$\frac{250 - 90 \times 100}{250} = \mathbf{64\%}$$

3. A plant has an influent BOD of 215 mg/L. The plant effluent BOD is 5 mg/L. What is the BOD removal efficiency for the plant?

A. Find the removal efficiency

$$\frac{215 - 5 \times 100}{215} = \mathbf{97.7\%}$$

## PROCESS LOADING CALCULATIONS

The organic loading rates for secondary processes like lagoons and trickling filters can be calculated using the dosage formula to determine the total number of pounds of BOD and dividing it by the unit area or volume (acres for lagoons, 1,000 ft<sup>3</sup> for trickling filters.).

Examples:

1. A 10 acre lagoon receives an average flow of 0.2 mgd and a BOD of 120 mg/L. What is the organic loading in lbs/day /acre?

A. Find the pounds of BOD per day

$$120 \times 0.2 \times 8.34 = 200 \text{ lbs/day}$$

B. Find the pounds per acre

$$\frac{200 \text{ lbs/day}}{10 \text{ acres}} = \mathbf{20 \text{ lbs/day/acre}}$$

2. A trickling filter is 80 feet in diameter and 6 feet deep. The BOD is 60 mg/L and the flow is 0.6 mgd. What is the organic loading rate in lbs per day per 1,000 ft<sup>3</sup>?
- Find pounds of BOD per day  
 $60 \times 0.6 \times 8.34 = 300 \text{ lbs/day}$
  - Find the volume of the filter in cubic feet  
 $40 \times 40 \times 3.1416 \times 6 = 30,200 \text{ cubic feet}$
  - Change cubic feet to thousands of cubic feet  
 $30,200 = 30.2 \text{ thousand cubic feet}$
  - Find the loading rate  

$$\frac{300 \text{ lbs/day}}{30.2} = \mathbf{10 \text{ lbs/day/1000 cubic feet}}$$

## F:M RATIO

The food-to-microorganism ratio is used to determine how much food (BOD) is available for every pound of microorganisms (bugs). To calculate the F:M ratio, divide the pounds of food (BOD loading) by the pounds of bugs under aeration (MLVSS). It requires working two dosage problems and dividing the results.

Examples:

- A 150,000 gallon aeration tank receives an average flow of 1.2 mgd and a BOD of 100 mg/L. The MLVSS is 3000 mg/L. What is the F:M ratio?
  - Find the pounds of BOD per day  
 $100 \times 1.2 \times 8.34 = 1000 \text{ lbs/day}$
  - Find the pounds of MLVSS  
 $3000 \times 0.15 \times 8.34 = 3750 \text{ lbs of MLVSS}$
  - Find F:M ratio  

$$\frac{1000 \text{ lbs/day}}{3750 \text{ lbs MLVSS}} = \mathbf{0.27}$$
- An aeration basin is 40' x 20' x 15' deep. The influent BOD is 80 and the flow is 1.1 mgd. The MLVSS is 2400 mg/L. What is the F:M ratio?
  - Find pounds of BOD per day  
 $80 \times 1.1 \times 8.34 = 734 \text{ lbs/day}$
  - Find the volume of the aeration basin in cubic feet  
 $40 \times 20 \times 15 = 12,000 \text{ cubic feet}$
  - Change cubic feet to gallons  
 $12,000 \times 7.48 = 90,000 \text{ gallons or } 0.09 \text{ mg}$
  - Find the pounds of MLVSS  
 $2400 \times 0.09 \times 8.34 = 1800 \text{ lbs of MLVSS}$
  - Find F:M ratio  

$$\frac{734 \text{ lbs/day}}{1800 \text{ lbs MLVSS}} = \mathbf{0.41}$$

## SLUDGE VOLUME INDEX (SVI)

The sludge volume index uses the settleometer test results to determine the relative density of the settled sludge in milliliters per gram of settled solids. It is determined by multiplying the results from a 1-liter settleometer test in milliliters by 1000 and dividing by the MLSS (mg/L).

$$\frac{\text{Settleometer (ml)} \times 1000}{\text{MLSS (mg/L)}} = \text{SVI}$$

Examples:

1. The settleometer results were 280 ml and the MLSS is 2350 mg/L. What's the SVI?

A. Find the Sludge Volume Index

$$\frac{280 \text{ ml} \times 1000}{2350 \text{ mg/L}} = \mathbf{119 \text{ SVI}}$$

2. The settleometer results were 260 ml and the MLSS is 3000 mg/L. What's the SVI?

A. Find the Sludge Volume Index

$$\frac{260 \text{ ml} \times 1000}{3000 \text{ mg/L}} = \mathbf{87 \text{ SVI}}$$

## MEAN CELL RESIDENCE TIME (MCRT) OR SLUDGE AGE

Mean cell residence time (MCRT), also known as sludge age, is a determination of the average length of time activated sludge stays in the system before it's wasted or it leaves over the effluent weirs. It is determined by calculating the pounds of MLSS in the aeration basin and dividing it by the total pounds of SS that are wasted and in the effluent each day.

$$\frac{\text{Lbs of SS in Aeration}}{\text{Lbs of SS wasted/day} + \text{lbs of SS effluent/day}} = \text{Days MCRT}$$

Examples:

1. An aeration basin is 650,000 gallons and the flow is 2.8 mgd. The MLSS is 2600 mg/L. The WAS flow is 15,000 gpd and WAS SS is 6,000 mg/L. The effluent SS is 8 mg/L. What is the MCRT in days?

A. Find the pounds of MLSS in aeration

$$2600 \text{ mg/L} \times 0.65 \text{ mg} \times 8.34 = 14,100 \text{ lbs}$$

B. Find the pounds of SS in the WAS

$$6,000 \text{ mg/L} \times 0.015 \times 8.34 = 751 \text{ lbs/day}$$

C. Find the pounds of SS in the effluent

$$8 \text{ mg/L} \times 2.8 \text{ mgd} \times 8.34 = 187 \text{ lbs/day}$$

D. Find the MCRT

$$\frac{14,100 \text{ lbs}}{751 + 187} = \frac{14,100}{938} = \mathbf{15 \text{ day MCRT}}$$

2. An aeration basin is 28,000 gallons and the flow is 150,000 gpd. The MLSS is 3400 mg/L. The WAS flow is 2000 gpd and WAS SS is 7,500 mg/L. The effluent SS is 6 mg/L. What is the MCRT in days?
- A. Find the pounds of MLSS in aeration  
 $3400 \text{ mg/L} \times 0.028 \text{ mg} \times 8.34 = 794 \text{ lbs}$
- B. Find the pounds of SS in the WAS  
 $7,500 \text{ mg/L} \times 0.002 \times 8.34 = 125 \text{ lbs/day}$
- C. Find the pounds of SS in the effluent  
 $6 \text{ mg/L} \times 0.15 \text{ mgd} \times 8.34 = 7.5 \text{ lbs/day}$
- D. Find the MCRT  

$$\frac{794 \text{ lbs}}{125 + 7.5} = \frac{749}{132.5} = \mathbf{6 \text{ day MCRT}}$$

## WIRE-TO-WATER CALCULATIONS

The term wire-to-water refers to the conversion of electrical horsepower to water horsepower. The motor takes electrical energy and converts it into mechanical energy. The pump turns mechanical energy into hydraulic energy. The electrical energy is measured as motor horsepower (MHP.) The mechanical energy is measured as brake horsepower (BHP.) And the hydraulic energy is measured as water horsepower (WHP.)

Horsepower is measured by lifting a weight a given distance in a specific time period. One horsepower is the amount of energy required to produce 33,000 ft-lbs of work per minute. That means that lifting 33,000 pounds one foot in one minute or lifting one pound 33,000 feet in the air in one minute would both require one horsepower worth of energy.

When water is pumped, performance is measured in flow (gallons/minute) and pressure (feet of head). If you multiply gallons per minute and feet of head the resulting units would be gallon-feet per minute. Multiply gallon-feet per minute by 8.34 pounds/gallon and the units become foot-pounds (of water) per minute. This can now be converted to water horsepower by dividing by 33,000 ft-lbs/min per horsepower.

$$\frac{\text{Gpm} \times 8.34 \times \text{Feet of Head}}{33,000 \text{ ft-lbs/min/Hp}} = \text{Water Horsepower (WHP)}$$

This equation can be further simplified to:

$$\frac{\text{Gpm} \times \text{Feet of Head}}{3960} = \text{Water Horsepower (WHP)}$$

Brake horsepower is the amount of energy that must go into the pump to produce the required WHP. Losses due to friction and heat in the pump reduce the pump's efficiency and require more energy in than goes out. If a pump is 80% efficient, it requires 10 BHP to generate 8 WHP.

$$\text{BrakeHp} = \frac{\text{WaterHp}}{\text{Pump Efficiency}}$$

Motor horsepower is the amount of electrical energy that must go into the motor to produce the required BHp. Losses due to friction and heat in the motor reduce the motor's efficiency and require more energy in than goes out. If a motor is 88% efficient, it requires 10 BHp to generate 8.8 BHp

$$\text{MotorHp} = \frac{\text{BrakeHp}}{\text{Motor Eff}}$$

OR

$$\text{MotorHp} = \frac{\text{WaterHp}}{\text{Motor Eff} \times \text{Pump Eff}}$$

Motor horsepower can be converted into kilowatts by multiplying by 0.746 Kw/Hp. Kilowatt-hours can be determined by multiplying kilowatts by run time in hours.

$$\text{MotorHp} \times 0.746 \text{ Kw/Hp} \times \text{Hours} = \text{Kw-Hours of electricity}$$

The following example has seven problems that relate to wire-to-water calculations. Each problem will take the calculation one step further. It is intended to show how the steps are linked, not to represent an example of a set of exam questions. An actual exam question would possibly require the calculation of Water horsepower (Problems 1-3) or calculation of cost of operation (Problems 1-7)

Pump Data: 6 Feet - Negative Suction Head  
96 Feet - Discharge Head  
17 Feet - Friction Loss  
400 gpm - Flow  
Motor Efficiency - 90%  
Pump Efficiency - 80%

1. What is the static head on the pump?

$$96 \text{ ft} + 6 \text{ ft} = \mathbf{102 \text{ ft}}$$

2. What is the total dynamic head?

$$96 \text{ ft} + 6 \text{ ft} + 17 \text{ ft} = \mathbf{119 \text{ ft TDH}}$$

3. What is the Water Horsepower that the pump delivers?

$$\frac{400 \text{ gpm} \times 119 \text{ ft}}{3960} = \mathbf{12 \text{ WHp}}$$

4. What is the Brake Horsepower?

A. Change 80% to a decimal

$$80\% = 0.80$$

B. Find Brake Horsepower

$$\frac{12 \text{ Whp}}{0.80 \text{ Pump Eff}} = \mathbf{15 \text{ BHp}}$$

5. What is the Motor Horsepower?

A. Change 90% to a decimal

$$90\% = 0.90$$

B. Find Motor Horsepower

$$\frac{15 \text{ BHp}}{0.90 \text{ Motor Eff}} = \mathbf{16.7 \text{ MHp}}$$

6. How many Kilowatts of electricity does the motor require?

$$16.7 \text{ MHp} \times 0.746 \text{ Kw/HP} = \mathbf{12.5 \text{ Kw}}$$

7. If the pump runs 13 hours a day and electric rates are \$0.09/Kw-Hour, How much does it cost to run the pump for a month (30 days)?

A. Find Kw-Hours per day

$$12.5 \text{ Kw} \times 13 \text{ hours/day} = 162 \text{ Kw-Hours/day}$$

B. Find cost per day

$$162 \text{ Kw-Hours} \times \$0.09/\text{KwHour} = \$14.58/\text{day}$$

C. Find cost for the month

$$14.58/\text{day} \times 30 \text{ days/month} = \mathbf{\$437.40/\text{month}}$$

### BASIC SAMPLE PROBLEMS

- The daily average flow at the plant is 2.8 mgd. What is the average flow in gpm?
  - 1730 gpm
  - 1850 gpm
  - 1960 gpm
  - 2120 gpm
- The flow through a clarifier is 490 gpm. What is the flow in mgd?
  - 0.5 mgd
  - 0.7 mgd
  - 1.2 mgd
  - 1.6 mgd
- A tank is 20' x 60' by 15' deep. What is the volume in gallons?
  - 115,000 gallons
  - 128,000 gallons
  - 135,000 gallons
  - 154,000 gallons
- A tank is 60' in diameter and 22' deep. How many gallons will it hold?
  - 465,000 gallons
  - 528,000 gallons
  - 640,000 gallons
  - 710,000 gallons
- A dosage of 2.4 mg/L of chlorine gas is added to 3.8 mgd. How many pounds per day of chlorine are needed?
  - 68 lbs/day
  - 76 lbs/day
  - 82 lbs/day
  - 88 lbs/day
- The influent BOD is 235 mg/L and the effluent BOD is 10 mg/L. What is the BOD removal efficiency for the plant?
  - 82 %
  - 88 %
  - 90%
  - 96%
- A 17-acre lagoon receives a flow of 220,000 gpd with an influent BOD of 186 mg/L. What is the organic loading rate?
  - 10 lbs/acre/day
  - 12.5 lbs/acre/day
  - 20 lbs/acre/day
  - 32 lbs/acre/day
- A 820,000 gallon clarifier has an influent flow of 6.7 mgd. What is the detention time in hours?
  - 0.8 hours
  - 1.6 hours
  - 2.5 hours
  - 2.9 hours

### ADVANCED SAMPLE PROBLEMS

- The settleometer reading after 30 minutes was 340 ml. The MLSS is 2850 mg/L. What is the SVI?
  - 87
  - 119
  - 136
  - 210

2. A clarifier is 82' in diameter and 12 deep high. The flow is 3600 gpm. What is the detention time in hours?
- 1.8 hours
  - 2.2 hours
  - 2.6 hours
  - 3.1 hours
3. A tank is 120' x 50' x 14' deep. The flow is 2.8 mgd. What is the detention time in hours?
- 3.8 hours
  - 4.4 hours
  - 5.4 hours
  - 6.2 hours
4. A trickling filter is 60 feet in diameter and 7 feet deep. The flow is 0.8 mgd and the BOD in the filter influent is 110 mg/L. What is the organic loading rate in lbs/day/1000 cu.ft?
- 37 lbs/day/1000 cuft
  - 42 lbs/day/1000 cuft
  - 56 lbs/day/1000 cuft
  - 60 lbs/day/1000 cuft
5. The plant flow is 3.6 mgd. The aeration basin influent BOD is 80 mg/L. The basin is 750,000 gallons. The MLVSS is 2350 mg/L. What is the F:M ratio?
- 0.12
  - 0.16
  - 0.23
  - 0.34
6. The plant flow is 1.8 mgd. The MLSS is 4000 mg/L. The aeration basin is 300,000 gallons. The WAS rate is 7,000 gpd and the WAS SS is 8,000 mg/L. The effluent SS is 8 mg/L. What is the MCRT?
- 12 days
  - 17 days
  - 21 days
  - 24 days
7. Pump Data:  
 18 Feet - Positive Suction Head  
 158 Feet - Discharge Head  
 26 Feet - Friction Loss  
 1200 gpm - Flow  
 Motor Efficiency - 86%  
 Pump Efficiency - 78%
- What is the motor horsepower?
- 60 MHP
  - 65 MHP
  - 70 MHP
  - 75 MHP
8. Pump Data:  
 20 Feet - Positive Suction Head  
 185 Feet - Discharge Head  
 18 Feet - Friction Loss  
 300 gpm - Flow  
 Motor Efficiency - 90%  
 Pump Efficiency - 80%  
 Kw-Hour Cost = \$0.11/Kw-Hr  
 Average Run Time – 6  
 Hours/day
- What is the cost to run the pump for 30days?
- \$245.08
  - \$284.34
  - \$410.50
  - \$463.82