

Secondary Treatment

Prepared By: Steve Lujan
Modified By: Lyman Waller



Albuquerque Bernalillo County
Water Utility Authority

What is Secondary Treatment?

Removal of very small suspended solids (colloids) and dissolved solids. The three most common secondary treatment processes are:

1. Trickling Filters
2. Rotating Biological Contractors (RBC's)
3. Activated Sludge



What are colloidal solids?

Colloidal solids are a type of solid found in wastewater.

Colloidal solids are difficult to remove from water. Some can be removed by chemical addition, but it is preferred to use microorganisms, which use the solids as food. During secondary treatment, microorganisms are grown under optimal conditions. They eat the dissolved and colloidal solids and in turn multiply producing more microorganism mass. These microorganisms can be settled from the wastewater and removed. Thus, colloidal solids are removed by converted them into settleable microorganisms that can be removed from the water.



What is BOD?

Biochemical Oxygen Demand is the organic strength of wastewater.

When BOD loading increases, the amount of oxygen that is needed for microorganisms to capture and stabilize the waste will increase. If BOD loading goes down, the demand for oxygen goes down.



Series or Parallel?

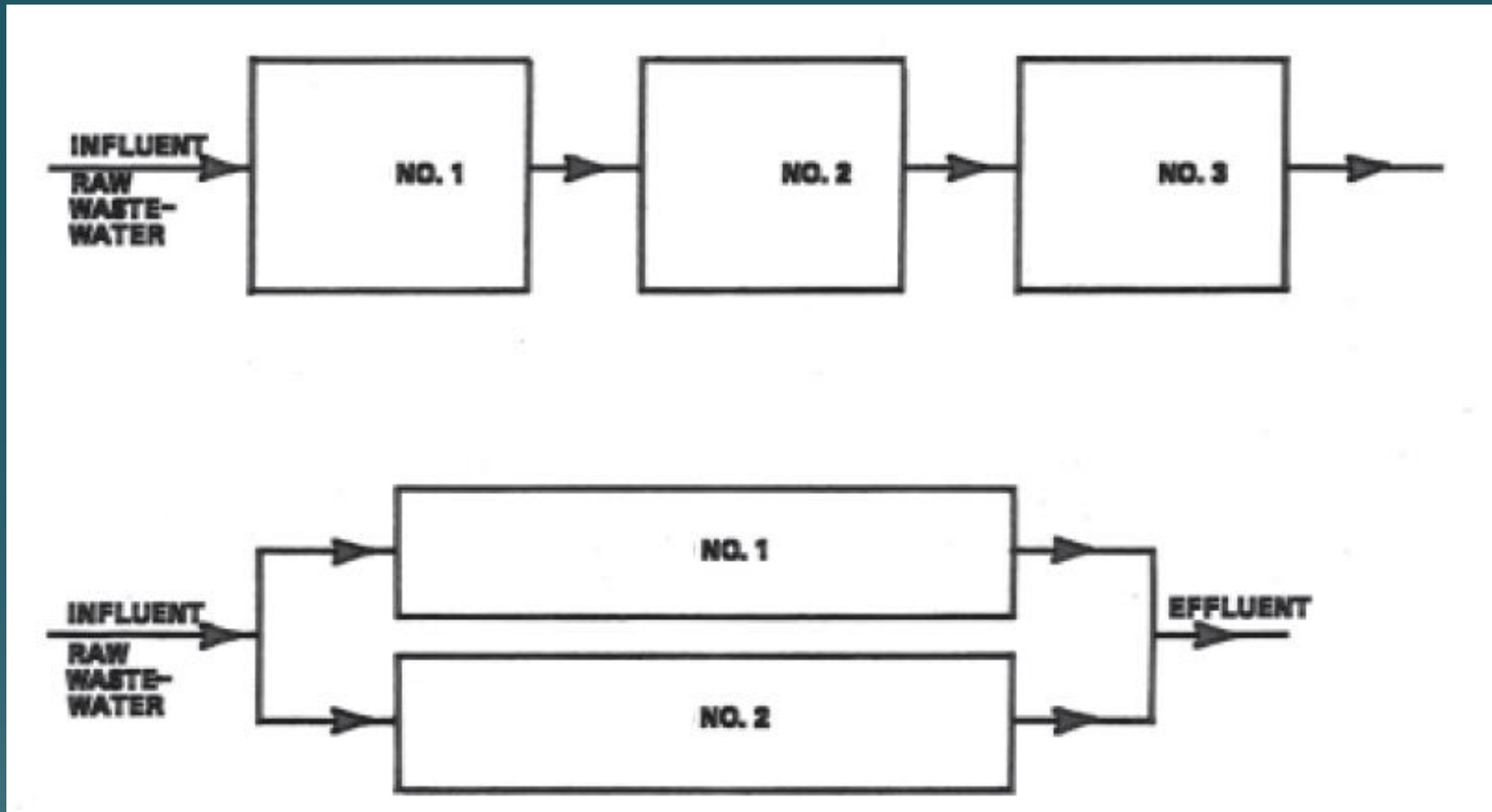

Trickling Filters

Most trickling filters are large diameter, shallow, cylindrical structures filled with stone or plastic media and having an overhead distributor.

The trickling filter is one of the most trouble-free types of secondary treatment.



Trickling Filters consist of three basic parts

1. The media (and retaining structure)
2. The under drain system
3. The distribution system

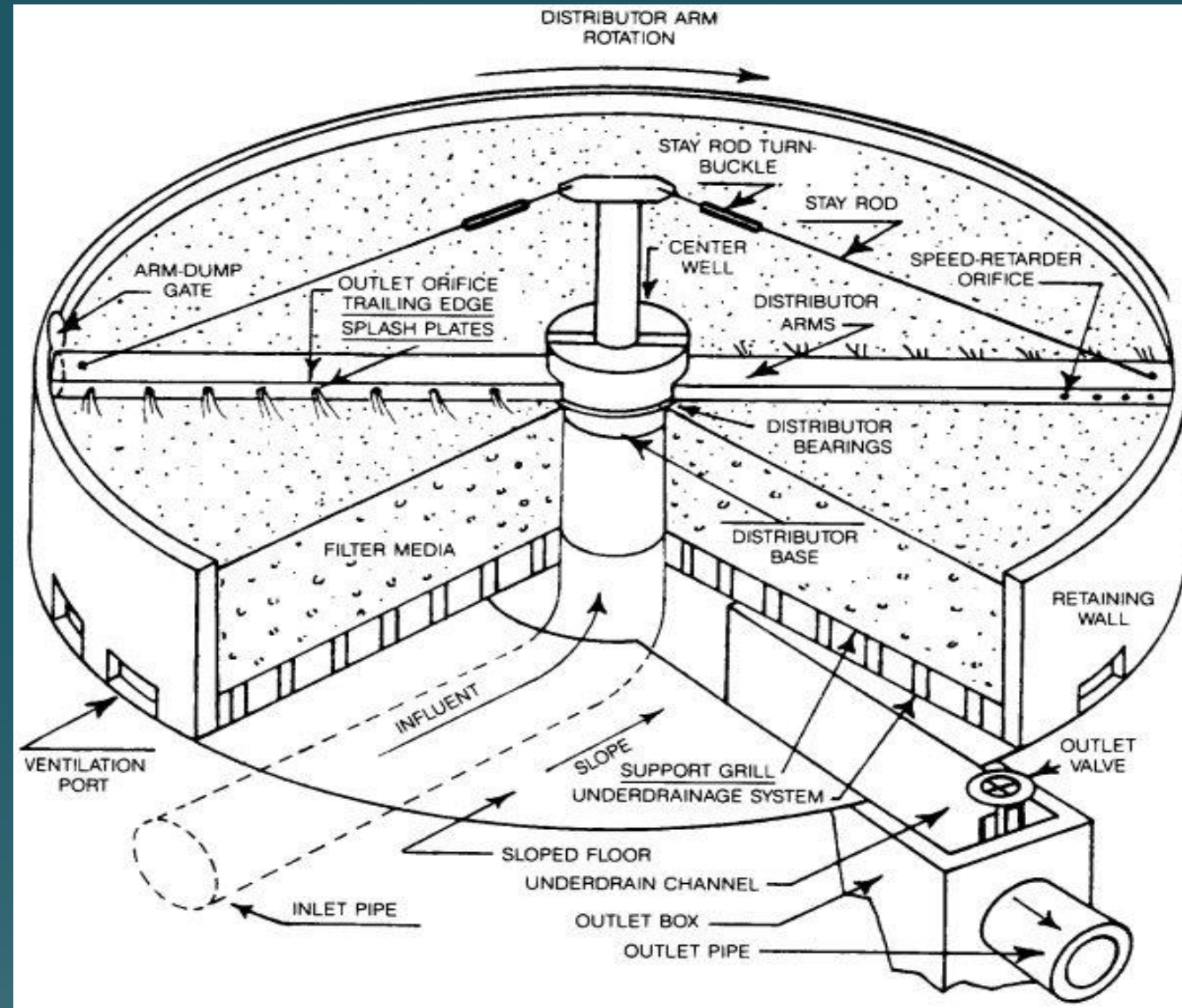

The Media

The media provide a large surface area upon which a biological slime growth develops. This slime growth, called Zooglear Film, contains the living organisms that break down the organic material. The material may be rock, slag, coal, bricks, redwood blocks, molded plastic or any other durable material.



Underdrain System

The underdrain system of a trickling filter has a sloping bottom. This leads to the center channel which collects the filter effluent.

The underdrain system include the use of spaced redwood stringers or prefabricated blocks constructed of concrete, vitrified clay, or other suitable material.

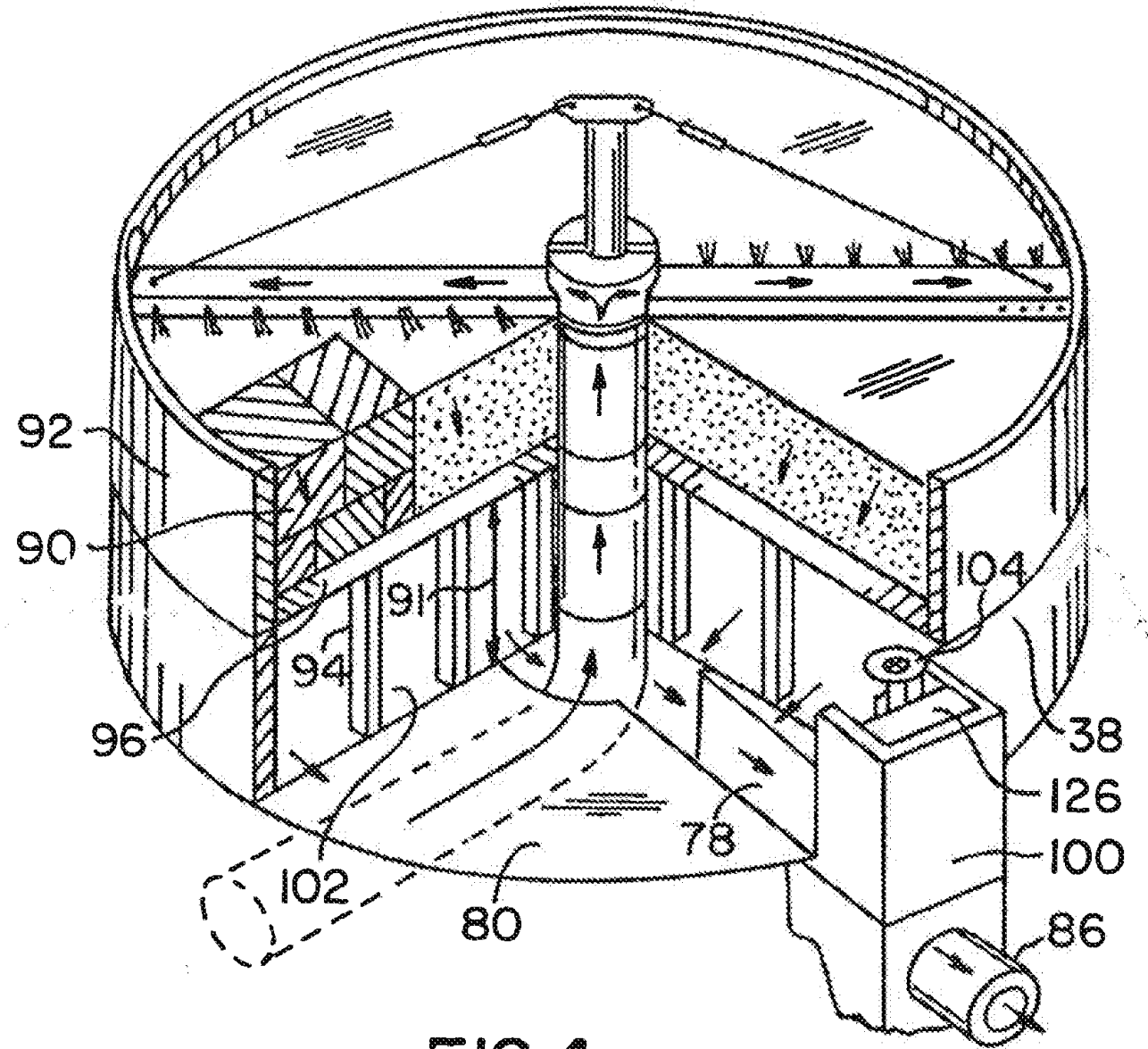

FIG. 4



Distribution System

The distribution system is a rotary-type distributor which consists of two or more horizontal pipes supported a few inches above the filter media by a central column.

The wastewater is generally gravity fed from the column through the horizontal pipes and is distributed over the media through orifices located along one side of each of the pipes (arms). Rotation of the arms is due to the rotating water-sprinkler reaction from wastewater flowing out of the orifices.



Trickling Filter Operation

- The term “filter” can be misleading: Solids are not separated from the liquid by a straining action by the filter.
- Passage of the wastewater through the filter causes the development of a gelatinous coating of bacteria, protozoa, and other organisms on the media. This growth of organisms absorbs and uses much of the suspended colloidal, and dissolved organic matter from the wastewater as it passes over the growth in a thin film.
- Part of this material is used as food for production of new cells, while another portion is oxidized to carbon dioxide and water.



Trickling Filter Operation (cont)

- For the oxidation (decomposition) process to be carried out, the biological film requires a continuous supply of dissolved oxygen which may be absorbed from the air circulating through the filter voids.
- Trickling filters with plastic media may be loaded at much higher rates than rock media without developing plugging, ponding and fly or odor problems.



Classification of Filters

Expressed as gallons per day per square foot of the filter surface area. (GPD/sq ft)

The organic loading is expressed as the pounds of BOD applied per day of 1,000 cubic feet of filter media (lbs BOD/day/1,000 cu ft)



Filter Classifications

- Low-rate
- Intermediate-rate
- High-rate
- Roughing



LOW-RATE FILTERS

- Low-rate filters are commonly used for loadings of less than 25 lb BOD₅ /1000cu ft/day
- The sloughed solids are generally well-digested and as a result these filters yield less solids than higher rate filters.



Intermediate-rate filters

- Can be loaded up to 40 lb BOD₅/1000 cu ft/day.
- In order to ensure good distribution and thorough blending of the filter and secondary effluent, the system should recirculate the trickling filter effluent.
- The biological solids sloughed off are not as well digested as a low-rate filter.



High-rate filters

- Generally loaded at the maximum organic loading capabilities of the filter.
- Loading ranges from 40 to 100 lb BOD₅/1000cu ft/day.
- For good effluent quality, these filters need a second stage process. As a result these filters are often used with combined processes.



Roughing filters

- Roughing filters are designed to allow a significant amount of soluble BOD to bleed through the trickling filter.
- Loading ranges are 100-300 lb BOD₅/1000cu ft/day.



Oxygen Transfer

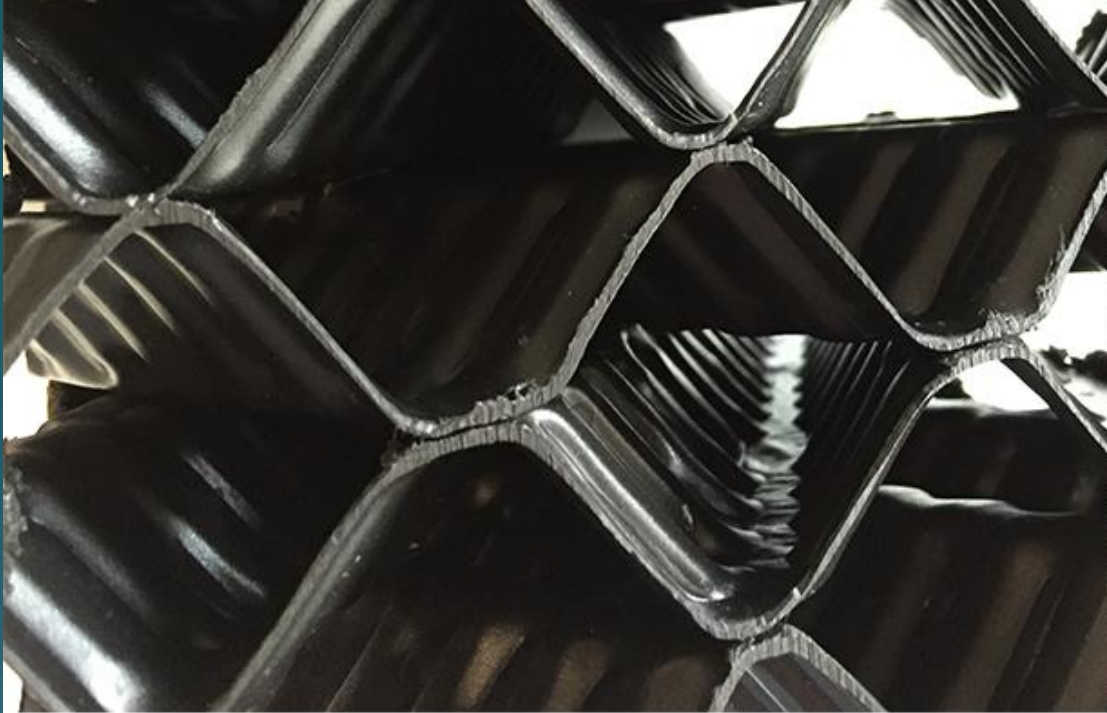

Open structured of plastic media;
efficient oxygen transfer,



stone media; poorer oxygen transfer.



Standard and High Rate Media

Standard: a bed of rocks

High Rate: plastic media or redwood slats



What is recirculation?

Recirculation is a process in which filter effluent is recycled and brought into contact with the biological film more than once.

Recycling of the filter effluent increases the contact time with the biological film and helps to seed the lower portions of the filter with active organisms.

May be constant or intermittent and a steady or fluctuating rate.



Recirculation Pro's

- Keep rotary distributors in motion during low flow periods.
- Prevent drying of the filter growths.
- Prevent freezing.
- Maintain a constant load on the filter and produce better quality of effluent.
- Decrease the opportunity for snail and filter fly (*Psychoda*) breeding
- Increase contact time.
- The strength of the wastewater applied to the filter can be diluted, helping prevent excessive buildup of growth.



Practice Question #1

What adjustment should be made during low flow?



Answer

Increase recirculation rates to maintain flows high enough to keep distributor arm running at the proper speed.



Practice Question #2

What is the BOD loading rate for a high rate trickling filter?



Answer

40-100 pounds per day per 1,000 cubic feet



Practice Question #3

How would you remove fly larvae from a trickling filter?



Answer

Increase recirculation



Practice Question #4

What should you adjust on a trickling filter when you have high storm water influent?



Answer

Run in parallel and decrease recirculation



Practice Question #5

You are operating a trickling filter and your lab analysis reveals high BOD in the effluent of the trickling filter. You increase recirculation. Two days later the BOD levels are the same. Do you increase or decrease recirculation or do nothing at all?



Answer

Make no adjustments, a BOD test takes 5 days to complete.



What have been your
experiences?



Albuquerque Bernalillo County
Water Utility Authority

Rotating Biological Contractors (RBC's)

RBC's are a secondary biological treatment process for domestic and biodegradable industrial wastes.

RBC's have a rotating shaft surrounded by plastic discs called the media.

The shaft and the media are called the drum.

Similar to a trickling filter where biological slime grows on rock or other media and settled wastewater (primary clarifier effluent) is applied to the media.

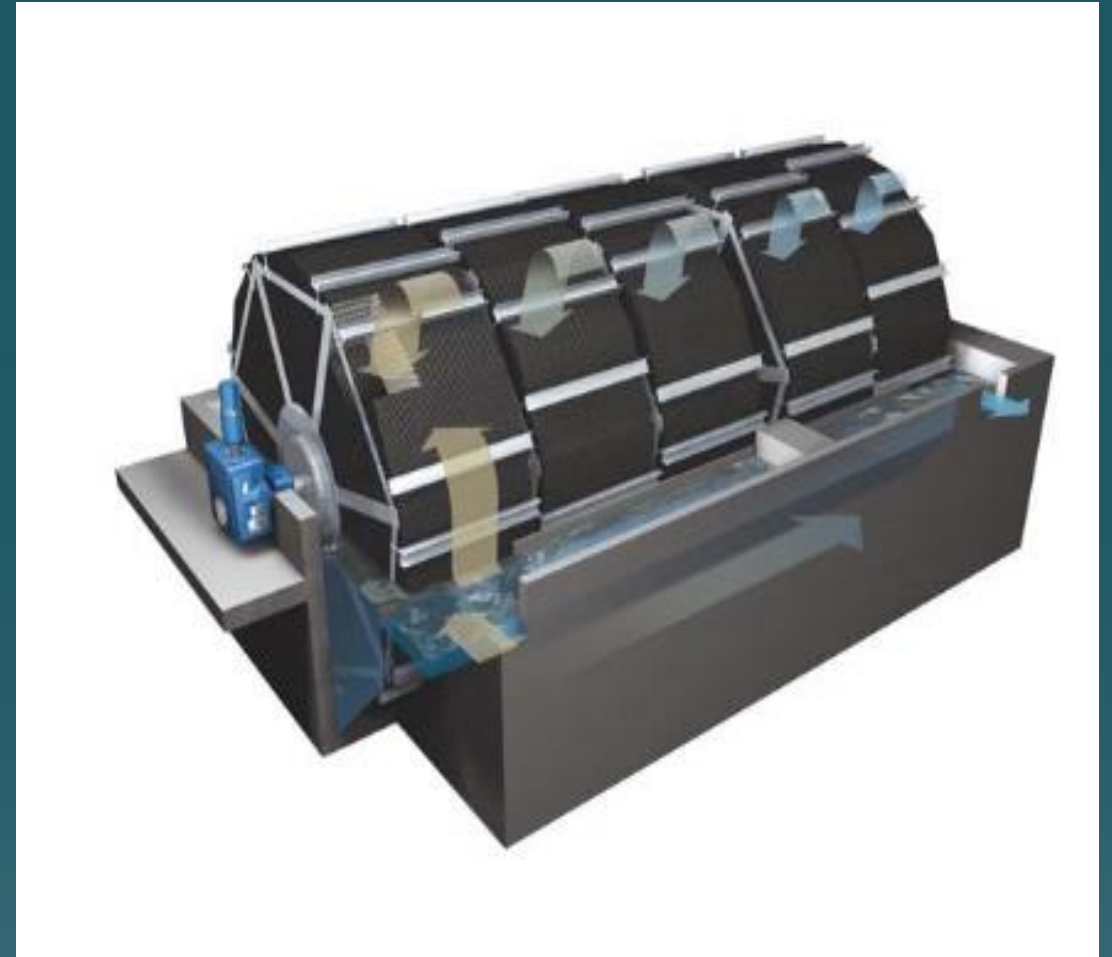

Parts of an RBC

RBC's consist of:

- Concrete or steel tank divided into bays (sections) by baffles
- Orifice or weir located in the baffle
- Rotating media
- Cover over contractor
- Drive assembly
- Influent lines with valves
- Effluent lines with valves
- Underdrains

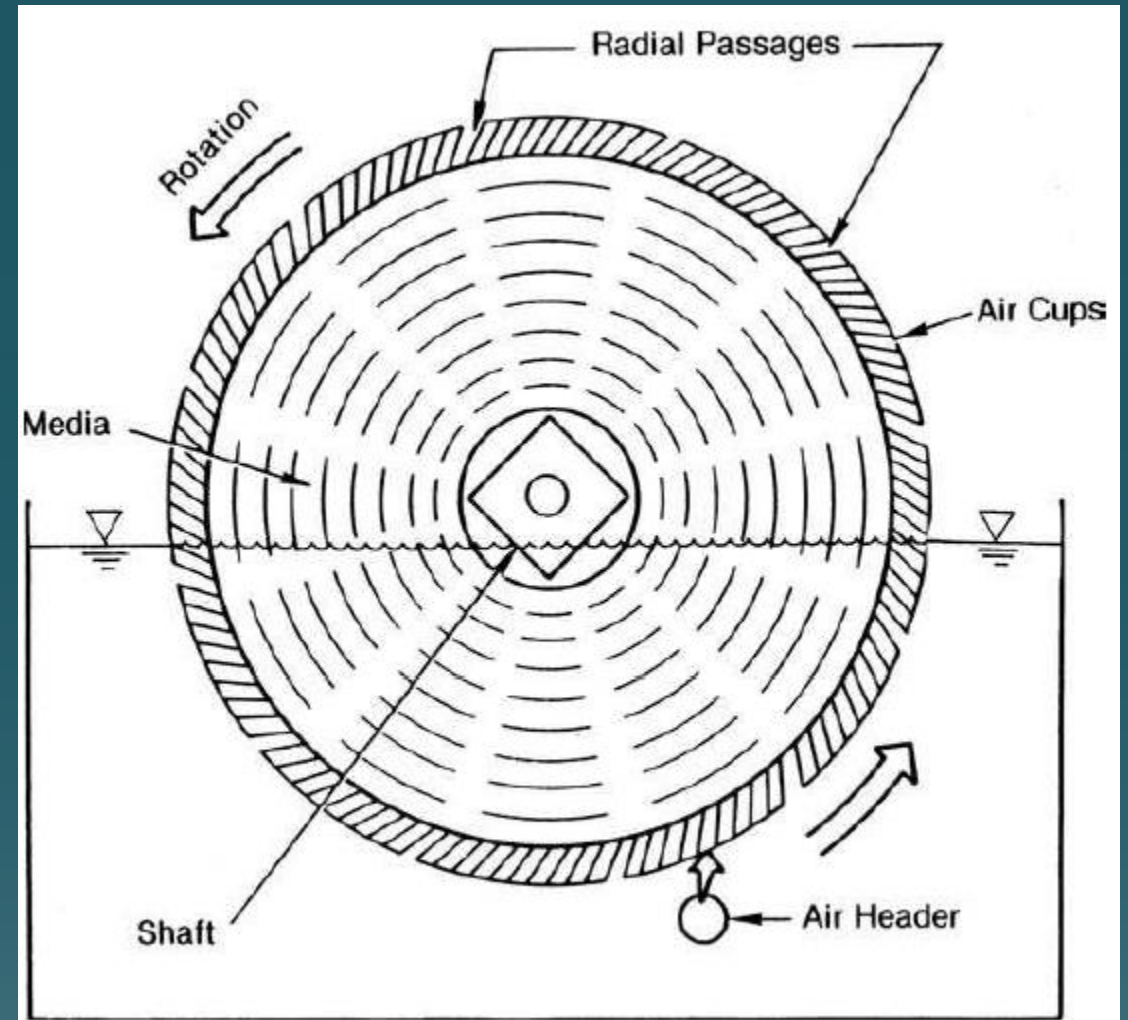

Operation

Biological slime grows on the surface of the plastic disc media. The slime is rotated into the settled wastewater and then into the atmosphere to provide oxygen for the organisms.

RBC's use several plastic media drums. Concrete or coated steel tanks usually hold the wastewater being treated.



Media

The media rotate at approximately 1.5 RPM while approximately 40% of the media surface is immersed in the wastewater.

As the drum rotates, the media picks up a thin layer of wastewater which flows over the biological slimes on the disc. Organisms living in the slime use organic matter from the wastewater for food and dissolved oxygen from the air, thus removing wastes from the wastewater.

An RBC gets D.O. from media rotation.



Covers

RBC's are covered for several reasons:

- Protect biological slime growths from freezing
- Prevent intense rains from washing off some of the slime growth
- Stop exposure of media to direct sunlight to prevent growth of algae
- Avoid exposure of media to sunlight which may cause the media to become brittle
- Provide protection for Operators while maintaining equipment



Practice Question #1

If power is lost for more than 24 hours, how often and how much should you rotate the RBC by hand?



Answer

A quarter turn every 4 hours



Practice Question #2

What percentage of the RBC should be submerged at all times?



Answer

40%



Albuquerque Bernalillo County
Water Utility Authority

Practice Question #3

What type of media would you use on an RBC for high flow applications?



Answer

Plastic media



Albuquerque Bernalillo County
Water Utility Authority

Practice Question #4

Where does grit collect if allowed to enter an RBC drum?



Answer

In the bottom of the drum or beneath the media



Practice Question #5

How does an RBC get D.O.?



Answer

Media rotation



What have been your
experiences?



Albuquerque Bernalillo County
Water Utility Authority

Oxidation Ditches

Oxidation ditches is a modified activated sludge biological treatment process that uses long solids retention times (SRT's) to remove biodegradable organics.

The components of an oxidation ditch are rotors, level control weir and concrete wedge and track.

The track consists of a long channel of an elliptical or circular shape. Though it requires a relatively large area, it is simple and can be easily operated as well as being able to remove nitrogen easily. Widely used in relatively small wastewater treatment plants.

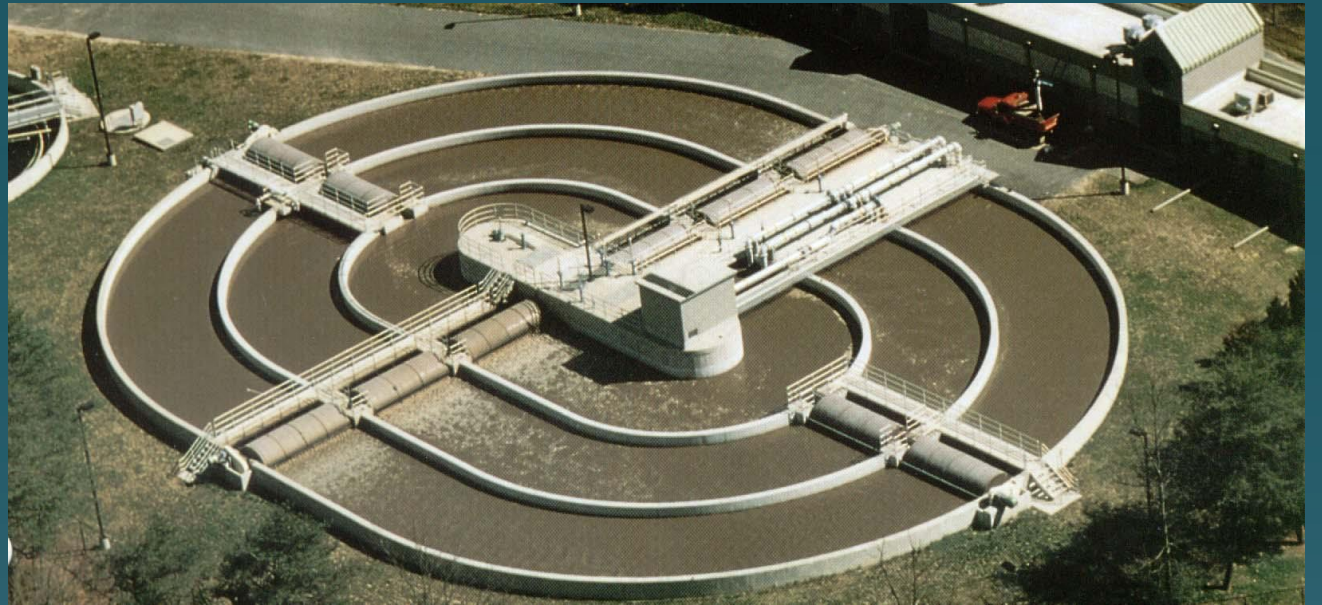

Brush Rotors

Brush rotors can be horizontally or vertically mounted to provide circulation, oxygen transfer, keeps solids suspended and aeration in the ditch.

The velocity and D.O. levels can be adjusted by changing rotor speed and operating depth. The deeper the depth, the more D.O.



Operating Parameters

- Detention time: 3 - 24 hours
- MLSS: 3,000 - 6,000 mg/l
- F:M: 0.03 - 0.1
- Sludge Age: 20 – 35 days
- D.O. Levels: 0.5 – 3.0 mg/l
- Velocity: 1.0 – 1.5 fps (1.0 minimum)
- Liquid levels: 3 – 7 feet



Advantages

1. Easy to maintain
2. D.O is easily controlled by changing rotation of the rotor and depth
3. Requires little energy
4. Performs nitrification and denitrification easily
5. Can be modified to remove Phosphorus



Disadvantages

1. Requires a large area.
2. Effluent suspended solids concentrations are relatively high compared to other activated sludge processes.



Practice Question #1

How often should the components in an oxidation ditch be cleaned?



Answer

Anytime it's drained for service or maintenance (when performing routine cleaning).



Practice Question #2

What do the rotors in an oxidation ditch do?



Answer

Provides D.O. and keeps solids suspended



Practice Question #3

What are the components of an oxidation ditch?



Answer

1. Rotor
2. Level control weir
3. Concrete wedge
4. Track



Practice Question #4

What does white foam in an oxidation ditch mean?



Answer

Sludge wasting rate should be reduced



Practice Question #5

Dark foam on the water surface



Answer

Sludge wasting rate should be increased



What have been your
experiences?



Albuquerque Bernalillo County
Water Utility Authority

Activated Sludge

A suspended growth process that primarily removes dissolved organic solids as well as settleable and non-settleable suspended solids.

The activated sludge itself consists of a concentration of microorganisms and sludge particles that are naturally found in raw or settled wastewater. These organisms are cultivated in aeration tanks, where they are provided with D.O. and food from the wastewater. The term “activated” comes from the fact that the articles are teeming with bacteria, fungi, and protozoa.





Albuquerque Bernalillo County
Water Utility Authority

Diffused Aeration Systems

Diffusers are perforated membrane, porous disc, or other device used for discharging air into the basins.

A diffuser breaks up the air stream from the blowers into fine bubbles in the mixed liquor. The smaller the bubbles, the greater the oxygen transfer, due to the greater surface area of rising air bubbles in the water.

The distribution system consists of numerous diffusers attached to the bottom of air Headers. These diffusers are typically located near the bottom of the aeration tank. This location encourages mixing and discourages settling.



Aeration Blowers

Mechanical blowers supply the aeration for diffused aeration systems. Blowers are typically either the positive displacement (rotary) or centrifugal (turbine) type and provide air to the various plant processes through a pipe or conduit header system.

Air headers are located in or along the aeration tank and are connected to the air distribution system from which they supply air to the diffusers.





Albuquerque Bernalillo County
Water Utility Authority

Nitrification

Nitrification is the process by which ammonia is oxidized into nitrite then nitrate. Working under strict aerobic conditions (> 1.0 mg/L D.O.), two groups of autotrophic microorganisms accomplish nitrification. The species *Nitrosomonas* is primarily responsible for converting ammonia into nitrite, while the species *Nitrobacter* converts nitrite into nitrate. Both organisms are strict aerobes and very sensitive to changes in their environment.



Denitrification

Denitrification is the process by which microorganisms reduce nitrate into nitrogen gas. A number of species that occur in wastewater are capable of accomplishing denitrification. These are sometimes referred to as facultative organisms. All of the organisms that can accomplish denitrification are Heterotrophic, because they can metabolize complex organic substances.



Process Control

- The characteristic of the influent that is going to the aeration basin
- The environment in the aeration basin that must be maintained to ensure good treatment
- The operating conditions within the secondary clarifier, which affects how well solids separation will occur



Influent Characteristics

In most municipal activated sludge wastewater treatment facilities, the influent flow and BOD/TSS concentration does not vary by more than 10% per day. This results in a relatively stable loading being applied to the aeration basin.

However, for some facilities, the flow or the BOD/TSS concentration varies greatly. For example, a process may have high loading for several days a week while local industry (such as a food processing plant) is in operation.

Accurate influent flow measurements are necessary.



Food and Dissolved Oxygen

The aeration basin environment itself can best be described as a zoo of microorganism, each competing for oxygen, food and the ability to reproduce. They must be provided with the correct amount of oxygen, mixing and food. The food is supplied in the form of dissolved and suspended solids in the wastewater itself.

A dissolved oxygen level of >1.0 mg/L is desirable, but it is important to understand that the required level of dissolved oxygen is actually related to the F:M ratio that the system is operating under. This is because the microorganisms in the basin primarily consume the oxygen as they capture and metabolize the dissolved and particulate waste solids.



Adequate Mixing

No settling should occur in the basin. Solids that settle to the bottom of the basin will rapidly become septic and cause a variety of problems, such as increased oxygen demand, lower aeration basin detention times and excess growth of the types of filamentous bacteria that are associated with septic conditions.

Excessive mixing can shear floc particles, leading to increased TSS in secondary clarifiers.



Maintaining the Correct F:M Ratio

The amass of microorganisms must be maintained at the correct level needed to consume virtually all of the food that enters the system each day.

The amount of loading varies a little each day, overall, it stays close to the same. The amount of microorganisms must be controlled in order to meet loading.

The amount of food is determined by calculating BOD loading in terms of pounds per day entering the aeration basin. The mass of microorganisms is calculated based on the mass, in pounds of mixed liquor volatile suspended solids in the aeration basin.



Why MLVSS?

The volatile suspended solids are used in this calculation because it is assumed that all of the volatile solids are comprised of living organisms and the non-volatile solids are inert matter that does not contribute to stabilizing the waste solids.



Ideal F:M

Signs of a system with ideal F:M are a clear, high quality effluent with a small amount of crisp white foam on the surface and the mixed liquor is a chocolate brown color.



High F:M

Cloudy effluent, large floc particles going over secondary clarifier weirs (straggler floc). Lots of frothy white or gray foam, light brown or tan mixed liquor, elevated BOD and TSS.

Common symptoms in an overloaded plant or during start-up conditions.

In this case, a larger mass of MLSS is needed by reducing wasting.



Low F:M

Thick, dark foam on the aeration basin surface, the mixed liquor is dark brown or even a dark reddish color. Floating sludge on the surface of the secondary clarifier and pin floc observed in the effluent flow.



Settleometer Test

The settleometer test is a method of simulating the settling of activated sludge in a secondary clarifier. The test is performed on a sample of mixed liquor taken from the end of the aeration basin, right before it enters the secondary clarifier.

The sample is usually 1-2 liters and is placed into a special settleometer container. The test is conducted by observing and recording the settling of the sludge every five minutes for the first half hour, then 60 minutes and after 120 minutes.

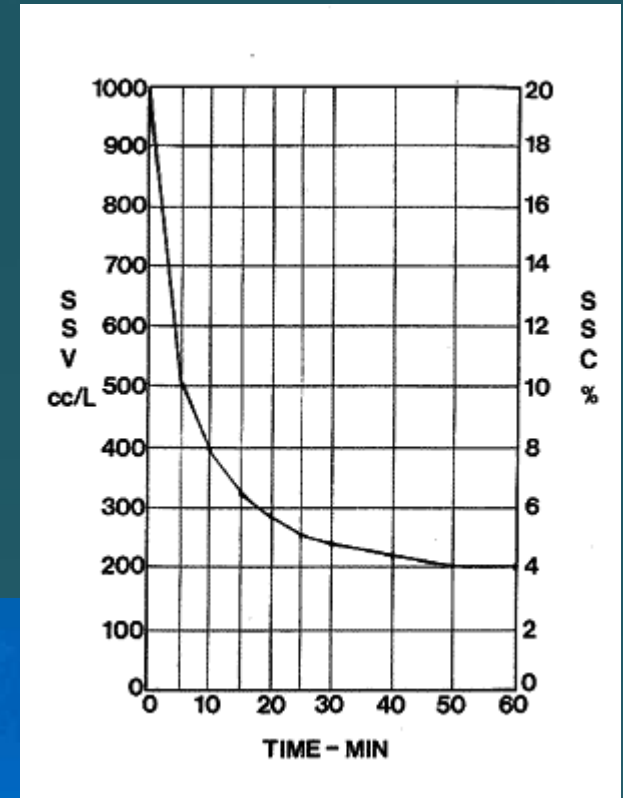
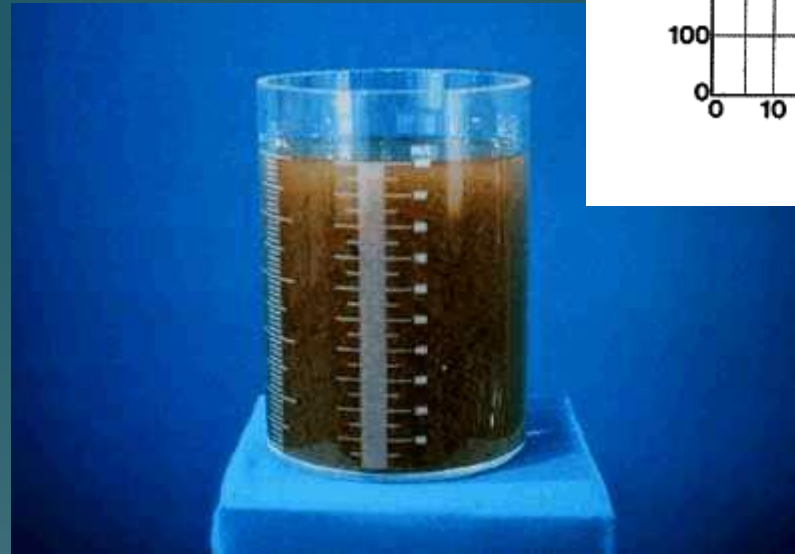

Sludge Volume Index (SVI)

In order to analyze the settling characteristics at a given MLSS concentration, operators calculate the value known as the sludge volume index, or SVI. It is calculated by knowing both sludge settling characteristics and its MLSS concentration

The SVI is most useful at identifying filamentous organism outbreaks, allowing operators to respond before the system is out of control. For most activated sludge treatment plants, a SVI range of 80 – 120 mL/g signals good treatment.





Solids Retention Time

Solids Retention Time is the average time the activated sludge solids are in the system. The SRT is an important design and operating parameter for the activated sludge process and is usually expressed in days. (what is coming into the system each day)



Mean Cell Residence Time (MCRT)

A system's MCRT is a representation of the average time (in days) that the bacterial cell will remain in the system before being removed as WAS or leaving in the effluent. The calculation is made by dividing the total pounds of MLSS in the aeration basin by the total pounds wasted each day and the total pounds that exit in the effluent each day.



Types of Activated Sludge Treatment Processes

1. Conventional Activated Sludge
2. Extended Aeration Activated Sludge
3. Contact Stabilization Activated Sludge



Conventional Activated Sludge

Detention time: 4 – 8 hours

MLSS: 1,000 – 4,000 mg/L

System SRT: 3.5 – 10 days

System F:M Ratio: 0.25 – 0.5 : 1

RAS pumping rate: 15 - 75% (of plant influent flow)



Extended Activated Sludge

Detention time: 12 - 24 hours

MLSS: 2,000 – 5,000 mg/L

System SRT: 10 days

System F:M Ratio: 0.05 – 0.15:1

RAS pumping rate: 50 - 150% (of plant influent flow)



Contact Stabilization Activated Sludge

Detention time in the contact tank: 0.3 - 3 hours

Detention time in the stabilization tank: 4 – 8 hours

MLSS in the contact tank: 1,000 – 3,000 mg/L

MLSS in the stabilization tank: 2 – 6 times the concentration in the contact tank

System SRT: < 3.5 days

System F:M Ratio: 0.5 - > 1.0 : 1



Microorganisms

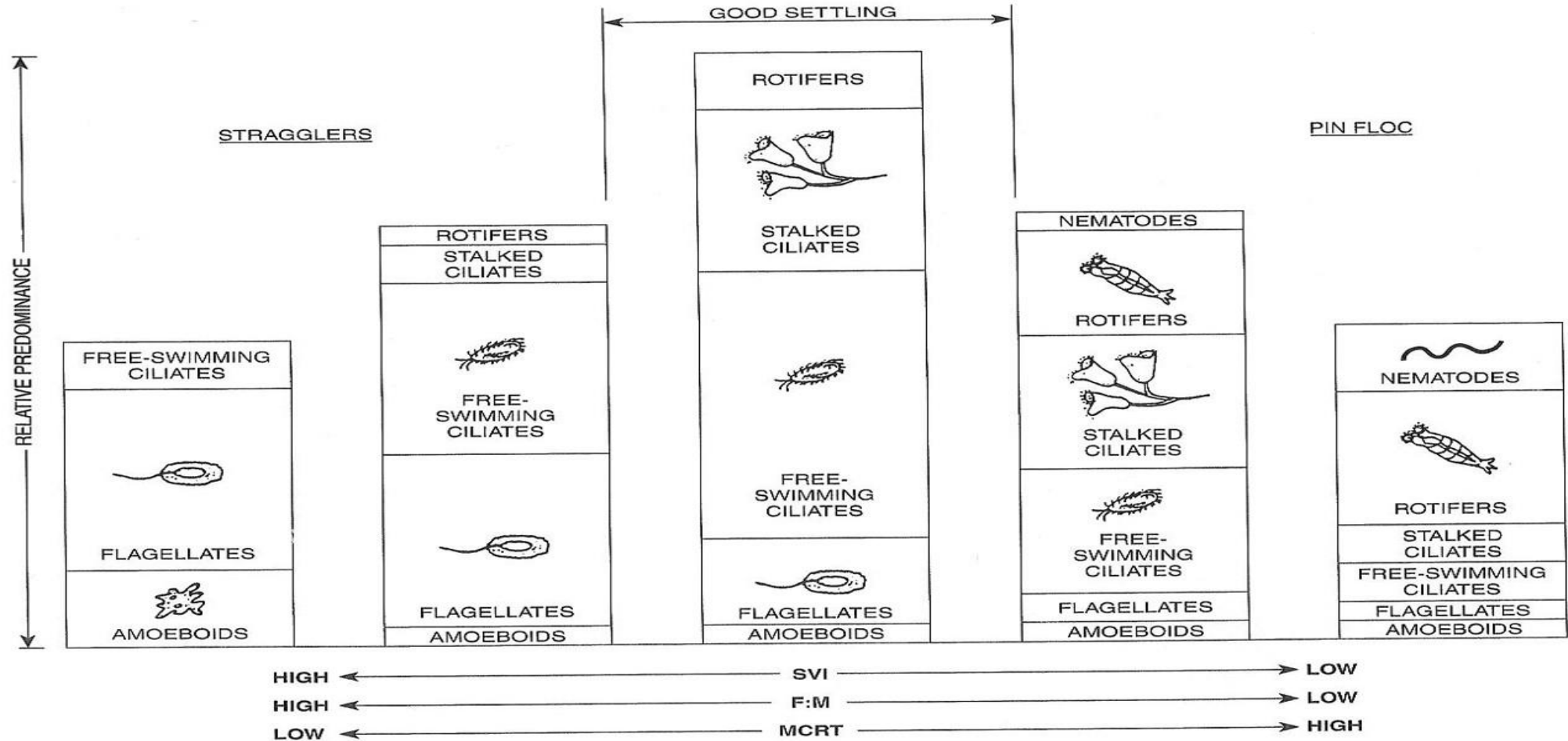

Fig. 11.49 Population predominance versus operational guidelines (Bar graph taken from EPA PROCESS CONTROL MANUAL FOR AEROBIC BIOLOGICAL WASTEWATER TREATMENT FACILITIES, 1977)



Albuquerque Bernalillo County
Water Utility Authority



Practice Question #1

What is SVI?



Answer

Sludge Volume Index



Practice Question #2

How is SVI calculated?



Answer

By knowing both sludge settling characteristics
and its MLSS concentration



Practice Question #3

How is an SVI value expressed?



Answer

In mL/g



Albuquerque Bernalillo County
Water Utility Authority

Practice Question #4

What color of sludge is a sign of healthy sludge in an activated sludge process?



Answer

Medium (chocolate) brown



Practice Question #5

Which odor is acceptable for an activated sludge process?



Answer

Earthy smell

(from Nitrogen gas being expelled into the atmosphere)



What have been your
experiences?



Albuquerque Bernalillo County
Water Utility Authority